

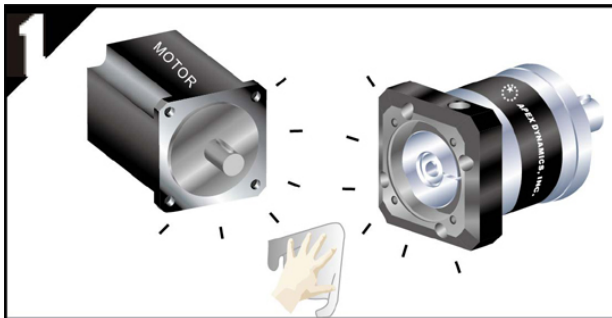

MOTOR MOUNTING INSTRUCTION

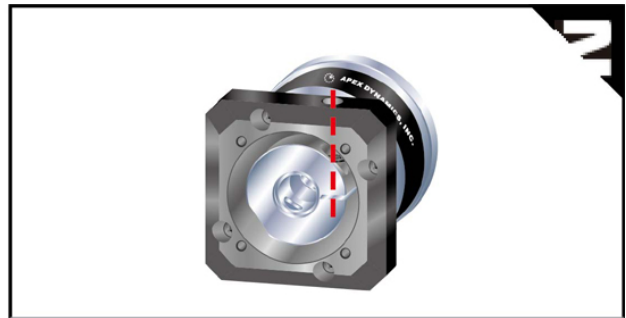

Double-check the motor and gearbox size
Clean the mounting surface



Rotate the set collar until the bolt is aligned with access hole.

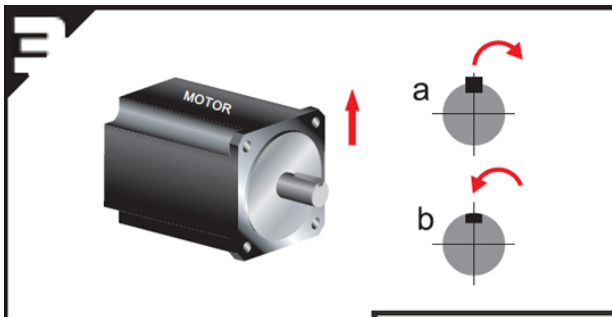

a Remove motor key, if necessary
b Insert balance key, if necessary

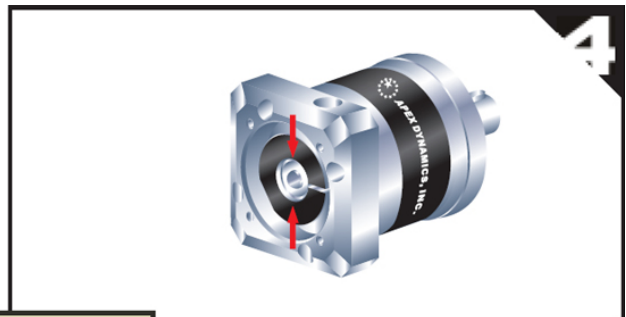

Check motor shaft size and insert bushing, if necessary

Correct Installation

When installing on keyed or flatted shafts, orient per figures below.

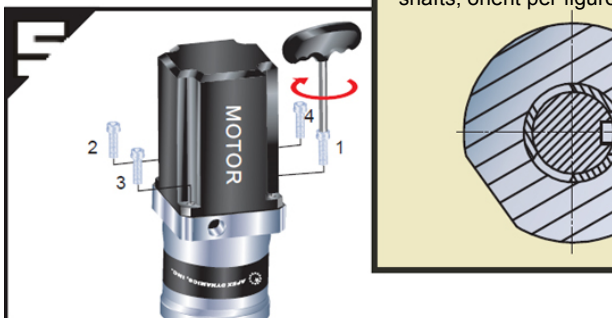

Set at vertical position, tighten the mounting bolts (including washer) in 1~4 order with wrench to 5% specified torque (see table 1)



Tighten the set collar bolt with torque wrench to specified torque (see table 2)



Tighten the mounting bolts in 1~4 order with torque wrench to specified torque (see table 1)



Insert the plug



MOTOR MOUNTING INSTRUCTION

Table 1 Tightening torque recommended for motor mounting bolt

Bolt size	Width Across Flats	Strength 8.8 Tightening Torque		Strength 10.9 Tightening Torque		Strength 12.9 Tightening Torque	
	[mm]	[Nm]	[In-lbs]	[Nm]	[In-lbs]	[Nm]	[In-lbs]
M3 x 0.5P	2.5	1.3	12	1.8	16	2.1	19
M4 x 0.7P	3	3	27	4.1	37	4.9	44
M5 x 0.8P	4	6.1	55	8.2	73	9.8	87
M6 x 1P	5	11	98	14	124	17	151
M8 x 1.25P	6	25	222	34	302	41	364
M10 x 1.5P	8	49	434	67	594	80	709
M12 x 1.75P	10	85	753	116	1028	139	1232
M14 x 2P	12	137	1214	186	1648	223	1976
M16 x 2P	14	210	1860	286	2534	343	3038

Table 2 Tightening torque recommended for set collar bolt

Gearbox size	Motor shaft diameter	Bolt Size	Width across flats	Tightening torque		
	[mm]	[mm]	[mm]	[Nm]	[In-lbs]	
PEII 050 PGII 040 PSII A	PAII 042 PDII 053	C3 ≤ 8	M5 x 0.8P x 16L	4	9,8	87
		C3 ≤ 11	M5 x 0.8P x 16L	4	9,8	87
		C3 ≤ 14	M5 x 0.8P x 16L	4	9,8	87
PEII 070 PGII 060 PSII B	PAII 060 PDII 064 PLII 070	C3 ≤ 8	M5 x 0.8P x 16L	4	9,8	87
		C3 ≤ 11	M5 x 0.8P x 16L	4	9,8	87
		C3 ≤ 14	M5 x 0.8P x 16L	4	9,8	87
		C3 ≤ 19	M8 x 1.25P x 25L	6	41	364
PEII 090 PGII 080 PSII C	PAII 090 PDII 090 PLII 090	C3 ≤ 14	M5 x 0.8P x 16L	4	9,8	87
		C3 ≤ 19	M8 x 1.25P x 25L	6	41	364
		C3 ≤ 24	M8 x 1.25P x 25L	6	41	364
		C3 ≤ 28	M8 x 1.25P x 25L	6	41	364
PEII 120 PGII 120 PSII D	PAII 115 PDII 110 PLII 120	C3 ≤ 19	M8 x 1.25P x 25L	6	41	364
		C3 ≤ 24	M8 x 1.25P x 25L	6	41	364
		C3 ≤ 28	M8 x 1.25P x 25L	6	41	364
		C3 ≤ 32	M10 x 1.5P x 30L	8	80	709
		C3 ≤ 35	M10 x 1.5P x 30L	8	80	709
		C3 ≤ 38	M10 x 1.5P x 30L	8	80	709
PEII 155 PGII 160 PSII E	PAII 142	C3 ≤ 19	M8 x 1.25P x 25L	6	41	364
		C3 ≤ 24	M8 x 1.25P x 25L	6	41	364
		C3 ≤ 28	M8 x 1.25P x 25L	6	41	364
		C3 ≤ 32	M10 x 1.5P x 30L	8	80	709
		C3 ≤ 35	M10 x 1.5P x 30L	8	80	709
		C3 ≤ 38	M10 x 1.5P x 30L	8	80	709
		C3 ≤ 42	M12 x 1.75P x 35L	10	139	1232

Note: Tightening torque values can be exceeded by 20% for increased clamping force.

Apex Dynamics bv
 Churchillaan 101
 NL-5705 BK Helmond
 The Netherlands

Tel. : +31 (0)492 509 995
 Fax : +31 (0)492 509 997
 E-mail : sales@apexdyna.nl

For more information, please visit our website: www.apexdyna.nl

High Precision Planetary Gearboxes