

AT-L series

Overview

- Spiral bevel gearbox with one input and two output shaft.
- Stainless steel housing
- Stainless steel input and 2 output shafts with or without key
- Nominal torques:
 - T_{2N} : 12 Nm – 3.200 Nm
- Ratios
 - 1-stage : 1 / 1,5 / 2 / 3 / 4 / 5
- Low backlash
 - 1-stage : ≤ 6 arcmin
- high efficiency
 - 1-stage: $\geq 98\%$
- Easy mount
- Low Noise
- Compact structure
- Sizes available: AT065L / AT075L / AT090L / AT110L / AT140L / AT170L / AT210L / AT240L / AT280L

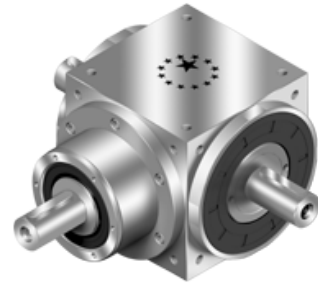

Specifications

Model No.	Trap	Ratio ¹	AT065	LAT075	LAT090	LAT110	LAT140	LAT170	LAT210	LAT240	LAT280L	
Nominal Output Torque T_{2N}	Nm	1	1	25	45	78	150	360	585	1,300	2,150	3,200
			1.5	25	45	78	150	360	585	1,300	2,150	3,200
			2	24	42	68	150	330	544	1,220	2,010	3,050
			3	18	33	54	120	270	450	1,020	1,650	2,850
			4	13	28	48	100	224	376	860	1,410	2,300
			5	12	25	40	85	196	320	740	1,210	2,000
Max Acceleration Torque T_{2B}	Nm	1	1~5	1.5 keer Nominaal koppel T_{2N}								
Max. Acceleration Input Speed n_{1B}	rpm	1	1~5	7,500	6,500	5,500	4,500	3,500	3,000	2,200	2,000	1,700
Backlash*	arcmin	1	1~5	≤ 6	≤ 6	≤ 6	≤ 6	≤ 6	≤ 6	≤ 6	≤ 6	≤ 6
Max. Radial Load F_{1rB} Input d1	N	1	1~5	700	950	1,450	2,100	2,700	3,800	7,800	9,600	10,500
Max. Radial Load F_{2rB} Output d2	N	1	1~5	900	1,100	1,700	2,700	4,800	6,600	11,500	16,000	18,000
Max. Axial Load F_{1aB} Input d1	N	1	1~5	350	425	725	1,050	1,350	1,900	3,900	4,800	5,250
Max. Axial Load F_{2aB} Output d2	N	1	1~5	450	550	850	1,350	2,400	3,300	5,750	8,500	9,000
Service Life	hr	1	1~5	20,000*								
Efficiency η	%	1	1~5	≥ 98 %								
Weight	kg	1	1~5	2.6	4.2	6.8	11.6	19.8	34.8	66.2	98.1	155.7
Operating Temp	°C	1	1~5	-10°C~+90°C								
Lubrication		1	1~5	synthetisch smeermiddel, ISO VG 150								
Noise Level ($n_1=1500$ rpm, No Load)	dB(A)	1	1~5	≤68	≤70	≤74	≤76	≤77	≤78	≤80	≤82	≤83

1. Ratio ($i=N$ in / N out)

2. Apply to the input shaft center @ 100 rpm

3. Apply to the output shaft center @ 100 rpm

* S1 service life 10,000 hrs

* Backlash is measured at 2% Nominal Output Torque T_{2N}

Rotation Direction

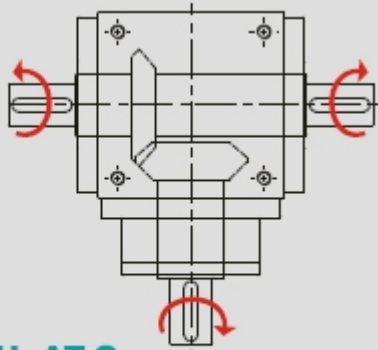

AT-L AT-H AT-C
AT-FL AT-FH AT-FC

Inertia

Model No.	Stage	Ratio ¹	AT065L	AT075L	AT090L	AT110L	AT140L	AT170L	AT210L	AT240L	AT280L
Mass moments of inertia J ₁ kg*cm ²	1	1	0.51	1.30	3.16	7.70	23.57	58.99	195.40	369.34	799.12
		1.5	0.64	1.16	2.82	6.74	19.37	49.28	155.45	283.58	595.78
		2	0.44	1.11	2.70	6.31	17.75	45.35	140.24	249.74	511.76
		3	0.43	1.09	2.66	6.17	17.18	44.01	134.95	237.71	483.06
		4	0.43	1.09	2.65	6.13	17.06	43.70	133.58	234.72	476.26
		5	0.43	1.09	2.65	6.12	17.02	43.60	133.14	233.67	473.58

Sizes

AT-L series 1-stage

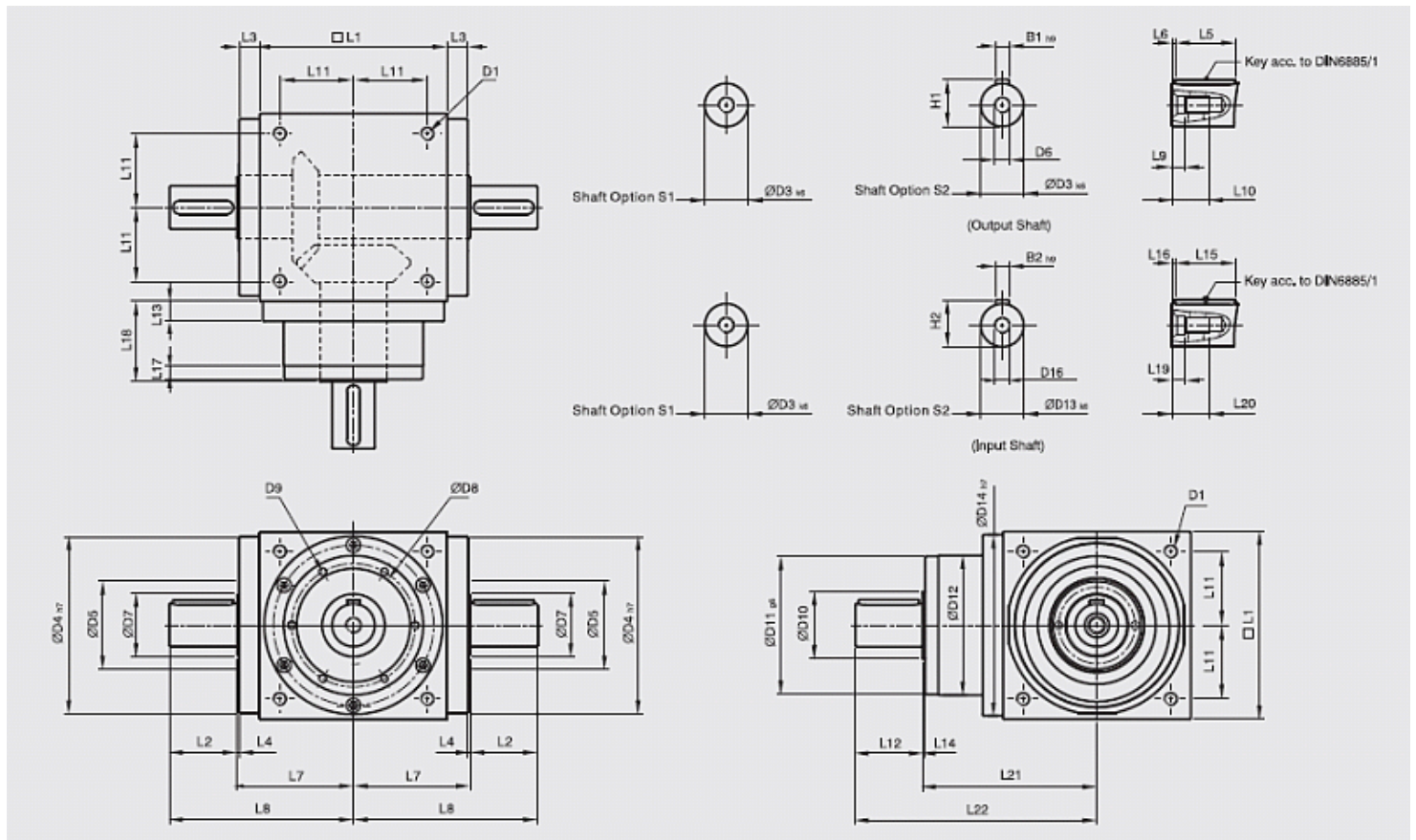

	AT065L	AT075L	AT090L	AT110L	AT140L	AT170L	AT210L	AT240L	AT280L
D1	M4	M6	M6	M8	M10	M12	M16	M16	M16
D3 _{k6}	13	16	18	22	32	40	50	55	60
D4 _{h7}	63	73	88	108	135	165	205	235	275
D5	31	35	43	53	68	83	104	124	144
D6	M4	M5	M5	M8	M12	M16	M16	M16	M20
D7	21	22	28	33	47	55	75	85	110
D8	53	62	76	95	92	114	142	160	176
D9	4 X M4 X L7	4 X M5 X L8	4 X M5 X L8	6 X M6 X L10	6 X M6 X L10	6 X M8 X L12.5	6 X M8 X L12.5	6 X M8 X L12.5	6 X M10 X L15
D10	15.4	20.4	25.8	35.8	49.8	59.3	79.3	92.3	102.3
D11 _{g6}	62.9	72.9	87	107	103	127	158	178	198
D12	62	72	86	106	104	128	160	180	200
D13 _{k6}	13	16	18	22	32	40	50	55	60
D14 _{h7}	63	73	88	108	135	165	205	235	275
D16	M4	M5	M5	M8	M12	M16	M16	M16	M20
L1	65	75	90	110	140	170	210	240	280
L2	19.5	30	35	40	50	60	75	85	110
L3	13	14.5	15	15	15	15	20	25	25
L4	2	2	2	2	2	2	2	2	2
L5	16	25	28	32	45	50	70	80	100
L6	2	2.5	3.5	4	2.5	5	2.5	2.5	5
L7	47.5	54	62	72	87	102	127	147	167
L8	67	84	97	112	137	162	202	232	277
L9	4.5	4.8	4.8	7.2	10	12	12	12	15
L10	10	12.5	12.5	19	28	36	36	36	42
L11	27	30	36	44	55	67	85	95	110
L12	19.5	30	35	40	50	60	75	85	110

L13	13	15	15	15	15	15	20	25	25
L14	2	2	2	2	2	2	2	2	2
L15	16	25	28	32	45	50	70	80	100
L16	2	2.5	3.5	4	2.5	5	2.5	2.5	5
L17	6	8	8	8	10	10	10	10	10
L18	43	52.5	55	60	60	70	90	105	120
L19	4.5	4.8	4.8	7.2	10	12	12	12	15
L20	10	12.5	12.5	19	28	36	36	36	42
L21	75.5	90	100	115	130	155	195	225	260
L22	95	120	135	155	180	215	270	310	370
B1 _{h9}	5	5	6	6	10	12	14	16	18
B2 _{h9}	5	5	6	6	10	12	14	16	18
H1	15	18	20.5	24.5	35	43	53.5	59	64
H2	15	18	20.5	24.5	35	43	53.5	59	64