



# APEX DYNAMICS, INC.



**High Precision  
Rack and Pinion**

## Main Features

**High Precision**  
**High Loading**  
**High Speed**  
**Low Noise**  
**Long Life-Time**  
**Quick Delivery**

APEX is the **ONLY ONE** manufacturer worldwide who produces rack strictly according to specifications regarding :

**Geometrical Tolerance of all Dimensions**  
**Defined Straightness, Parallelism and Perpendicularity**  
**Helical Angle and Pressure Angle with Tolerance**  
**Defined Surface Roughness of Teeth**  
**Defined Hardness and Thickness of the Hardened Layer on the Teeth.**

APEX is also the **ONLY ONE** of the world leading brands who designs and produces rack, pinion and gearbox by its own, and provides well coordinated high-quality transmission sets to fulfill different industrial requirements.

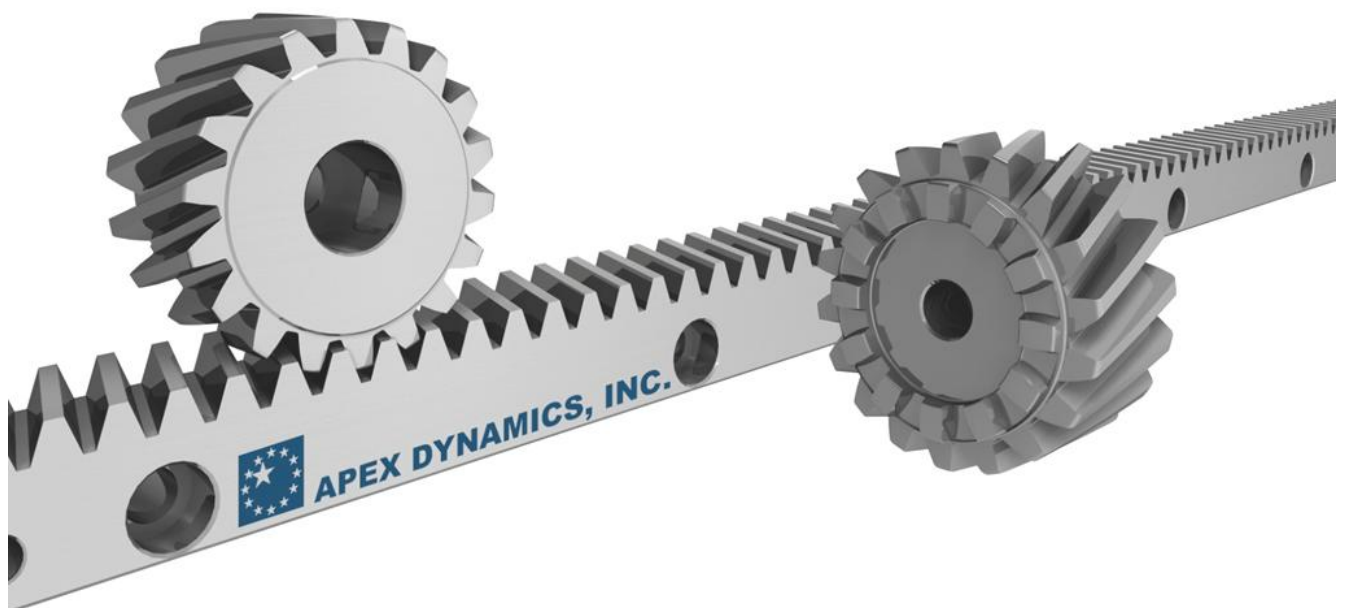

# Content

Requirement of High-Precision Rack	Page	3
Declaration of Tolerance		7
Induction Hardening for Rack		11
Heat-Treatment for Pinion		12
Rack Quality and Application		13
Rack Order Code		14
Rack with Helical Teeth		15
Rack with Helical Teeth ( with Linear-Guide Interface, 90° Type )		24
Rack with Helical Teeth ( with Linear-Guide Interface, 180° Type )		25
APEX High Precision Pinion		26
APEX Pinion with Curvic Plate		27
Pinion Order Code		28
Pinion with Helical Teeth ( Curvic Plate / EN ISO 9409-I-A )		29
Pinion with Helical Teeth ( Welded Plate / EN ISO 9409-I-A )		34
Pinion with Helical Teeth ( Teeth Plate / EN ISO 9409-I-A )		40
Pinion with Helical Teeth ( DIN 5480 / Spline )		45
Pinion with Helical Teeth ( Keyway for APEX AF- / PII-Series )		47
Pinion with Helical Teeth ( Keyway )		48
Rack with Straight Teeth		56
Rack with Straight Teeth ( with Linear-Guide Interface, 90° Type )		66
Rack with Straight Teeth ( with Linear-Guide Interface, 180° Type )		67
Pinion with Straight Teeth ( Curvic Plate / EN ISO 9409-I-A )		68
Pinion with Straight Teeth ( Welded Plate / EN ISO 9409-I-A )		73
Pinion with Straight Teeth ( Keyway )		78
Pinion with Straight Teeth ( Keyway / CP System )		87
Accessory		89
Rack Calculation and Selection		92

# Requirement of High-Precision Rack

Requirement and Reason	Technology needed
<p><b>Good Straightness, Less Torsion</b></p> <ul style="list-style-type: none"> <li>• Influence the accuracy of pressure angle, helical angle and pitch error, hence Influence the gear coupling with pinion.</li> <li>• To avoid re-straightening work after long-term stock due to slowly out-let of internal tension</li> </ul>	<ul style="list-style-type: none"> <li>➤ Heat-treatment</li> <li>➤ Straightening</li> <li>➤ Machining on all sides</li> <li>➤ Teeth milling and grinding</li> <li>➤ Teeth induction hardening</li> </ul>

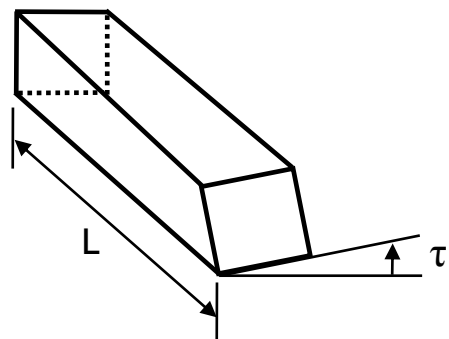
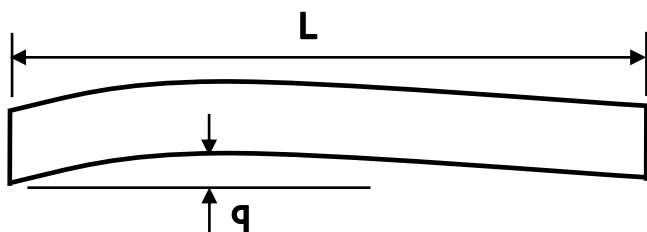

Requirement and Reason	Technology needed
<p><b>Accurate Pressure Angle <math>\alpha</math> and Helical Angle <math>\beta</math></b></p> <ul style="list-style-type: none"> <li>• Optimizing gear-coupling with pinion</li> <li>• Optimizing transmission of torque or feed force</li> <li>• For high speed, low noise, less wearing, longer life-time</li> </ul>	<ul style="list-style-type: none"> <li>➤ Heat-treatment</li> <li>➤ Straightening</li> <li>➤ Machining on all sides</li> <li>➤ Teeth milling and grinding</li> <li>➤ Teeth induction hardening</li> </ul>

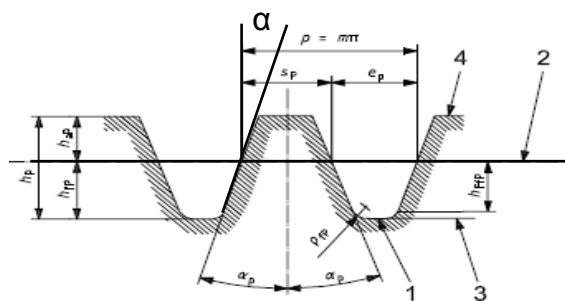
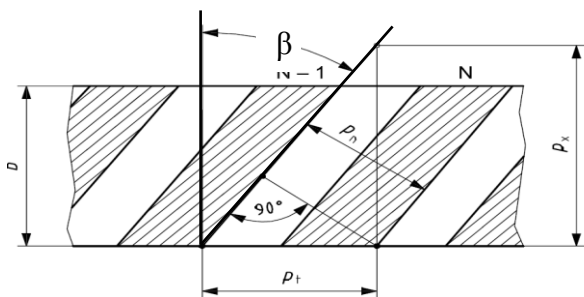
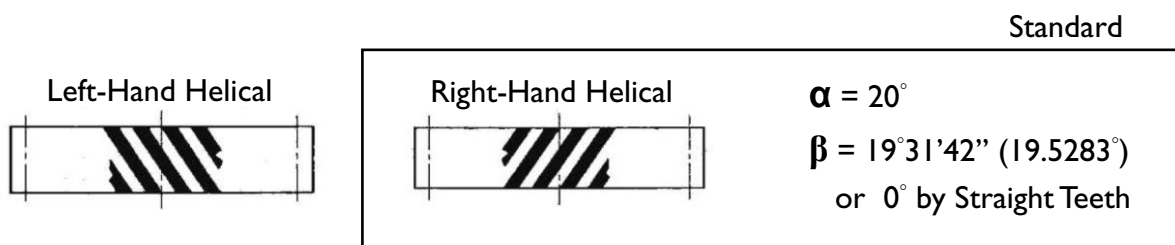

Requirement and Reason	Technology needed
<b>Accurate Over Pin Height H</b> <ul style="list-style-type: none"> <li>• A measure of accuracy of teeth profile</li> <li>• Optimizing gear-coupling with pinion</li> <li>• Influence on backlash between rack and pinion</li> </ul>	<ul style="list-style-type: none"> <li>➤ Heat-treatment</li> <li>➤ Straightening</li> <li>➤ Machining on all sides</li> <li>➤ Teeth milling and grinding</li> <li>➤ Teeth induction hardening</li> </ul>

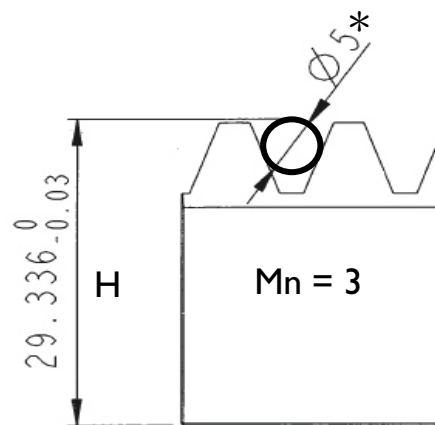

\* Pin Diameter depending on Mn.

Requirement and Reason	Technology needed
<b>Low Single Pitch Error Es / Low Total Pitch Error Et</b> <ul style="list-style-type: none"> <li>• Optimizing gear-coupling with pinion</li> <li>• Low noise, less wearing, longer life-time</li> <li>• High positioning accuracy</li> <li>• Influence on backlash</li> </ul>	<ul style="list-style-type: none"> <li>➤ Heat-treatment</li> <li>➤ Straightening</li> <li>➤ Machining on all sides</li> <li>➤ Teeth milling and grinding</li> <li>➤ Teeth induction hardening</li> </ul>

- Pitch =  $\pi \times$  Module No.
- Total Pitch Error Et is to be measured between the first and the last tooth of a rack.

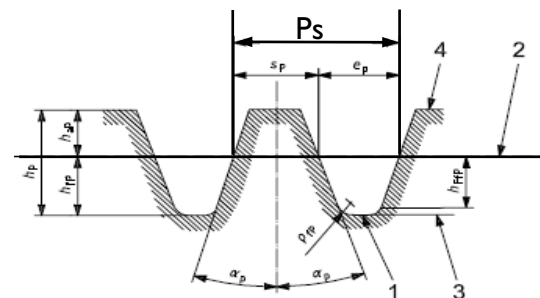
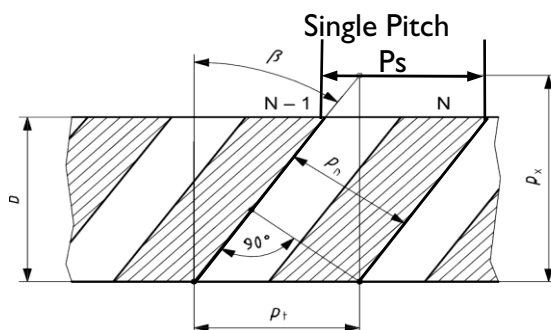

# Requirement of High-Precision Rack

Requirement and Reason	Technology needed
<b>Rigidity / Material Hardness</b> <ul style="list-style-type: none"> <li>• No deformation during gear coupling with Pinion</li> <li>• High strength of rack / High strength of teeth</li> <li>• Transmission of high torque or high feed force</li> <li>• High speed, less wearing, long life-time</li> </ul>	<ul style="list-style-type: none"> <li>➤ Heat-treatment</li> <li>➤ Teeth induction hardening</li> </ul>

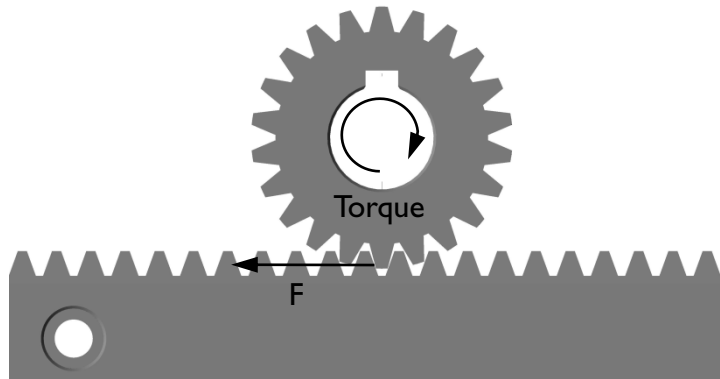

Requirement and Reason	Technology needed
<b>High Surface Hardness</b> <ul style="list-style-type: none"> <li>• High strength of rack / High strength of teeth</li> <li>• Transmission of high torque or high feed force</li> <li>• High wearing resistance</li> </ul>	<ul style="list-style-type: none"> <li>➤ Heat-treatment</li> <li>➤ Induction hardening</li> <li>➤ Teeth grinding</li> </ul>
<b>Thickness of Hardened-Layer</b> <ul style="list-style-type: none"> <li>• Preserve accuracy and long lift-time</li> </ul>	
<b>Symmetry of Hardened-Layer on teeth profiles</b> <ul style="list-style-type: none"> <li>• Preserve accuracy and long lift-time in both moving directions on the rack</li> </ul>	



Qualified induction hardening and teeth grinding

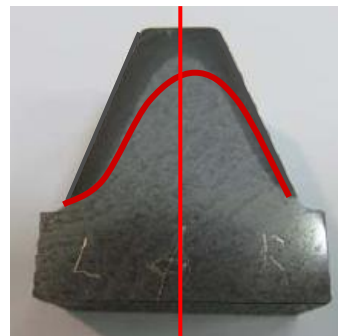

Bad induction hardening and / or bad teeth grinding

Requirement and Reason	Technology needed
<p><b>Low Remaining Magnet</b></p> <ul style="list-style-type: none"> <li>• Prevent adhesion of particles between the rack and pinion which leads to pitting and damage the teeth profile.</li> <li>• Smooth running</li> <li>• Preserve accuracy and long lift-time</li> </ul>	<p>➤ Degauss device</p>

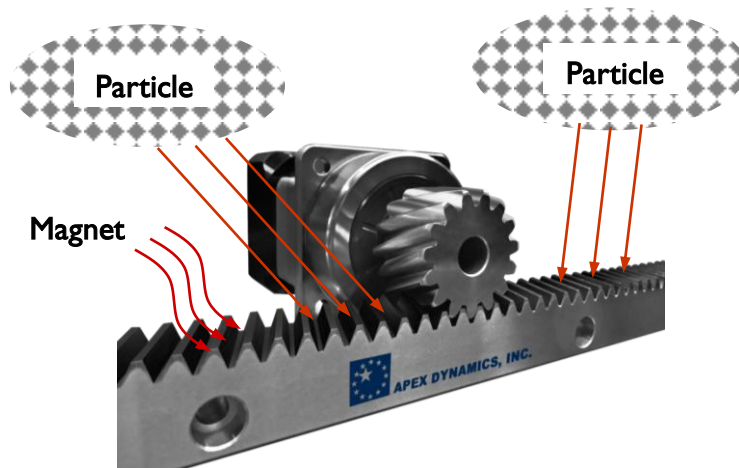

APEX rack has been degaussed until  $10 \pm 3$  Gauss!

Requirement and Reason	Technology needed
<p><b>Magnetic Crack Inspection</b></p> <ul style="list-style-type: none"> <li>• Preserve accuracy</li> <li>• Guarantee of long life-time</li> </ul>	<p>➤ Magnetic crack inspection device</p>

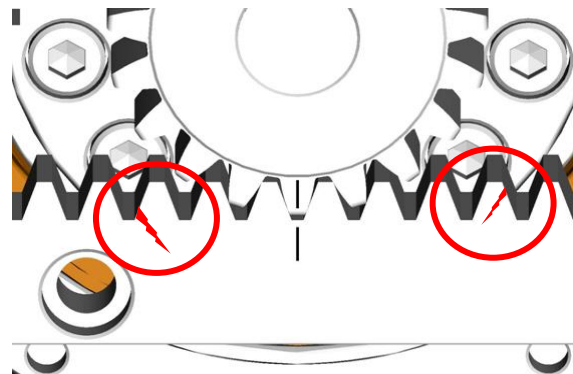
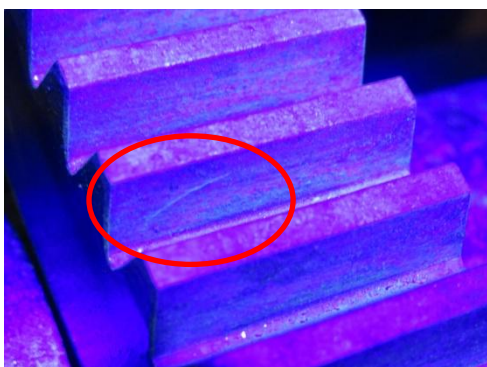

APEX rack has been checked by Magnetic Crack Inspection Device!

# Declaration of Tolerance

## Parallelism and Perpendicularity

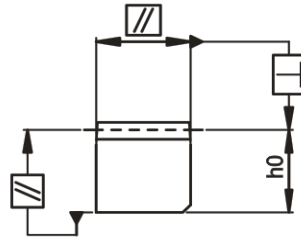

Quality	Q4 ~ Q5		Q6		Q6M		Q8 / Q9		Q10	
> 10 ~ 16	0.004	0.006	0.006	0.01	0.015	0.025	0.025	0.04	0.04	0.06
> 16 ~ 25	0.005	0.008	0.008	0.012	0.02	0.03	0.03	0.05	0.05	0.08
> 25 ~ 40	0.006	0.01	0.01	0.015	0.025	0.04	0.04	0.06	0.06	0.1
> 40 ~ 63	0.008	0.012	0.012	0.02	0.03	0.05	0.05	0.08	0.08	0.12
> 63 ~ 100	0.01	0.015	0.015	0.025	0.04	0.06	0.06	0.1	0.1	0.15
> 100 ~ 160	0.012	0.02	0.02	0.03	0.05	0.08	0.08	0.12	0.12	0.2

## Straightness \*

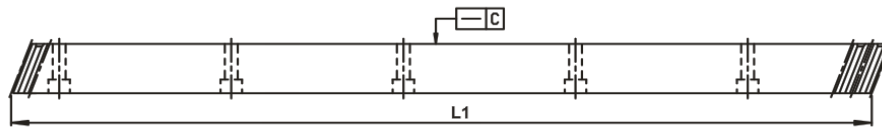

Quality	Q 4 ~ Q 6		Q 6M		Q 8 ~ Q 9		Q 10	
	Fixed	Free	Fixed	Free	Fixed	Free	Fixed	Free
M1~M2, milled	-	-	0.04	0.45	0.05	0.45	0.08	0.5
M1~M2, ground	0.02	0.4	-	-	-	-	-	-
M3~M6, milled	-	-	0.04	0.45	0.05	0.45	0.08	0.5
M3~M6, ground	0.02	0.3	-	-	-	-	-	-
M8~M12, milled	-	-	0.04	0.45	0.05	0.45	0.08	0.5
M8~M12, ground	0.02	0.25	-	-	-	-	-	-

\* Straightness is given either in a free situation (Free) or on a certified flat surface in a fixed mounted situation (Fixed). By the Free-case, the rack is lying on the certified surface with its teeth at the side.

## Surface Roughness

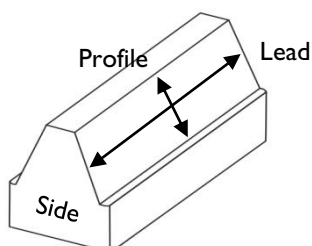

Quality	Q 4 ~ Q 6	Q 6M	Q 8 ~ Q 9	Q 10
Lead	$Ra \leq 0.5$	$Ra \leq 0.5$	$Ra \leq 1.0$	$Ra \leq 1.6$
Profile	$Ra \leq 1.0$	$Ra \leq 1.0$	$Ra \leq 3.0$	$Ra \leq 6.3$
Side	$Ra \leq 0.8$	$Ra \leq 2.0$	$Ra \leq 2.0$	$Ra \leq 2.0$



## Tolerance of Rack Teeth

APEX declares clearly all the tolerances of rack dimension and geometry, beginning from the design through out the manufacturing.

### Pressure Angle Deviation

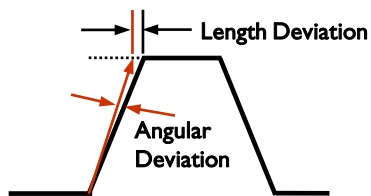

### Height Deviation

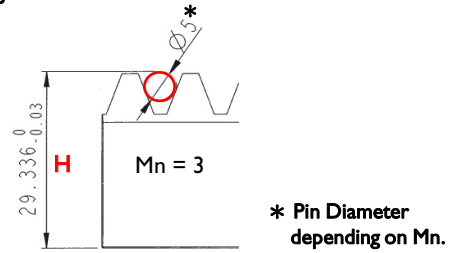

### Helical Angle Deviation

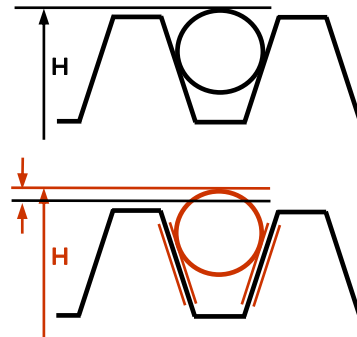
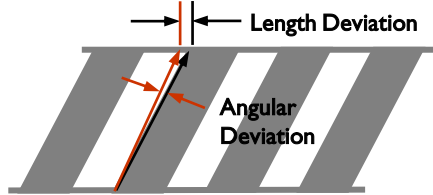

### Single Pitch Error

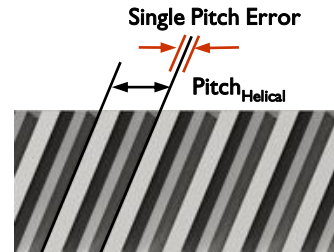
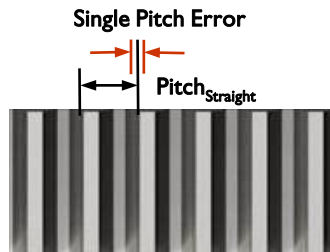

### Total Pitch Error

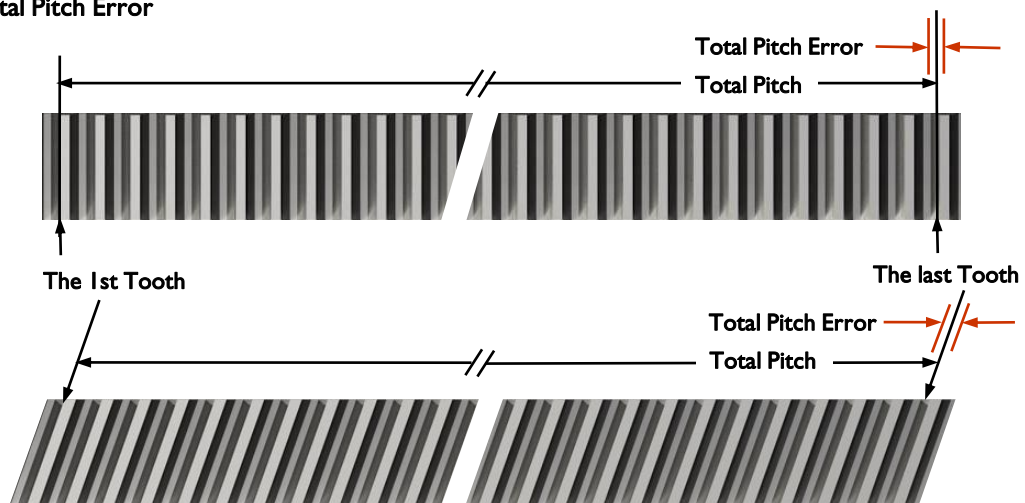

# Declaration of Tolerance

## Precision / Tolerance of Rack Teeth

Module No.	Deviation	Q4	Q5H / Q5	Q6 / Q6M	Q8H / Q8	Q9	Q10
1	Pressure Angle Deviation (μm)	≤ 4	≤ 6	≤ 8	≤ 16	≤ 23	≤ 36
	Helical Angle Deviation (μm)	≤ 6	≤ 7	≤ 9	≤ 18	≤ 28	≤ 45
	Over Pin Height Deviation (μm)	0	0	0	0	0	0
		- 19	- 21	- 30	- 66	-87	- 124
	Single Pitch Error (I) (μm)	≤ 4.5	≤ 6	≤ 8	≤ 16	≤ 23	≤ 37
Total Pitch Error (I) (μm)	≤ 17	≤ 24	≤ 33	≤ 65	≤ 91	≤ 146	

Module No.	Deviation	Q4	Q5H / Q5	Q6 / Q6M	Q8H / Q8	Q9	Q10
1.5	Pressure Angle Deviation (μm)	≤ 4	≤ 6	≤ 8	≤ 16	≤ 23	≤ 36
	Helical Angle Deviation (μm)	≤ 6	≤ 7	≤ 9	≤ 18	≤ 28	≤ 45
	Over Pin Height Deviation (μm)	0	0	0	0	0	0
		- 19	- 21	- 30	- 66	-87	- 124
	Single Pitch Error (I) (μm)	≤ 4.5	≤ 6	≤ 8	≤ 16	≤ 23	≤ 37
Total Pitch Error (I) (μm)	≤ 17	≤ 24	≤ 34	≤ 66	≤ 91	≤ 148	

Module No.	Deviation	Q4	Q5H / Q5	Q6 / Q6M	Q8H / Q8	Q9	Q10
2	Pressure Angle Deviation (μm)	≤ 4	≤ 6	≤ 8	≤ 16	≤ 23	≤ 36
	Helical Angle Deviation (μm)	≤ 6.5	≤ 8	≤ 10	≤ 20	≤ 32	≤ 52
	Over Pin Height Deviation (μm)	0	0	0	0	0	0
		- 19	- 20	- 30	- 66	-87	- 123
	Single Pitch Error (I) (μm)	≤ 4.5	≤ 6	≤ 8	≤ 16	≤ 23	≤ 37
Total Pitch Error (I) (μm)	≤ 17	≤ 24	≤ 34	≤ 66	≤ 91	≤ 148	

Module No.	Deviation	Q4	Q5H / Q5	Q6 / Q6M	Q8H / Q8	Q9	Q10
2.5	Pressure Angle Deviation (μm)	≤ 5	≤ 7	≤ 10	≤ 20	≤ 28	≤ 45
	Helical Angle Deviation (μm)	≤ 6.5	≤ 8	≤ 10	≤ 20	≤ 32	≤ 52
	Over Pin Height Deviation (μm)	0	0	0	0	0	0
		- 19	- 21	- 30	- 66	-87	- 124
	Single Pitch Error (I) (μm)	≤ 4.5	≤ 6	≤ 9	≤ 18	≤ 25	≤ 39
Total Pitch Error (I) (μm)	≤ 19	≤ 26	≤ 36	≤ 72	≤ 100	≤ 160	

Module No.	Deviation	Q4	Q5H / Q5	Q6 / Q6M	Q8H / Q8	Q9	Q10
3	Pressure Angle Deviation (μm)	≤ 5	≤ 7	≤ 10	≤ 20	≤ 28	≤ 45
	Helical Angle Deviation (μm)	≤ 6.5	≤ 8	≤ 10	≤ 20	≤ 32	≤ 52
	Over Pin Height Deviation (μm)	0	0	0	0	0	0
		- 19	- 21	- 30	- 66	-87	- 124
	Single Pitch Error (I) (μm)	≤ 4.5	≤ 6	≤ 9	≤ 18	≤ 25	≤ 39
Total Pitch Error (I) (μm)	≤ 19	≤ 26	≤ 37	≤ 72	≤ 101	≤ 162	

Module No.	Deviation	Q4	Q5H / Q5	Q6 / Q6M	Q8H / Q8	Q9	Q10
4	Pressure Angle Deviation (μm)	≤ 7	≤ 9	≤ 13	≤ 25	≤ 35	≤ 56
	Helical Angle Deviation (μm)	≤ 6.5	≤ 8	≤ 10	≤ 20	≤ 32	≤ 52
	Over Pin Height Deviation (μm)	0	0	0	0	0	0
		- 19	- 21	- 30	- 66	- 66	- 124
	Single Pitch Error (I) (μm)	≤ 5	≤ 7	≤ 10	≤ 19	≤ 18	≤ 43
Total Pitch Error (I) (μm)	≤ 20	≤ 28	≤ 40	≤ 78	≤ 72	≤ 175	

(I) For helical and straight teeth, basing on the nominal length 1000 mm.  
Straightness is to measure on a certified flat surface in a fix mounted situation.

## Precision / Tolerance of Rack Teeth

Module No.	Deviation	Q4	Q5H / Q5	Q6 / Q6M	Q8H / Q8	Q9	Q10
5	Pressure Angle Deviation ( $\mu\text{m}$ )	$\leq 7$	$\leq 9$	$\leq 13$	$\leq 25$	$\leq 35$	$\leq 56$
	Helical Angle Deviation ( $\mu\text{m}$ )	$\leq 8$	$\leq 10$	$\leq 13$	$\leq 25$	$\leq 41$	$\leq 65$
	Over Pin Height Deviation ( $\mu\text{m}$ )	0	0	0	0	0	0
		-19	-21	-30	-66	-87	-124
	Single Pitch Error (I) ( $\mu\text{m}$ )	$\leq 5$	$\leq 7$	$\leq 10$	$\leq 19$	$\leq 27$	$\leq 43$
Total Pitch Error (I) ( $\mu\text{m}$ )	$\leq 20$	$\leq 28$	$\leq 40$	$\leq 78$	$\leq 109$	$\leq 175$	

Module No.	Deviation	Q4	Q5H / Q5	Q6 / Q6M	Q8H / Q8	Q9	Q10
6	Pressure Angle Deviation ( $\mu\text{m}$ )	$\leq 7$	$\leq 9$	$\leq 13$	$\leq 25$	$\leq 35$	$\leq 56$
	Helical Angle Deviation ( $\mu\text{m}$ )	$\leq 8$	$\leq 10$	$\leq 13$	$\leq 25$	$\leq 41$	$\leq 65$
	Over Pin Height Deviation ( $\mu\text{m}$ )	0	0	0	0	0	0
		-19	-21	-30	-66	-87	-124
	Single Pitch Error (I) ( $\mu\text{m}$ )	$\leq 5$	$\leq 7$	$\leq 10$	$\leq 19$	$\leq 27$	$\leq 43$
Total Pitch Error (I) ( $\mu\text{m}$ )	$\leq 20$	$\leq 28$	$\leq 40$	$\leq 78$	$\leq 109$	$\leq 175$	

Module No.	Deviation	Q4	Q5H / Q5	Q6 / Q6M	Q8H / Q8	Q9	Q10
8	Pressure Angle Deviation ( $\mu\text{m}$ )	$\leq 8$	$\leq 12$	$\leq 16$	$\leq 32$	$\leq 45$	$\leq 72$
	Helical Angle Deviation ( $\mu\text{m}$ )	$\leq 8$	$\leq 10$	$\leq 13$	$\leq 25$	$\leq 41$	$\leq 65$
	Over Pin Height Deviation ( $\mu\text{m}$ )	0	0	0	0	0	0
		-20	-21	-31	-66	-87	-124
	Single Pitch Error (I) ( $\mu\text{m}$ )	$\leq 5.5$	$\leq 8$	$\leq 11$	$\leq 22$	$\leq 31$	$\leq 49$
Total Pitch Error (I) ( $\mu\text{m}$ )	$\leq 22$	$\leq 31$	$\leq 43$	$\leq 84$	$\leq 118$	$\leq 188$	

Module No.	Deviation	Q4	Q5H / Q5	Q6 / Q6M	Q8H / Q8	Q9	Q10
10	Pressure Angle Deviation ( $\mu\text{m}$ )	$\leq 8$	$\leq 12$	$\leq 16$	$\leq 32$	$\leq 45$	$\leq 72$
	Helical Angle Deviation ( $\mu\text{m}$ )	$\leq 8$	$\leq 10$	$\leq 13$	$\leq 25$	$\leq 41$	$\leq 65$
	Over Pin Height Deviation ( $\mu\text{m}$ )	0	0	0	0	0	0
		-20	-21	-31	-66	-87	-124
	Single Pitch Error (I) ( $\mu\text{m}$ )	$\leq 5.5$	$\leq 8$	$\leq 11$	$\leq 22$	$\leq 31$	$\leq 49$
Total Pitch Error (I) ( $\mu\text{m}$ )	$\leq 22$	$\leq 31$	$\leq 43$	$\leq 84$	$\leq 118$	$\leq 188$	

Module No.	Deviation	Q4	Q5H / Q5	Q6 / Q6M	Q8H / Q8	Q9	Q10
12	Pressure Angle Deviation ( $\mu\text{m}$ )	$\leq 11$	$\leq 15$	$\leq 21$	$\leq 42$	$\leq 58$	$\leq 93$
	Helical Angle Deviation ( $\mu\text{m}$ )	$\leq 10$	$\leq 13$	$\leq 16$	$\leq 32$	$\leq 51$	$\leq 82$
	Over Pin Height Deviation ( $\mu\text{m}$ )	0	0	0	0	0	0
		-20	-21	-31	-66	-87	-124
	Single Pitch Error (I) ( $\mu\text{m}$ )	$\leq 7$	$\leq 10$	$\leq 13$	$\leq 26$	$\leq 37$	$\leq 59$
Total Pitch Error (I) ( $\mu\text{m}$ )	$\leq 23$	$\leq 33$	$\leq 46$	$\leq 90$	$\leq 126$	$\leq 202$	

- (I) For helical and straight teeth, basing on the nominal length 1000 mm.  
Straightness is to measure on a certified flat surface in a fix mounted situation.

# Induction Hardening for Rack

Scanning Induction Hardening

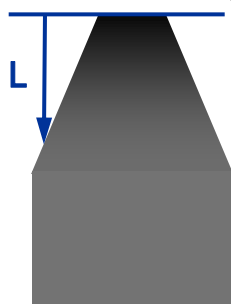

Tooth-by-Tooth Induction Hardening

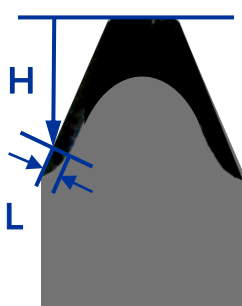

Carburized Induction Hardening

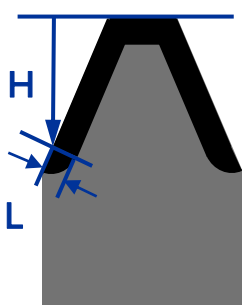

Induction Hardening		
Surface Hardness	Hardness by Effective Thickness L	
550 ± 40 HV	440 ± 32 HV	
Module No.	H	L
1	-	1.75
1.5	-	2.63
1.591 (Pitch 5)	-	2.79
2	-	3.5
2.5	-	4.38
3	-	4.8
3.183 (Pitch 10)	-	5.09

Module No.	H	L
4	7.2	0.3
4.244 (Pitch 13.33)	7.64	0.3
5	9	0.3
6	10.8	0.3
8	14.4	0.3
10	18	0.3
12	21.6	0.3

Carburized Induction Hardening		
Surface Hardness	Hardness by Effective Thickness L	
640 ~ 720 HV	515 ~ 580 HV	
Module No.	H	L
2	3.5	0.4
2.5	4.38	0.48
3	4.8	0.55
4	6	0.68
5	10	0.88
6	12	1.03
8	16	0.91
10	20	0.87

Note : In the cross-section, the effective thickness can be guaranteed over 80% in the middle of the teeth width.

# Heat-Treatment for Pinion

Material : Alloy Steel

Heat-Treatment : Case Hardening

Teeth : Ground

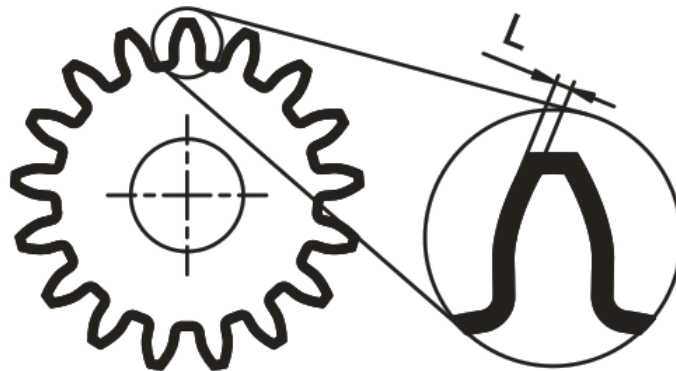

Induction Hardening	
Surface Hardness	Hardness by Effective Thickness L
640 ~ 720 HV	515 ~ 580 HV

(The surface hardness is measured at the pitch circle.)

Mn	L (in mm)
1.5	0.3
1.591 ( Pitch 5 )	0.3
2	0.3
2.5	0.38
3	0.45
3.183 ( Pitch 10 )	0.48
4	0.6
4.244 ( Pitch 13.33 )	0.64
5	0.75
6	0.9
8	1.2
10	1.5

# Rack Quality and Application

Quality	Module	Total Pitch Error (μm / 1000mm)	Tooth Thickness Tolerance (μm)	Application
4	5 ~ 12	20 ~ 23	-13 ~ 0	<ul style="list-style-type: none"> <li>• Measurement equipment</li> <li>• Certification laboratory</li> <li>• High-end machine tools with electrical Preload</li> </ul>
5H	2 ~ 10	24 ~ 31	-15 ~ 0	<ul style="list-style-type: none"> <li>• For the installation without back support</li> <li>• High rigidity / high torque</li> <li>• Multi-pinion application</li> <li>• To replace lager module-no.</li> </ul>
5	2 ~ 12	24 ~ 33	-15 ~ 0	<ul style="list-style-type: none"> <li>• High-end machine tools</li> <li>• Lifting axis</li> <li>• Multi-pinion application</li> </ul>
6	1 ~ 12	33 ~ 46	-22 ~ 0	<ul style="list-style-type: none"> <li>• Machine tools</li> <li>• Water-/ laser-/ plasma-cutting machines</li> <li>• Portal machine center</li> <li>• Tube bending machine</li> <li>• Woodworking machine</li> <li>• Combination with linear guide</li> </ul>
6M	2 ~ 10	34 ~ 43	-22 ~ 0	<ul style="list-style-type: none"> <li>• Combination with linear guide</li> <li>• Automatic loading system</li> </ul>
8H	2 ~ 4	66 ~ 78	-48 ~ 0	<ul style="list-style-type: none"> <li>• Welding machine</li> <li>• Robots</li> <li>• Automatic loading system</li> <li>• Linear axis with low load feed</li> </ul>
8	1.5 ~ 12	66 ~ 90	-48 ~ 0	<ul style="list-style-type: none"> <li>• Welding machine</li> <li>• Robots</li> <li>• Automatic loading system</li> <li>• Linear axis with low load feed</li> </ul>
9	1 ~ 6	91 ~ 109	-63 ~ 0	<ul style="list-style-type: none"> <li>• Stainless</li> <li>• Food industry / pharmaceutical industry</li> <li>• Clean room application</li> </ul>
10	1 ~ 12	146 ~ 202	-90 ~ 0	<ul style="list-style-type: none"> <li>• Lifting axis</li> <li>• Automatic loading system</li> <li>• Robots</li> <li>• Outdoor application</li> </ul>

# Rack Order Code

Example : 02 06 R 100 C I 0 ( )

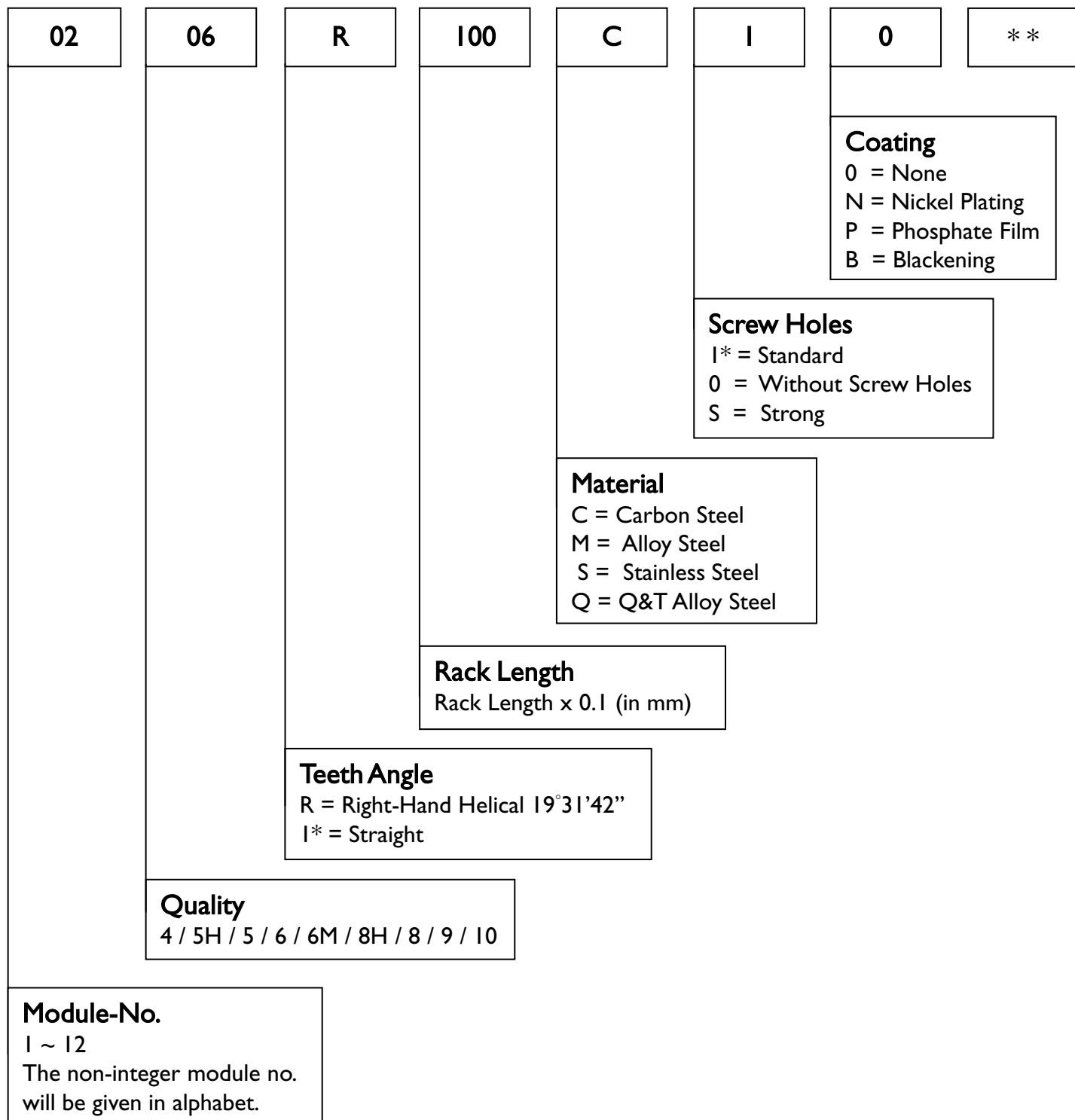

\* I = " one "

\*\* A1 = For Linear-Guide Interface, 90° Type  
 A2 = For Linear-Guide Interface, 180° Type

# Rack with Helical Teeth

Quality 4 / Carbon Steel  
 Tooth Thickness Tolerance : -13 ~ 0 μm  
 Right-Hand Helical Teeth  
 Teeth Induction Hardened and Ground  
 All Sides Ground

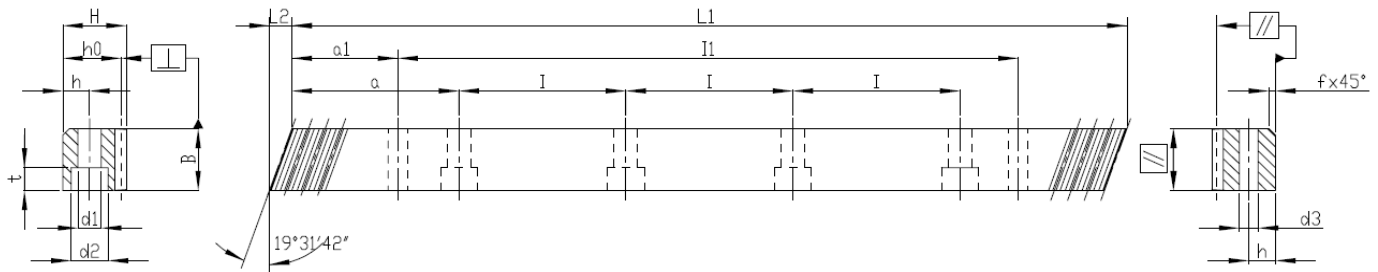

Mn	Pt <sup>(1)</sup>	L1	L2	Teeth No.	B	H	h <sub>0</sub>	f	a	I	Hole No.	h	d1	d2	t	a1	I1	d3	f <sub>p</sub> <sup>(2)</sup>	F <sub>p</sub> <sup>(3)</sup>	Order Code *
5	16.66669	1000	17.4	60	49	39	34	3	62.5	125	8	12	14	20	13	37.5	925	11.7	0.005	0.020	0504R100C10
6	20.00003	1000	20.9	50	59	49	43	3	62.5	125	8	16	18	26	17	37.5	925	15.7	0.005	0.020	0604R100C10
8	26.66671	960	28.0	36	79	79	71	3	60.0	120	8	25	22	33	21	120.0	720	19.7	0.006	0.022	0804R100C10
10	33.33339	1000	35.1	30	99	99	89	3	62.5	125	8	32	33	48	32	125.0	750	19.7	0.006	0.022	1004R100C10
12	40.00006	1000	42.6	25	120	120	108	3	40.0	125	8	40	39	58	38	102.5	750	19.7	0.007	0.023	1204R100C10

(1) Teeth Pitch Pt = Module x π / cos (19°31'42" )    (2) f<sub>p</sub> = Single Pitch Error    (3) F<sub>p</sub> = Total Pitch Error

\* For all models APEX also provides Rack without screw-holes. By ordering please change the 2nd last order-code position from "1" to "0". Please also refer to page 14.



Quality 5H / Alloy Steel  
 Tooth Thickness Tolerance : -15 ~ 0  $\mu\text{m}$   
 Right-Hand Helical Teeth  
 Material Case-Hardened  
 Teeth Ground and all Sides Ground

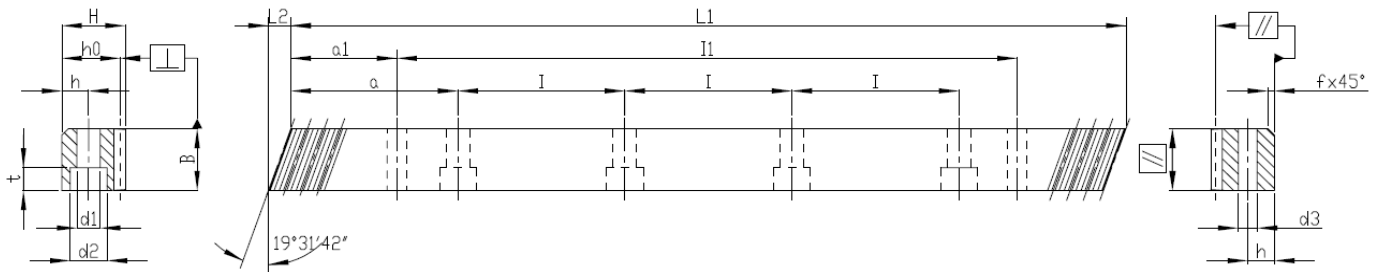

Mn	P <sub>t</sub> <sup>(1)</sup>	L1	L2	Teeth No.	B	H	h <sub>o</sub>	f	a	l	Hole No.	h	d1	d2	t	a1	II	d3	f <sub>p</sub> <sup>(2)</sup>	F <sub>p</sub> <sup>(3)</sup>	Order Code *
2	6.66668	1000	8.5	150	24	24	22	2	62.5	125	8	9	10	15	9	31.7	936.6	7.7	0.006	0.024	025HR100M10
3	10.00002	1000	10.3	100	29	29	26	2	62.5	125	8	10	12	17.5	11	27.5	945.0	11.7	0.006	0.026	035HR100M10
4	13.33335	1000	13.8	75	39	39	35	3	62.5	125	8	13	16	23	15	30.0	940.0	15.7	0.007	0.028	045HR100M10
5	16.66669	1000	17.4	60	49	49	44	3	62.5	125	8	15	18	26	17	34.5	931.0	15.7	0.007	0.028	055HR100M10
6	20.00003	1000	20.9	50	59	59	53	3	62.5	125	8	20	22	33	21	97.5	805.0	19.7	0.007	0.028	065HR100M10
8	26.66671	960	28.0	36	79	79	71	3	60.0	120	8	25	26	39	25	120.0	720.0	19.7	0.008	0.031	085HR100M10
10	33.33339	1000	35.1	30	99	99	89	3	40.0	125	8	32	39	58	38	102.5	750.0	19.7	0.008	0.031	105HR100M10

(1) Teeth Pitch Pt = Module  $\times \pi / \cos (19^{\circ}31'42'')$     (2) f<sub>p</sub> = Single Pitch Error    (3) F<sub>p</sub> = Total Pitch Error

\* For all models APEX also provides Rack without screw-holes. By ordering please change the 2nd last order-code position from "I" to "0". Please also refer to page 14.

Especially for the application without back-support.

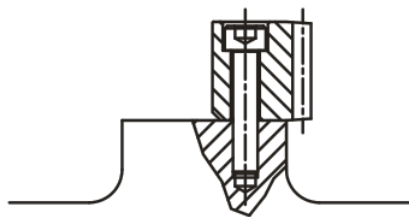

Without alignment / back-support

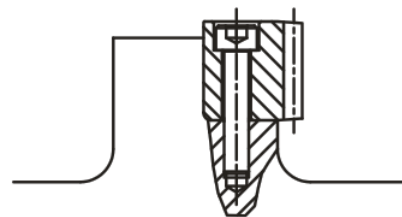

With alignment / back-support

# Rack with Helical Teeth

Quality 5 / Alloy Steel  
 Tooth Thickness Tolerance : -15 ~ 0  $\mu\text{m}$   
 Right-Hand Helical Teeth  
 Material Carburized, Induction Hardened  
 Teeth Ground and all Sides Ground

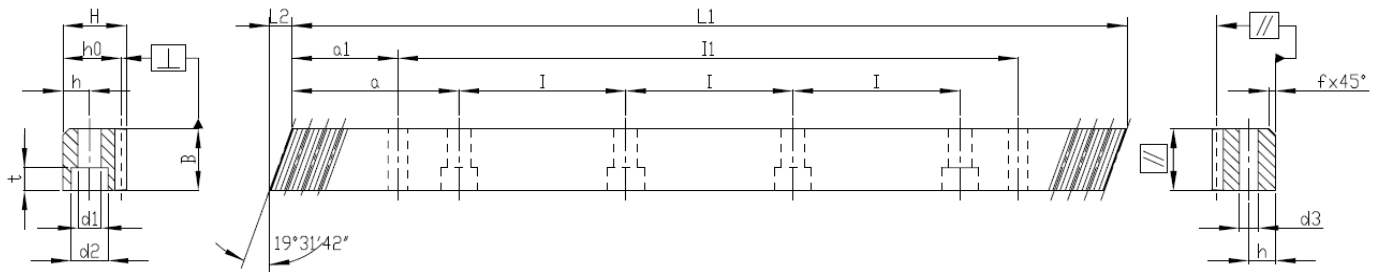

Mn	P <sub>t</sub> <sup>(1)</sup>	L1	L2	Teeth No.	B	H	h <sub>0</sub>	f	a	I	Hole No.	h	d1	d2	t	a1	II	d3	f <sub>p</sub> <sup>(2)</sup>	F <sub>p</sub> <sup>(3)</sup>	Order Code*
2	6.66668	500	8.5	75	24	24	22.0	2	62.5	125	4	8	7	11	7	31.7	436.6	5.7	0.006	0.021	0205R050M10
2	6.66668	1000	8.5	150	24	24	22.0	2	62.5	125	8	8	7	11	7	31.7	936.6	5.7	0.006	0.024	0205R100M10
2	6.66668	1500	8.5	225	24	24	22.0	2	62.5	125	12	8	7	11	7	31.7	1436.6	5.7	0.006	0.024	0205R150M10
2	6.66668	2000	8.5	300	24	24	22.0	2	62.5	125	16	8	7	11	7	31.7	1936.6	5.7	0.007	0.027	0205R200M10
2.5	8.33335	500	10.3	60	29	29	26.5	2	62.5	125	4	9	10	15	9	35.0	430.0	7.7	0.006	0.023	2J05R050M10
2.5	8.33335	1000	10.3	120	29	29	26.5	2	62.5	125	8	9	10	15	9	35.0	930.0	7.7	0.006	0.026	2J05R100M10
2.5	8.33335	1500	10.3	180	29	29	26.5	2	62.5	125	12	9	10	15	9	35.0	1430.0	7.7	0.006	0.026	2J05R150M10
2.5	8.33335	2000	10.3	240	29	29	26.5	2	62.5	125	16	9	10	15	9	35.0	1930.0	7.7	0.007	0.029	2J05R200M10
3	10.00002	500	10.3	50	29	29	26.0	2	62.5	125	4	9	10	15	9	35.0	430.0	7.7	0.006	0.023	0305R050M10
3	10.00002	1000	10.3	100	29	29	26.0	2	62.5	125	8	9	10	15	9	35.0	930.0	7.7	0.006	0.026	0305R100M10
3	10.00002	1500	10.3	150	29	29	26.0	2	62.5	125	12	9	10	15	9	35.0	1430.0	7.7	0.006	0.026	0305R150M10
3	10.00002	2000	10.3	200	29	29	26.0	2	62.5	125	16	9	10	15	9	35.0	1930.0	7.7	0.007	0.030	0305R200M10

(1) Teeth Pitch Pt = Module  $\times \pi / \cos (19^{\circ}31'42'')$  (2) f<sub>p</sub> = Single Pitch Error (3) F<sub>p</sub> = Total Pitch Error

\* For all models APEX also provides Rack without screw-holes. By ordering please change the 2nd last order-code position from "I" to "0". Please also refer to page 14.

Quality 5 / Carbon Steel  
 Tooth Thickness Tolerance : -15 ~ 0 μm  
 Right-Hand Helical Teeth  
 Teeth Induction Hardened and Ground  
 All Sides Ground

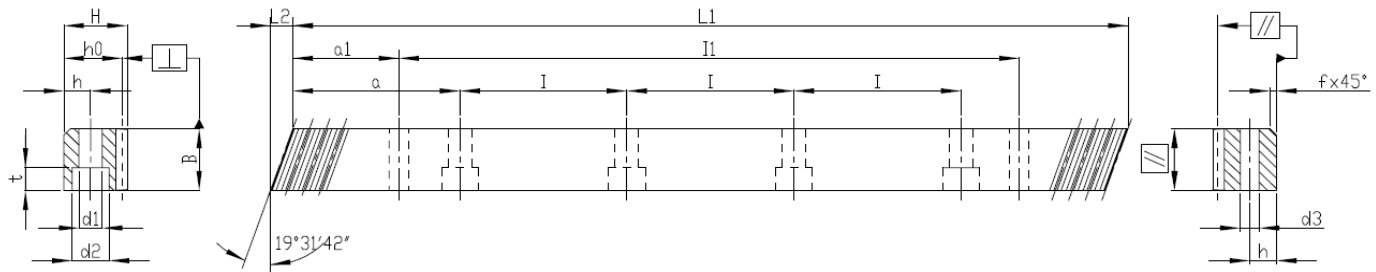

Mn	Pt <sup>(1)</sup>	L1	L2	Teeth No.	B	H	h <sub>0</sub>	f	a	I	Hole No.	h	d1	d2	t	a1	II	d3	f <sub>p</sub> <sup>(2)</sup>	F <sub>p</sub> <sup>(3)</sup>	Order Code *
4	13.33335	506.67	13.8	38	39	39	35	3	62.5	125	4	12	10	15	9	33.3	440.1	7.7	0.007	0.025	0405R050C10
4	13.33335	1000	13.8	75	39	39	35	3	62.5	125	8	12	10	15	9	33.3	933.4	7.7	0.007	0.028	0405R100C10
4	13.33335	1000	13.8	75	39	39	35	3	62.5	125	8	12	14	20	13	33.3	933.4	11.7	0.007	0.028	0405R100CS0
4	13.33335	1506.67	13.8	113	39	39	35	3	62.5	125	12	12	10	15	9	33.3	1440.1	7.7	0.007	0.028	0405R150C10
4	13.33335	1506.67	13.8	113	39	39	35	3	62.5	125	12	12	14	20	13	33.3	1440.1	11.7	0.007	0.028	0405R150CS0
4	13.33335	2000	13.8	150	39	39	35	3	62.5	125	16	12	10	15	9	33.3	1933.4	7.7	0.008	0.032	0405R200C10
4	13.33335	2000	13.8	150	39	39	35	3	62.5	125	16	12	14	20	13	33.3	1933.4	11.7	0.008	0.032	0405R200CS0
5	16.66669	1000	17.4	60	49	39	34	3	62.5	125	8	12	14	20	13	37.5	925	11.7	0.007	0.028	0505R100C10
6	20.00003	1000	20.9	50	59	49	43	3	62.5	125	8	16	18	26	17	37.5	925	15.7	0.007	0.028	0605R100C10
8	26.66671	960	28	36	79	79	71	3	60	120	8	25	22	33	21	120	720	19.7	0.008	0.031	0805R100C10
10	33.33339	1000	35.1	30	99	99	89	3	62.5	125	8	32	33	48	32	125	750	19.7	0.008	0.031	1005R100C10
12	40.00006	1000	42.6	25	120	120	108	3	40	125	8	40	39	58	38	102.5	750	19.7	0.01	0.033	1205R100C10

(1) Teeth Pitch Pt = Module x π / cos (19°31'42" )    (2) f<sub>p</sub> = Single Pitch Error    (3) F<sub>p</sub> = Total Pitch Error

\* For all models APEX also provides Rack without screw-holes. By ordering please change the 2nd last order-code position from "I" to "O". Please also refer to page 14.

# Rack with Helical Teeth

Quality 6 / Carbon Steel  
 Tooth Thickness Tolerance : -22 ~ 0 μm  
 Right-Hand Helical Teeth  
 Teeth Induction Hardened and Ground  
 All Sides Ground

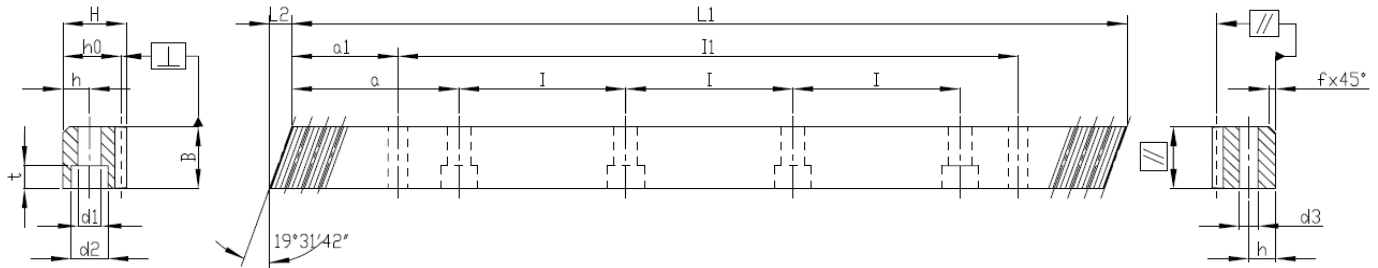

Mn	Pt <sup>(1)</sup>	L1	L2	Teeth No.	B	H	ho	f	a	l	Hole No.	h	d1	d2	t	a1	l1	d3	fp <sup>(2)</sup>	Fp <sup>(3)</sup>	Order Code *
1	3.33334	500.00	5.3	150	15	15	14.0	2	62.5	125	4	6	5	8	5	30.3	439.4	5.7	0.008	0.029	0106R050C10
1	3.33334	1000.00	5.3	300	15	15	14.0	2	62.5	125	8	6	5	8	5	30.3	939.4	5.7	0.008	0.033	0106R100C10
1	3.33334	1500.00	5.3	450	15	15	14.0	2	62.5	125	12	6	5	8	5	30.3	1439.4	5.7	0.008	0.033	0106R150C10
1.5	5.00001	500.00	6.7	100	19	19	17.5	2	62.5	125	4	8	7	11	7	31.7	436.6	5.7	0.008	0.029	1J06R050C10
1.5	5.00001	1000.00	6.7	200	19	19	17.5	2	62.5	125	8	8	7	11	7	31.7	936.6	5.7	0.008	0.034	1J06R100C10
2	6.66668	500.00	8.5	75	24	24	22	2	62.5	125	4	8	7	11	7	31.7	436.6	5.7	0.008	0.029	0206R050C10
2	6.66668	1000.00	8.5	150	24	24	22.0	2	62.5	125	8	8	7	11	7	31.7	936.6	5.7	0.008	0.034	0206R100C10
2	6.66668	1500.00	8.5	225	24	24	22.0	2	62.5	125	12	8	7	11	7	31.7	1436.6	5.7	0.008	0.034	0206R150C10
2	6.66668	2000.00	8.5	300	24	24	22.0	2	62.5	125	16	8	7	11	7	31.7	1936.6	5.7	0.009	0.038	0206R200C10
2.5	8.33335	500.00	10.3	60	29	29	26.5	2	62.5	125	4	9	10	15	9	35.0	430.0	7.7	0.008	0.032	2J06R050C10
2.5	8.33335	1000.00	10.3	120	29	29	26.5	2	62.5	125	8	9	10	15	9	35.0	930.0	7.7	0.009	0.036	2J06R100C10
2.5	8.33335	1500.00	10.3	180	29	29	26.5	2	62.5	125	12	9	10	15	9	35.0	1430.0	7.7	0.009	0.036	2J06R150C10
2.5	8.33335	2000.00	10.3	240	29	29	26.5	2	62.5	125	16	9	10	15	9	35.0	1930.0	7.7	0.010	0.041	2J06R200C10
3	10.00002	500.00	10.3	50	29	29	26.0	2	62.5	125	4	9	10	15	9	35.0	430.0	7.7	0.008	0.032	0306R050C10
3	10.00002	1000.00	10.3	100	29	29	26.0	2	62.5	125	8	9	10	15	9	35.0	930.0	7.7	0.009	0.037	0306R100C10
3	10.00002	1500.00	10.3	150	29	29	26.0	2	62.5	125	12	9	10	15	9	35.0	1430.0	7.7	0.009	0.037	0306R150C10
3	10.00002	2000.00	10.3	200	29	29	26.0	2	62.5	125	16	9	10	15	9	35.0	1930.0	7.7	0.010	0.042	0306R200C10
4	13.33335	506.67	13.8	38	39	39	35.0	3	62.5	125	4	12	10	15	9	33.3	440.1	7.7	0.009	0.034	0406R050C10
4	13.33335	506.67	13.8	38	39	39	35.0	3	62.5	125	4	12	14	20	13	33.3	440.1	11.7	0.009	0.034	0406R050CS0
4	13.33335	1000.00	13.8	75	39	39	35.0	3	62.5	125	8	12	10	15	9	33.3	933.4	7.7	0.010	0.040	0406R100C10
4	13.33335	1000.00	13.8	75	39	39	35.0	3	62.5	125	8	12	14	20	13	33.3	933.4	11.7	0.010	0.040	0406R100CS0
4	13.33335	1506.67	13.8	113	39	39	35.0	3	62.5	125	12	12	14	20	13	33.3	1440.1	11.7	0.010	0.040	0406R150CS0
4	13.33335	2000.00	13.8	150	39	39	35.0	3	62.5	125	16	12	10	15	9	33.3	1933.4	7.7	0.011	0.045	0406R200C10
4	13.33335	2000.00	13.8	150	39	39	35.0	3	62.5	125	16	12	14	20	13	33.3	1933.4	11.7	0.011	0.045	0406R200CS0
5	16.66669	500.00	17.4	30	49	49	34.0	3	62.5	125	4	12	14	20	13	37.5	425.0	11.7	0.009	0.034	0506R050C10
5	16.66669	1000.00	17.4	60	49	49	34.0	3	62.5	125	8	12	14	20	13	37.5	925.0	11.7	0.010	0.040	0506R100C10
5	16.66669	1500.00	17.4	90	49	49	34.0	3	62.5	125	12	12	14	20	13	37.5	1425.0	11.7	0.010	0.040	0506R150C10
5	16.66669	2000.00	17.4	120	49	49	34.0	3	62.5	125	16	12	14	20	13	37.5	1925.0	11.7	0.011	0.045	0506R200C10
6	20.00003	500.00	20.9	25	59	59	43.0	3	62.5	125	4	16	18	26	17	37.5	425.0	15.7	0.009	0.034	0606R050C10
6	20.00003	1000.00	20.9	50	59	59	43.0	3	62.5	125	8	16	18	26	17	37.5	925.0	15.7	0.010	0.040	0606R100C10
6	20.00003	1500.00	20.9	75	59	59	43.0	3	62.5	125	12	16	18	26	17	37.5	1425.0	15.7	0.010	0.040	0606R150C10
6	20.00003	2000.00	20.9	100	59	59	43.0	3	62.5	125	16	16	18	26	17	37.5	1925.0	15.7	0.011	0.045	0606R200C10
8	26.66671	480.00	28.0	18	79	79	71.0	3	60.0	120	4	25	22	33	21	120.0	240.0	19.7	0.011	0.037	0806R050C10
8	26.66671	960.00	28.0	36	79	79	71.0	3	60.0	120	8	25	22	33	21	120.0	720.0	19.7	0.011	0.043	0806R100C10
8	26.66671	1440.00	28.0	54	79	79	71.0	3	60.0	120	12	25	22	33	21	120.0	1200.0	19.7	0.011	0.043	0806R150C10
8	26.66671	1920.00	28.0	72	79	79	71.0	3	60.0	120	16	25	22	33	21	120.0	1680.0	19.7	0.012	0.048	0806R200C10
10	33.33339	1000.00	35.1	30	99	99	89.0	3	62.5	125	8	32	33	48	32	125.0	750.0	19.7	0.011	0.043	1006R100C10
10	33.33339	1500.00	35.1	45	99	99	89.0	3	62.5	125	12	32	33	48	32	125.0	1250.0	19.7	0.011	0.043	1006R150C10
12	40.00006	1000.00	42.6	25	120	120	108.0	3	40.0	125	8	40	39	58	38	102.5	750.0	19.7	0.013	0.046	1206R100C10

(1) Teeth Pitch Pt = Module × π / cos (19°31'42") (2) fp = Single Pitch Error (3) Fp = Total Pitch Error

\* For all models APEX also provides Rack without screw-holes. By ordering please change the 2nd last order-code position from "1" to "0". Please also refer to page 14.

Quality 6M / Carbon Steel  
 Tooth Thickness Tolerance : -22 ~ 0 μm  
 Right-Hand Helical Teeth  
 Teeth Induction Hardened and Ground  
 All Sides Milled

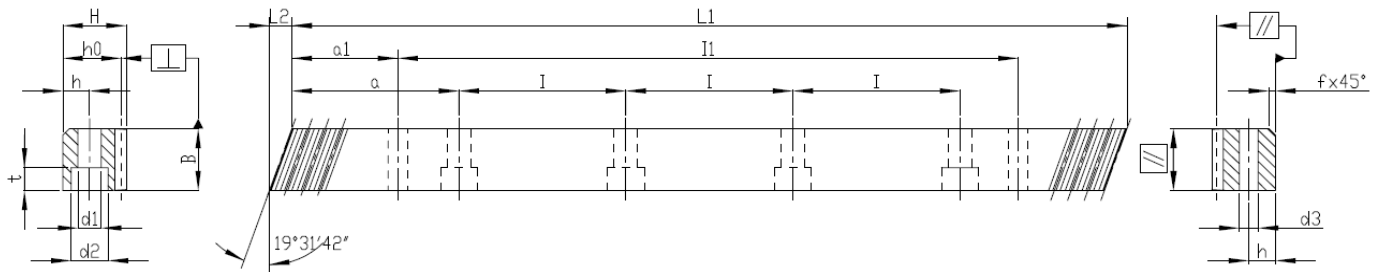

Mn	Pt <sup>(1)</sup>	L1	L2	Teeth No.	B	H	ho	f	a	I	Hole No.	h	d1	d2	t	aI	II	d3	fp <sup>(2)</sup>	Fp <sup>(3)</sup>	Order Code *
2	6.66668	500	8.5	75	24	24	22	2	62.5	125	4	8	7	11	7	31.7	436.6	5.7	0.008	0.029	026MR050C10
2	6.66668	1000	8.5	150	24	24	22	2	62.5	125	8	8	7	11	7	31.7	936.6	5.7	0.008	0.034	026MR100C10
3	10.00002	500	10.3	50	29	29	26	2	62.5	125	4	9	10	15	9	35	430	7.7	0.008	0.032	036MR050C10
3	10.00002	1000	10.3	100	29	29	26	2	62.5	125	8	9	10	15	9	35	930	7.7	0.009	0.037	036MR100C10
4	13.33335	506.67	13.8	38	39	39	35	3	62.5	125	4	12	10	15	9	33.3	440.1	7.7	0.009	0.034	046MR050C10
4	13.33335	506.67	13.8	38	39	39	35	3	62.5	125	4	12	14	20	13	33.3	440.1	11.7	0.009	0.034	046MR050CS0
4	13.33335	1000	13.8	75	39	39	35	3	62.5	125	8	12	10	15	9	33.3	933.4	7.7	0.01	0.04	046MR100C10
4	13.33335	1000	13.8	75	39	39	35	3	62.5	125	8	12	14	20	13	33.3	933.4	11.7	0.01	0.04	046MR100CS0
5	16.66669	500	17.4	30	49	39	34	3	62.5	125	4	12	14	20	13	37.5	425	11.7	0.009	0.034	056MR050C10
5	16.66669	1000	17.4	60	49	39	34	3	62.5	125	8	12	14	20	13	37.5	925	11.7	0.01	0.04	056MR100C10
6	20.00003	500	20.9	25	59	49	43	3	62.5	125	4	16	18	26	17	37.5	425	15.7	0.009	0.034	066MR050C10
6	20.00003	1000	20.9	50	59	49	43	3	62.5	125	8	16	18	26	17	37.5	925	15.7	0.01	0.04	066MR100C10
8	26.66671	960	28	36	79	79	71	3	60	120	8	25	22	33	21	120	720	19.7	0.011	0.043	086MR100C10
10	33.33339	1000	35.1	30	99	99	89	3	62.5	125	8	32	33	48	32	125	750	19.7	0.011	0.043	106MR100C10

(1) Teeth Pitch Pt = Module x π / cos (19°31'42")    (2) fp = Single Pitch Error    (3) Fp = Total Pitch Error

\* For all models APEX also provides Rack without screw-holes. By ordering please change the 2nd last order-code position from "1" to "0". Please also refer to page 14.

# Rack with Helical Teeth

Quality 8H / Q&T Alloy Steel  
 Material Quenched and Tempered  
 Tooth Thickness Tolerance : -48 ~ 0 μm  
 Right-Hand Helical Teeth  
 Teeth Milled / All Sides Milled

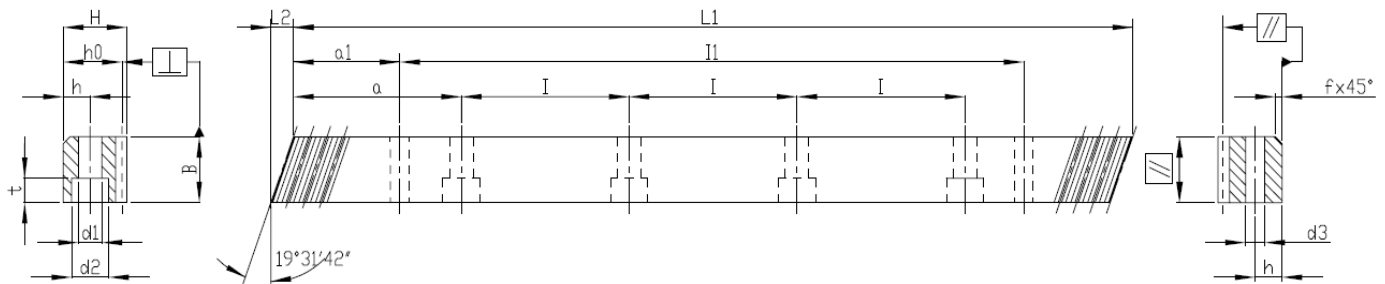

Mn	P <sub>t</sub> <sup>(1)</sup>	L1	L2	Teeth No.	B	H	h <sub>0</sub>	f	a	l	Hole No.	h	d1	d2	t	a1	l1	d3	f <sub>p</sub> <sup>(2)</sup>	F <sub>p</sub> <sup>(3)</sup>	Order Code *
2	6.66668	1000	8.9	150	25	24	22	2	62.5	125	8	8	7	11	7	31.7	936.6	5.7	0.016	0.066	028HR100Q10
2	6.66668	2000	8.9	300	25	24	22	2	62.5	125	16	8	7	11	7	31.7	1936.6	5.7	0.018	0.074	028HR200Q10
3	10.00002	1000	10.6	100	30	29	26	2	62.5	125	8	9	10	15	9	35	930	7.7	0.018	0.072	038HR100Q10
3	10.00002	2000	10.6	200	30	29	26	2	62.5	125	16	9	10	15	9	35	1930	7.7	0.019	0.081	038HR200Q10
4	13.33335	1000	14.2	75	40	39	35	3	62.5	125	8	12	10	15	9	33.3	933.4	7.7	0.019	0.078	048HR100Q10
4	13.33335	2000	14.2	150	40	39	35	3	62.5	125	16	12	10	15	9	33.3	1933.4	7.7	0.021	0.088	048HR200Q10

(1) Teeth Pitch  $P_t = \text{Module} \times \pi / \cos(19^\circ 31' 42'')$     (2)  $f_p$  = Single Pitch Error    (3)  $F_p$  = Total Pitch Error

\* For all models APEX also provides Rack without screw-holes. By ordering please change the 2nd last order-code position from "1" to "0". Please also refer to page 14.

Especially for the application without back-support.

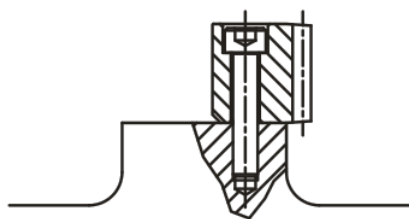

Without alignment / back-support

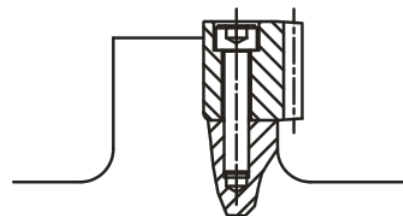

With alignment / back-support

Quality 8 / Carbon Steel  
 Tooth Thickness Tolerance : -48 ~ 0 μm  
 Right-Hand Helical Teeth  
 Material Normalized  
 Teeth Milled and all Sides Milled

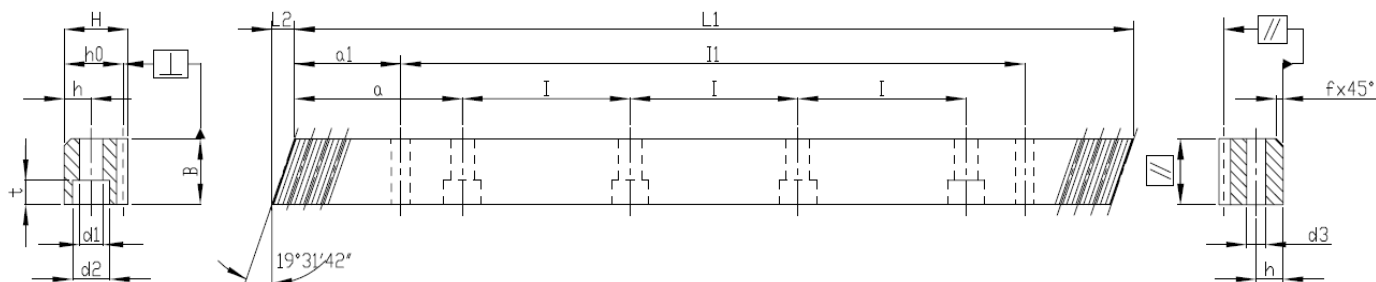

Mn	Pt <sup>(1)</sup>	L1	L2	Teeth No.	B	H	ho	f	a	I	Hole No.	h	d1	d2	t	a1	l1	d3	fp <sup>(2)</sup>	Fp <sup>(3)</sup>	Order Code*
1.5	5.00001	500.00	6.0	100	17	17	15.5	2	62.5	125	4	6	6	10	6	31.7	436.6	5.7	0.015	0.057	IJ08R050C10
1.5	5.00001	1000.00	6.0	200	17	17	15.5	2	62.5	125	8	6	6	10	6	31.7	936.6	5.7	0.016	0.066	IJ08R100C10
1.5	5.00001	1500.00	6.0	300	17	17	15.5	2	62.5	125	12	6	6	10	6	31.7	1436.6	5.7	0.016	0.066	IJ08R150C10
1.5	5.00001	2000.00	6.0	400	17	17	15.5	2	62.5	125	16	6	6	10	6	31.7	1936.6	5.7	0.018	0.074	IJ08R200C10
2	6.66668	500.00	9.2	75	26	24	22.0	2	62.5	125	4	8	7	11	7	31.7	436.6	5.7	0.015	0.057	O208R050C10
2	6.66668	1500.00	9.2	225	26	24	22.0	2	62.5	125	12	8	7	11	7	31.7	1436.6	5.7	0.016	0.066	O208R150C10
2	6.66668	1000.00	9.2	150	26	24	22.0	2	62.5	125	8	8	7	11	7	31.7	936.6	5.7	0.016	0.066	O208R100C10
2	6.66668	2000.00	9.2	300	26	24	22.0	2	62.5	125	16	8	7	11	7	31.7	1936.6	5.7	0.018	0.074	O208R200C10
2.5	8.33335	500.00	10.6	60	30	29	26.5	2	62.5	125	4	9	10	15	9	35.0	430.0	7.7	0.016	0.062	2J08R050C10
2.5	8.33335	1000.00	10.6	120	30	29	26.5	2	62.5	125	8	9	10	15	9	35.0	930.0	7.7	0.018	0.072	2J08R100C10
2.5	8.33335	1500.00	10.6	180	30	29	26.5	2	62.5	125	12	9	10	15	9	35.0	1430.0	7.7	0.018	0.072	2J08R150C10
2.5	8.33335	2000.00	10.6	240	30	29	26.5	2	62.5	125	16	9	10	15	9	35.0	1930.0	7.7	0.019	0.081	2J08R200C10
3	10.00002	500.00	11.0	50	31	29	26.0	2	62.5	125	4	9	10	15	9	35.0	430.0	7.7	0.016	0.063	O308R050C10
3	10.00002	1500.00	11.0	150	31	29	26.0	2	62.5	125	12	9	10	15	9	35.0	1430.0	7.7	0.018	0.072	O308R150C10
3	10.00002	1000.00	11.0	100	31	29	26.0	2	62.5	125	8	9	10	15	9	35.0	930.0	7.7	0.018	0.072	O308R100C10
3	10.00002	2000.00	11.0	200	31	29	26.0	2	62.5	125	16	9	10	15	9	35.0	1930.0	7.7	0.019	0.081	O308R200C10
4	13.33335	506.67	14.5	38	41	39	35.0	3	62.5	125	4	12	10	15	9	33.3	440.1	7.7	0.018	0.068	O408R050C10
4	13.33335	1000.00	14.5	75	41	39	35.0	3	62.5	125	8	12	10	15	9	33.3	933.4	7.7	0.019	0.078	O408R100C10
4	13.33335	1000.00	14.5	75	41	39	35.0	3	62.5	125	8	12	14	20	13	33.3	933.4	11.7	0.019	0.078	O408R100CS0
4	13.33335	1506.67	14.5	113	41	39	35.0	3	62.5	125	12	12	14	20	13	33.3	1440.1	11.7	0.019	0.078	O408R150CS0
4	13.33335	2000.00	14.5	150	41	39	35.0	3	62.5	125	16	12	10	15	9	33.3	1933.4	7.7	0.021	0.088	O408R200C10
4	13.33335	2000.00	14.5	150	41	39	35.0	3	62.5	125	16	12	14	20	13	33.3	1933.4	11.7	0.021	0.088	O408R200CS0
5	16.66669	500.00	17.7	30	50	39	34.0	3	62.5	125	4	12	14	20	13	37.5	425.0	11.7	0.018	0.068	O508R050C10
5	16.66669	1000.00	17.7	60	50	39	34.0	3	62.5	125	8	12	14	20	13	37.5	925.0	11.7	0.019	0.078	O508R100C10
5	16.66669	2000.00	17.7	120	50	39	34.0	3	62.5	125	16	12	14	20	13	37.5	1925.0	11.7	0.021	0.088	O508R200C10
6	20.00003	500.00	21.3	25	60	49	43.0	3	62.5	125	4	16	18	26	17	37.5	425.0	15.7	0.018	0.068	O608R050C10
6	20.00003	1000.00	21.3	50	60	49	43.0	3	62.5	125	8	16	18	26	17	37.5	925.0	15.7	0.019	0.078	O608R100C10
6	20.00003	2000.00	21.3	100	60	49	43.0	3	62.5	125	16	16	18	26	17	37.5	1925.0	15.7	0.021	0.088	O608R200C10
8	26.66671	480.00	28.7	18	81	79	71.0	3	60.0	120	4	25	22	33	21	120.0	240.0	19.7	0.021	0.073	O808R050C10
8	26.66671	960.00	28.7	36	81	79	71.0	3	60.0	120	8	25	22	33	21	120.0	720.0	19.7	0.022	0.084	O808R100C10
8	26.66671	1920.00	28.7	72	81	79	71.0	3	60.0	120	16	25	22	33	21	120.0	1680.0	19.7	0.024	0.095	O808R200C10
10	33.33339	1000.00	35.5	30	100	99	89.0	3	62.5	125	8	32	33	48	32	125.0	750.0	19.7	0.022	0.084	I008R100C10
12	40.00006	1000.00	42.6	25	120	120	108	3	40.0	125	8	40	39	58	38	102.5	750.0	19.7	0.026	0.090	I208R100C10

(1) Teeth Pitch Pt = Module x π / cos (19°31'42") (2) fp = Single Pitch Error (3) Fp = Total Pitch Error

\* For all models APEX also provides Rack without screw-holes. By ordering please change the 2nd last order-code position from "I" to "O". Please also refer to page 14.

# Rack with Helical Teeth

Quality 10 / Carbon Steel  
 Tooth Thickness Tolerance : -90 ~ 0 μm  
 Right-Hand Helical Teeth  
 Teeth Milled and Induction Hardened  
 All Sides Milled

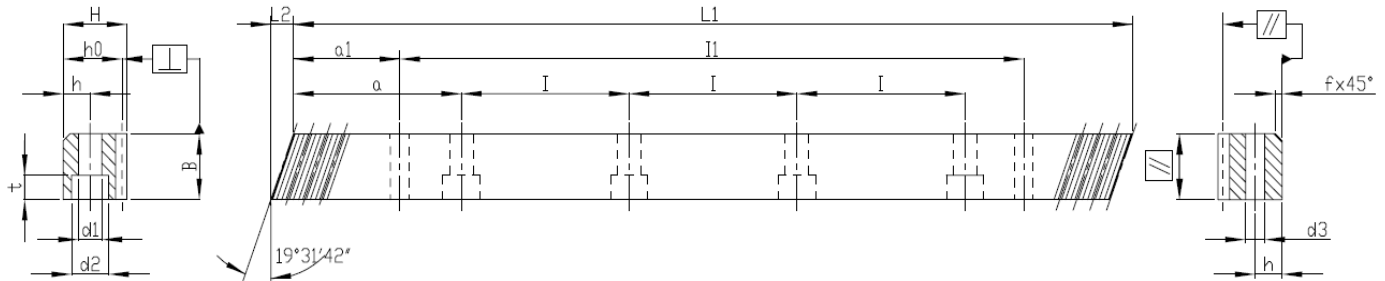

Mn	P <sub>t</sub> <sup>(1)</sup>	L1	L2	Teeth No.	B	H	h <sub>0</sub>	f	a	I	Hole No.	h	d1	d2	t	aI	II	d3	f <sub>p</sub> <sup>(2)</sup>	F <sub>p</sub> <sup>(3)</sup>	Order Code *
1.5	5.00001	500.00	6	100	17	17	15.5	2	62.5	125	4	6	6	10	6	31.7	436.6	5.7	0.034	0.128	IJ10R050C10
1.5	5.00001	1000.00	6	200	17	17	15.5	2	62.5	125	8	6	6	10	6	31.7	936.6	5.7	0.037	0.148	IJ10R100C10
1.5	5.00001	1500.00	6	300	17	17	15.5	2	62.5	125	12	6	6	10	6	31.7	1436.6	5.7	0.037	0.148	IJ10R150C10
1.5	5.00001	2000.00	6	400	17	17	15.5	2	62.5	125	16	6	6	10	6	31.7	1936.6	5.7	0.041	0.167	IJ10R200C10
2	6.66668	500.00	9.2	75	26	24	22.0	2	62.5	125	4	8	7	11	7	31.7	436.6	5.7	0.034	0.128	0210R050C10
2	6.66668	1500.00	9.2	225	26	24	22.0	2	62.5	125	12	8	7	11	7	31.7	1436.6	5.7	0.037	0.148	0210R150C10
2	6.66668	1000.00	9.2	150	26	24	22.0	2	62.5	125	8	8	7	11	7	31.7	936.6	5.7	0.037	0.148	0210R100C10
2	6.66668	2000.00	9.2	300	26	24	22.0	2	62.5	125	16	8	7	11	7	31.7	1936.6	5.7	0.041	0.167	0210R200C10
2.5	8.33335	500.00	10.6	60	30	29	26.5	2	62.5	125	4	9	10	15	9	35.0	430.0	7.7	0.036	0.139	2J10R050C10
2.5	8.33335	1000.00	10.6	120	30	29	26.5	2	62.5	125	8	9	10	15	9	35.0	930.0	7.7	0.039	0.160	2J10R100C10
2.5	8.33335	1500.00	10.6	180	30	29	26.5	2	62.5	125	12	9	10	15	9	35.0	1430.0	7.7	0.039	0.160	2J10R150C10
2.5	8.33335	2000.00	10.6	240	30	29	26.5	2	62.5	125	16	9	10	15	9	35.0	1930.0	7.7	0.043	0.181	2J10R200C10
3	10.00002	500.00	11.0	50	31	29	26.0	2	62.5	125	4	9	10	15	9	35.0	430.0	7.7	0.036	0.140	0310R050C10
3	10.00002	1500.00	11.0	150	31	29	26.0	2	62.5	125	12	9	10	15	9	35.0	1430.0	7.7	0.039	0.162	0310R150C10
3	10.00002	1000.00	11.0	100	31	29	26.0	2	62.5	125	8	9	10	15	9	35.0	930.0	7.7	0.039	0.162	0310R100C10
3	10.00002	2000.00	11.0	200	31	29	26.0	2	62.5	125	16	9	10	15	9	35.0	1930.0	7.7	0.043	0.182	0310R200C10
4	13.33335	506.67	14.5	38	41	39	35.0	3	62.5	125	4	12	10	15	9	33.3	440.1	7.7	0.040	0.151	0410R050C10
4	13.33335	1000.00	14.5	75	41	39	35.0	3	62.5	125	8	12	10	15	9	33.3	933.4	7.7	0.043	0.175	0410R100C10
4	13.33335	1000.00	14.5	75	41	39	35.0	3	62.5	125	8	12	14	20	13	33.3	933.4	11.7	0.043	0.175	0410R100CS0
4	13.33335	1506.67	14.5	113	41	39	35.0	3	62.5	125	12	12	14	20	13	33.3	1440.1	11.7	0.043	0.175	0410R150CS0
4	13.33335	2000.00	14.5	150	41	39	35.0	3	62.5	125	16	12	10	15	9	33.3	1933.4	7.7	0.047	0.197	0410R200C10
4	13.33335	2000.00	14.5	150	41	39	35.0	3	62.5	125	16	12	14	20	13	33.3	1933.4	11.7	0.047	0.197	0410R200CS0
5	16.66669	500.00	17.7	30	50	39	34.0	3	62.5	125	4	12	14	20	13	37.5	425.0	11.7	0.040	0.151	0510R050C10
5	16.66669	1000.00	17.7	60	50	39	34.0	3	62.5	125	8	12	14	20	13	37.5	925.0	11.7	0.043	0.175	0510R100C10
5	16.66669	2000.00	17.7	120	50	39	34.0	3	62.5	125	16	12	14	20	13	37.5	1925.0	11.7	0.047	0.197	0510R200C10
6	20.00003	500.00	21.3	25	60	49	43.0	3	62.5	125	4	16	18	26	17	37.5	425.0	15.7	0.040	0.151	0610R050C10
6	20.00003	1000.00	21.3	50	60	49	43.0	3	62.5	125	8	16	18	26	17	37.5	925.0	15.7	0.043	0.175	0610R100C10
6	20.00003	2000.00	21.3	100	60	49	43.0	3	62.5	125	16	16	18	26	17	37.5	1925.0	15.7	0.047	0.197	0610R200C10
8	26.66671	480.00	28.7	18	81	79	71.0	3	60.0	120	4	25	22	33	21	120.0	240.0	19.7	0.046	0.163	0810R050C10
8	26.66671	960.00	28.7	36	81	79	71.0	3	60.0	120	8	25	22	33	21	120.0	720.0	19.7	0.049	0.188	0810R100C10
8	26.66671	1920.00	28.7	72	81	79	71.0	3	60.0	120	16	25	22	33	21	120.0	1680.0	19.7	0.053	0.212	0810R200C10
10	33.33339	1000.00	35.5	30	100	99	89.0	3	62.5	125	8	32	33	48	32	125.0	750.0	19.7	0.049	0.188	1010R100C10
12	40.00006	1000.00	42.6	25	120	120	108	3	40.0	125	8	40	39	58	38	102.5	750.0	19.7	0.059	0.202	1210R100C10

(1) Teeth Pitch Pt = Module x π / cos (19°31'42") (2) f<sub>p</sub> = Single Pitch Error (3) F<sub>p</sub> = Total Pitch Error \* Refer to Page 21



# Rack with Helical Teeth

( with Linear-Guide Interface, 90° Type )

Quality 6 / Carbon Steel  
 Tooth Thickness Tolerance : -22 ~ 0 μm  
 Right-Hand Helical Teeth  
 Teeth Induction Hardened and Ground  
 All Sides Ground

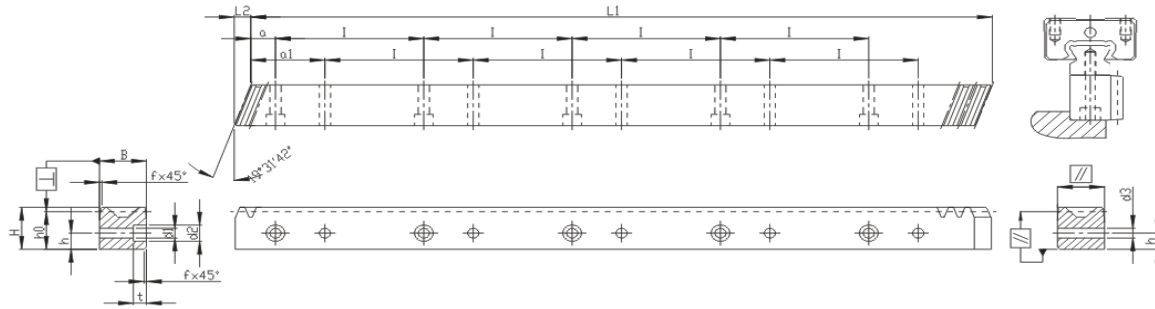

Mn	Pt <sup>(1)</sup>	L1	L2	Teeth No.	B	H	ho	f	a	l	Hole No.	h	d1	d2	t	a1	d3	fp <sup>(2)</sup>	Fp <sup>(3)</sup>	Order Code
2	6.66668	480	6.7	72	19	19.50	17.50	1	10	60	8	7.5	4.5	7.5	5.3	30	4.5	0.008	0.029	0206R050C10A1
2	6.66668	960	6.7	144	19	19.50	17.50	1	10	60	16	7.5	4.5	7.5	5.3	30	4.5	0.008	0.034	0206R100C10A1
2	6.66668	480	8.5	72	24	24.50	22.50	1	10	60	8	10.0	6.0	9.5	8.5	30	6.0	0.008	0.029	0206R050CS0A1
2	6.66668	960	8.5	144	24	24.50	22.50	1	10	60	16	10.0	6.0	9.5	8.5	30	6.0	0.008	0.034	0206R100CS0A1
3	10.00002	480	10.3	48	29	29.75	26.75	2	10	60	8	11.5	7.0	11.0	9.0	30	7.0	0.008	0.032	0306R050C10A1
3	10.00002	960	10.3	96	29	29.75	26.75	2	10	60	16	11.5	7.0	11.0	9.0	30	7.0	0.009	0.037	0306R100C10A1
4	13.33335	480	13.8	36	39	39.75	35.75	2	20	80	6	14.0	10.0	15.0	9.0	40	10.0	0.009	0.034	0406R050C10A1
4	13.33335	960	13.8	72	39	39.75	35.75	2	20	80	12	14.0	10.0	15.0	9.0	40	10.0	0.010	0.040	0406R100C10A1
4	13.33335	480	13.8	36	39	48.75	44.75	2	20	80	6	17.0	10.0	15.0	9.0	40	10.0	0.009	0.034	0406R050CS0A1
4	13.33335	960	13.8	72	39	48.75	44.75	2	20	80	12	17.0	10.0	15.0	9.0	40	10.0	0.010	0.040	0406R100CS0A1
4	13.33335	840	17.4	63	49	58.00	54.00	2	30	105	8	22.5	14.0	20.0	13.0	60	14.0	0.009	0.034	0406R084CS0A1

Quality 8 / Carbon Steel  
 Tooth Thickness Tolerance : -48 ~ 0 μm  
 Right-Hand Helical Teeth  
 Material Normalized  
 Teeth Milled and all Sides Milled

Mn	Pt <sup>(1)</sup>	L1	L2	Teeth No.	B	H	ho	f	a	l	Hole No.	h	d1	d2	t	a1	d3	fp <sup>(2)</sup>	Fp <sup>(3)</sup>	Order Code
2	6.66668	1920	7.1	288	20	19.50	17.50	1	10	60	32	7.5	4.5	7.5	5.3	30	4.5	0.018	0.074	0208R200C10A1
2	6.66668	1920	8.9	288	25	24.50	22.50	1	10	60	32	10.0	6	9.5	8.5	30	6.0	0.018	0.074	0208R200CS0A1
3	10.00002	1920	10.6	192	30	29.75	26.75	2	10	60	32	11.5	7	11.0	9.0	30	7.0	0.019	0.081	0308R200C10A1
4	13.33335	1920	14.2	144	40	39.75	35.75	2	20	80	24	14.0	10	15.0	9.0	40	10.0	0.021	0.088	0408R200C10A1
4	13.33335	1920	14.5	144	41	48.75	44.75	2	20	80	24	17.0	10	15.0	9.0	40	10.0	0.021	0.088	0408R200CS0A1

(1) Teeth Pitch Pt = Module x π / cos (19°31'42" )    (2) fp = Single Pitch Error    (3) Fp = Total Pitch Error

# Rack with Helical Teeth

( with Linear-Guide Interface, 180° Type )

Quality 6 / Carbon Steel  
 Tooth Thickness Tolerance : -22 ~ 0 μm  
 Right-Hand Helical Teeth  
 Teeth Induction Hardened and Ground  
 All Sides Ground

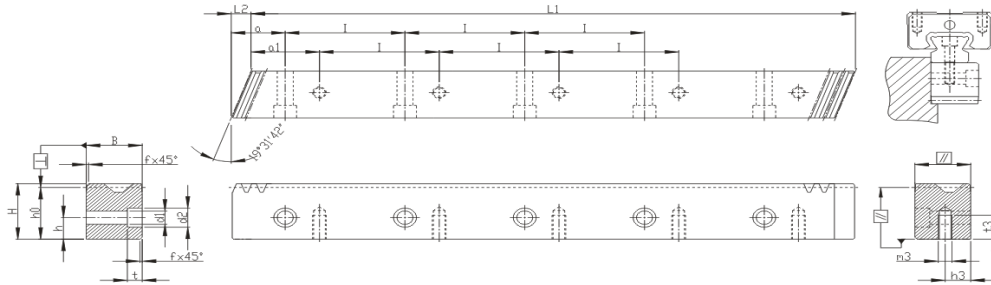

Mn	P <sub>t</sub> <sup>(1)</sup>	L1	L2	Teeth No.	B	H	ho	f	a	l	Hole No.	h	d1	d2	t	a1	m3	h3	t3	f <sub>p</sub> <sup>(2)</sup>	F <sub>p</sub> <sup>(3)</sup>	Order Code
2	6.66668	960	6.7	144	19	19.50	17.50	1	10	60	16	7.5	6	9.5	6	30	M4	7.5	8.0	0.008	0.034	0206R100C10A2
2	6.66668	960	8.5	144	24	24.50	22.50	1	10	60	16	10.0	7	11.0	7	30	M5	10.0	11.0	0.008	0.034	0206R100CS0A2
3	10.00002	960	10.3	96	29	29.75	26.75	2	10	60	16	11.5	10	15.0	9	30	M6	11.5	13.5	0.009	0.037	0306R100C10A2
4	13.33335	960	13.8	72	39	39.75	35.75	2	20	80	12	14.0	12	18.0	12	40	M8	14.0	16.0	0.010	0.040	0406R100C10A2
4	13.33335	960	13.8	72	39	48.75	44.75	2	20	80	12	17.0	12	18.0	12	40	M8	17.0	16.0	0.010	0.040	0406R100CS0A2
4	13.33335	840	17.4	63	49	58.00	54.00	2	30	105	8	22.5	14	20.0	13	60	M12	22.5	25.0	0.009	0.034	0406R084CS0A2

Quality 8 / Carbon Steel  
 Tooth Thickness Tolerance : -48 ~ 0 μm  
 Right-Hand Helical Teeth  
 Material Normalized  
 Teeth Milled and all Sides Milled

Mn	P <sub>t</sub> <sup>(1)</sup>	L1	L2	Teeth No.	B	H	ho	f	a	l	Hole No.	h	d1	d2	t	a1	m3	h3	T3	f <sub>p</sub> <sup>(2)</sup>	F <sub>p</sub> <sup>(3)</sup>	Order Code
2	6.66668	1920	7.1	288	20	19.50	17.50	1	10	60	32	7.5	6	9.5	6	30	M4	7.5	8.0	0.018	0.074	0208R200C10A2
2	6.66668	1920	8.9	288	25	24.50	22.50	1	10	60	32	10.0	7	11.0	7	30	M5	10.0	11.0	0.018	0.074	0208R200CS0A2
3	10.00002	1920	10.6	192	30	29.75	26.75	2	10	60	32	11.5	10	15.0	9	30	M6	11.5	13.5	0.019	0.081	0308R200C10A2
4	13.33335	1920	14.2	144	40	39.75	35.75	2	20	80	24	14.0	12	18.0	12	40	M8	14.0	16.0	0.021	0.088	0408R200C10A2

(1) Teeth Pitch Pt = Module x π / cos (19°31'42" )    (2) fp = Single Pitch Error    (3) Fp = Total Pitch Error

# APEX High Precision Pinion

## APEX Pinion Series

A : Curvic Plate / Page 28

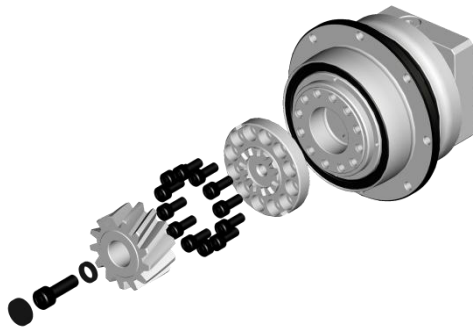

B : Welded Plate / Page 33



C : Teeth Plate / Page 39

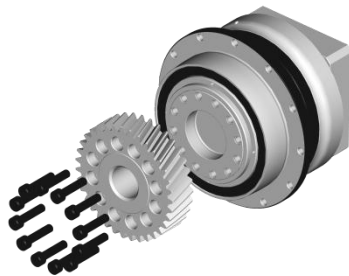

Teeth Plate with Flange / Page 40

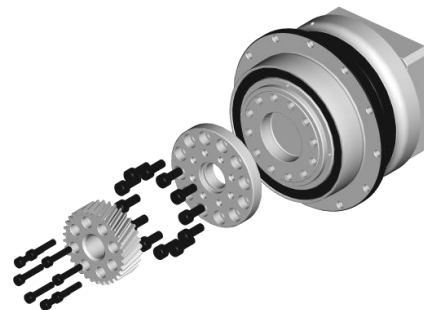

D : DIN 5480 / Page 44

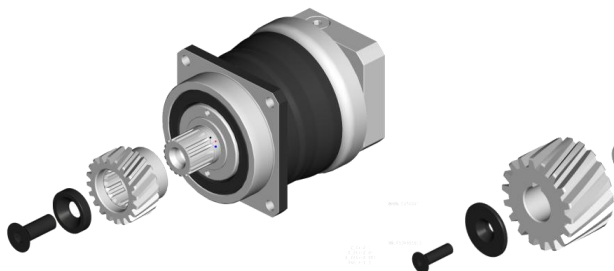

E , F : Keyway without Shrink-Disc / Page 46

F : Keyway with Shrink-Disc / Page 48

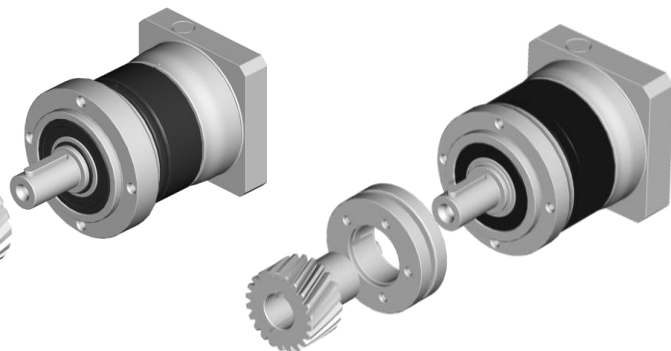

# APEX Pinion Curvic Plate

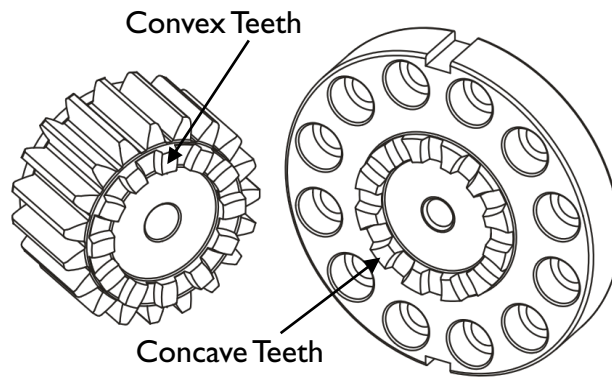

## Advantages of Curvic Coupling

- All-Teeth-Coupling between pinion and gearbox
  - Zero backlash
  - Automatic concentricity
  - High torque transmission
- The Round-Out of the gearbox-pinion-set can be adjusted by switching the curvic positions.
- Quick assembly and disassembly or replacement
- More suitable pinion teeth-no. can be chosen, without interference with screwing.

Step 1.

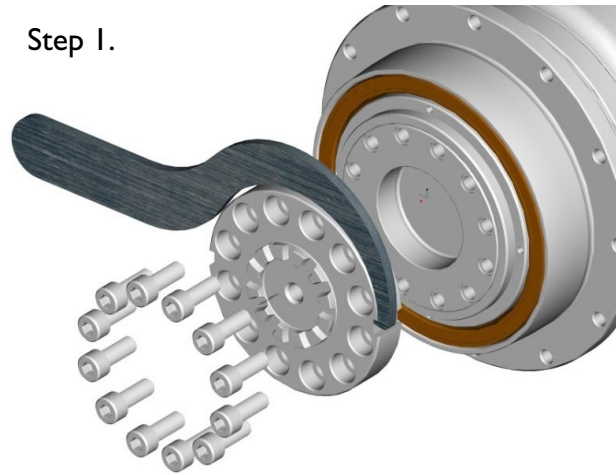

Step 2.

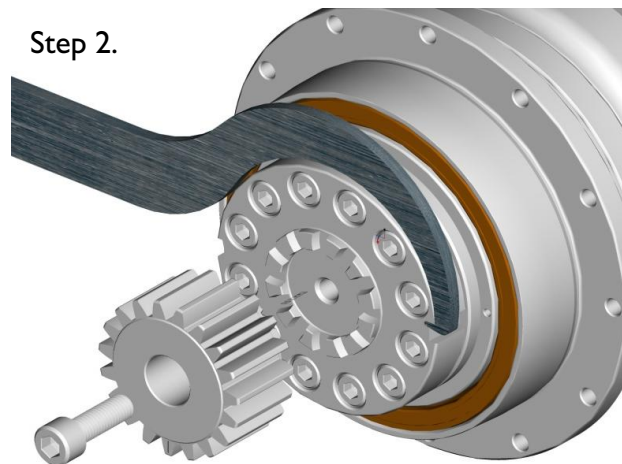

# Pinion Order Code

**Example : A 02 L 14 B 031**

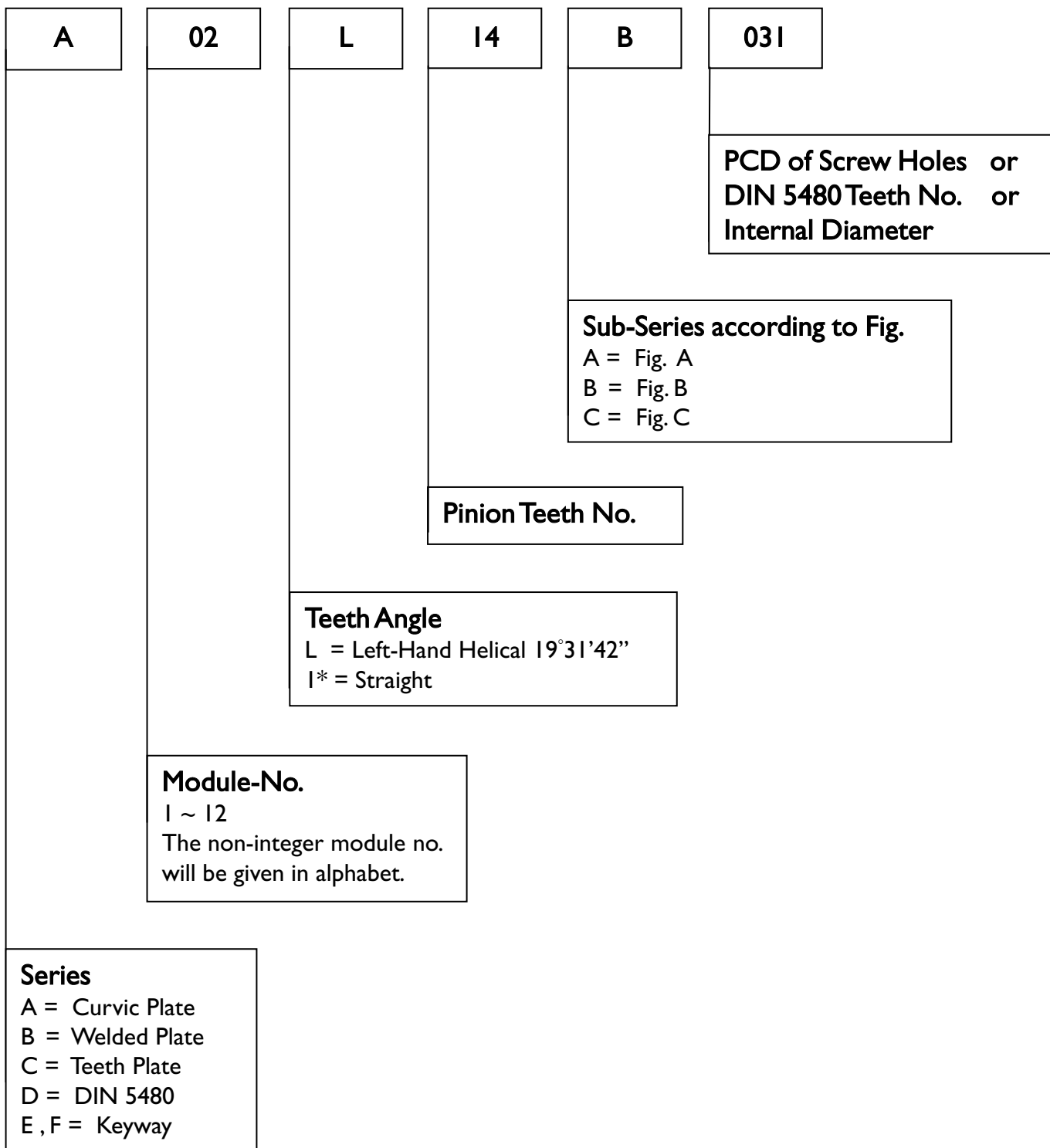

\* I = "one"

# Pinion with Helical Teeth

( Interface : Curvic Plate / EN ISO 9409-I-A )

Quality DIN 4 / Alloy Steel  
Tooth Thickness Tolerance : e24  
Left-Hand Helical Teeth  
Case-Hardened and Teeth Ground

## Bolt Circle Ø31.5

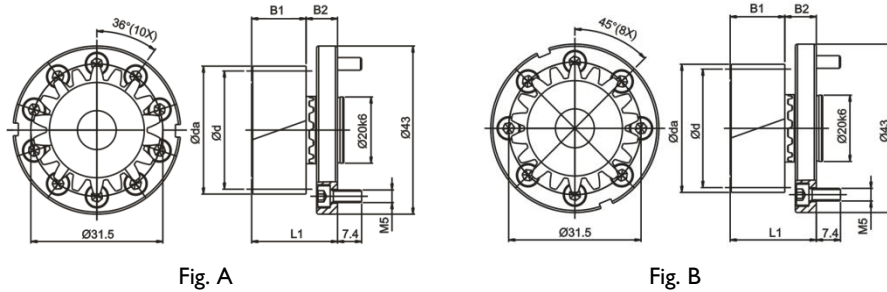

Fig. A

Fig. B

Mn.	z <sup>(1)</sup>	x <sup>(2)</sup>	da <sup>(3)</sup>	d <sup>(4)</sup>	dw <sup>(5)</sup>	B1	B2	L1	L <sup>(6)</sup>	Fig	Order Code	
											Set	Pinion only
2	17	0.441	41.84	36.075	37.84	26	15	41	113.333	A	A02L17A03I	A02L17
										B	A02L17B03I	

## Bolt Circle Ø50

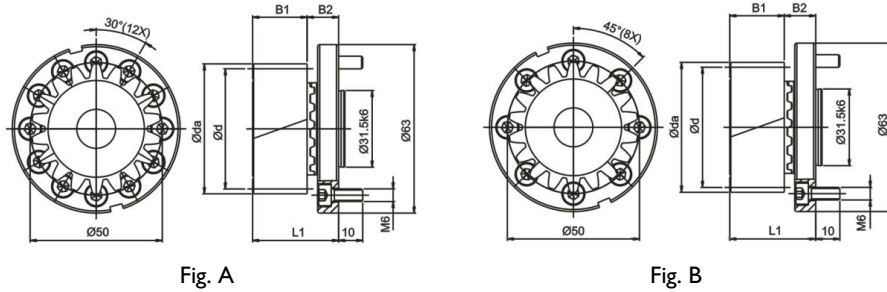

Fig. A

Fig. B

Mn.	z <sup>(1)</sup>	x <sup>(2)</sup>	da <sup>(3)</sup>	d <sup>(4)</sup>	dw <sup>(5)</sup>	B1	B2	L1	L <sup>(6)</sup>	Fig	Order Code	
											Set	Pinion only
2	20	0.390	48.00	42.441	44.00	26	15	41	133.334	A	A02L20A050	A02L20
										B	A02L20B050	
3	17	0.441	62.76	54.113	56.76	31	15	46	170.000	A	A03L17A050	A03L17
										B	A03L17B050	

## Bolt Circle Ø63

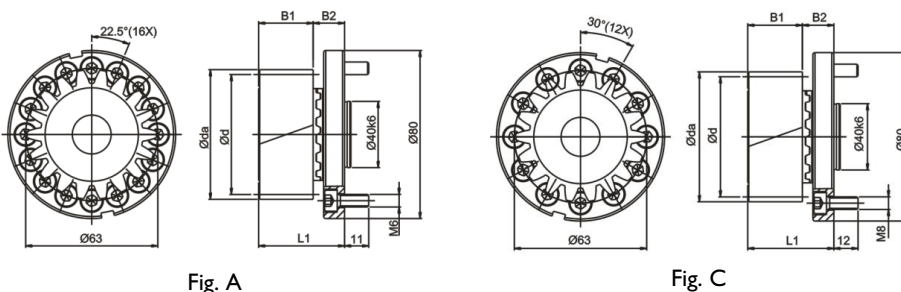

Fig. A

Fig. C

Mn.	z <sup>(1)</sup>	x <sup>(2)</sup>	da <sup>(3)</sup>	d <sup>(4)</sup>	dw <sup>(5)</sup>	B1	B2	L1	L <sup>(6)</sup>	Fig	Order Code	
											Set	Pinion only
2	20	0.390	48	42.441	44	26	15.0	41.0	133.334	A	A02L20A063	A02L20
										C	A02L20C063	
3	20	0.390	72	63.662	66	31	15.0	46.0	200.000	A	A03L20A063	A03L20
										C	A03L20C063	

(1) Number of teeth (2) Profile modification factor (3) Diameter of addendum circle (4) Pitch circle diameter  
(5) Working pitch circle diameter (6) Pitch circle length  $L = \pi \times d$

Quality DIN 4 / Alloy Steel  
 Tooth Thickness Tolerance : e24  
 Left-Hand Helical Teeth  
 Case-Hardened and Teeth Ground

Bolt Circle Ø80

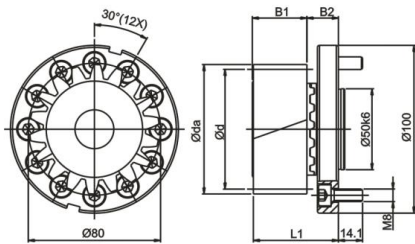

Fig. A

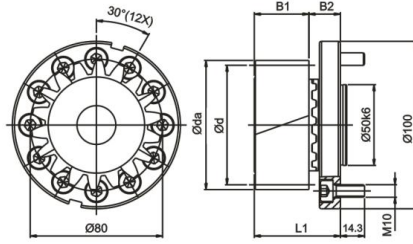

Fig. C

Mn.	z <sup>(1)</sup>	x <sup>(2)</sup>	da <sup>(3)</sup>	d <sup>(4)</sup>	dw <sup>(5)</sup>	B1	B2	L1	L <sup>(6)</sup>	Fig	Order Code	
											Set	Pinion only
3	18	0.118	64	57.296	58	31	21.5	52.5	180.000	A	A03L18A080	A03L18
										C	A03L18C080	
	20	0.390	72	63.662	66	31	21.5	52.5	200.000	A	A03L20A080	A03L20
										C	A03L20C080	
4	19	0.410	91.92	80.639	83.92	41	21.5	62.5	253.335	A	A04L19A080	A04L19
										C	A04L19C080	

Bolt Circle Ø125

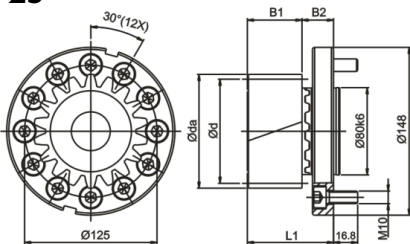

Fig. A

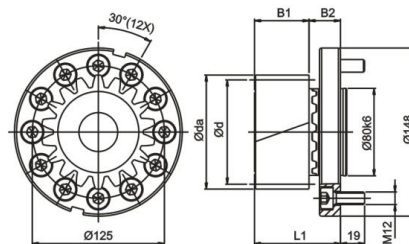

Fig. C

Mn.	z <sup>(1)</sup>	x <sup>(2)</sup>	da <sup>(3)</sup>	d <sup>(4)</sup>	dw <sup>(5)</sup>	B1	B2	L1	L <sup>(6)</sup>	Fig	Order Code	
											Set	Pinion only
4	18	0.638	89.5	76.394	81.5	41	29	70	240.000	A	A04L18A125	A04L18
										C	A04L18C125	
	20	0.190	94.4	84.883	86.4	41	29	70	266.667	A	A04L20A125	A04L20
										C	A04L20C125	
5	19	0.400	114.8	100.798	104.8	51	29	80	316.666	A	A05L19A125	A05L19
										C	A05L19C125	

Bolt Circle Ø140 / Ø145

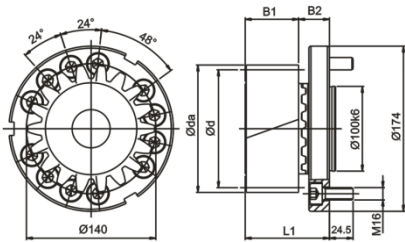

Fig. A

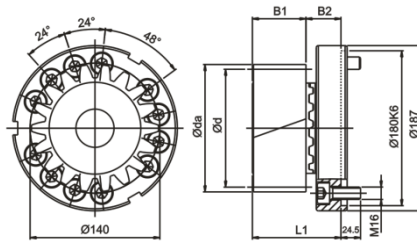

Fig. B

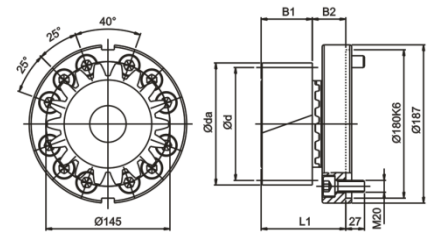

Fig. C

Mn.	z <sup>(1)</sup>	x <sup>(2)</sup>	da <sup>(3)</sup>	d <sup>(4)</sup>	dw <sup>(5)</sup>	B1	B2	L1	L <sup>(6)</sup>	Fig	Order Code	
											Set	Pinion only
5	18	0.251	108.0	95.493	98.0	51	38	89	300.000	A	A05L18A140	A05L18
										B	A05L18B140	
										C	A05L18C145	
	19	0.400	114.8	100.798	104.8	51	38	89	316.667	A	A05L19A140	A05L19
										B	A05L19B140	
										C	A05L19C145	
6	19	0.404	137.8	120.958	125.8	61	38	99	380.000	A	A06L19A140	A06L19
										B	A06L19B140	
										C	A06L19C145	

# Pinion with Helical Teeth

( Interface : Curvic Plate / EN ISO 9409-1-A )

Quality DIN 4 / Alloy Steel  
 Tooth Thickness Tolerance : e24  
 Left-Hand Helical Teeth  
 Case-Hardened and Teeth Ground

Bolt Circle  $\varnothing 160$  /  $\varnothing 166$

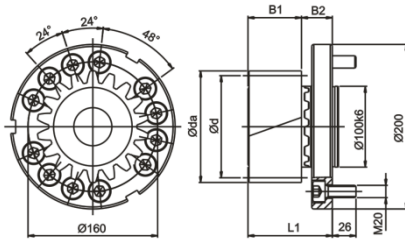

Fig. A

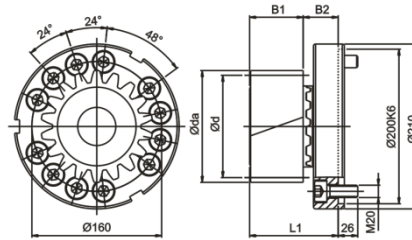

Fig. B

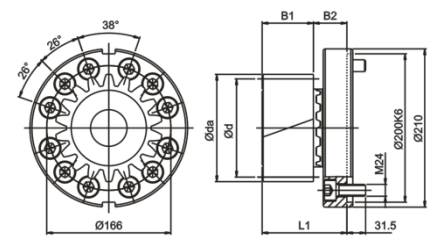
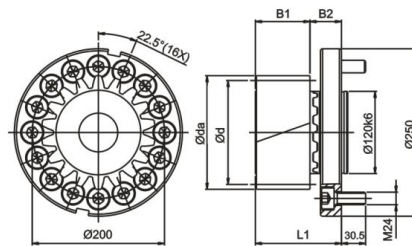

Fig. C

Mn.	z <sup>(1)</sup>	x <sup>(2)</sup>	da <sup>(3)</sup>	d <sup>(4)</sup>	dw <sup>(5)</sup>	B1	B2	L1	L <sup>(6)</sup>	Fig	Order Code	
											Set	Pinion only
6	18	0.201	129.00	114.592	117.0	61	49	110	360.000	A	A06L18A160	A06L18
										B	A06L18B160	
										C	A06L18C166	
6	19	0.404	137.80	120.958	125.8	61	49	110	380.000	A	A06L19A160	A06L19
										B	A06L19B160	
										C	A06L19C166	
8	19	0.411	183.85	161.277	167.85	81	49	130	506.667	A	A08L19A160	A08L19
										B	A08L19B160	
										C	A08L19C166	

Bolt Circle  $\varnothing 200$



Mn.	z <sup>(1)</sup>	x <sup>(2)</sup>	da <sup>(3)</sup>	d <sup>(4)</sup>	dw <sup>(5)</sup>	B1	B2	L1	L <sup>(6)</sup>	Order Code	
										Set	Pinion only
8	15	0.355	149.00	127.324	133.00	81	50	131	400.000	A08L15A200	A08L15
	19	0.411	183.85	161.277	167.85	81	50	131	506.667	A08L19A200	A08L19

(1) Number of teeth (2) Profile modification factor (3) Diameter of addendum circle (4) Pitch circle diameter  
 (5) Working pitch circle diameter (6) Pitch circle length  $L = \pi \times d$



Quality DIN 4 / Alloy Steel  
 Tooth Thickness Tolerance : e24  
 Left-Hand Helical Teeth  
 Case-Hardened and Teeth Ground

Bolt Circle Ø250

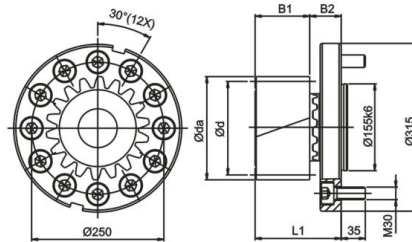

Mn.	z <sup>(1)</sup>	x <sup>(2)</sup>	da <sup>(3)</sup>	d <sup>(4)</sup>	dw <sup>(5)</sup>	B1	B2	L1	L <sup>(6)</sup>	Order Code	
										Set	Pinion only
10	14	0.523	179.0	148.545	159.0	101	62	163	466.667	A10L14A250	A10L14
	18	0.426	219.5	190.986	199.5	101	62	163	600.000	A10L18A250	A10L18

(1) Number of teeth (2) Profile modification factor (3) Diameter of addendum circle (4) Pitch circle diameter  
 (5) Working pitch circle diameter (6) Pitch circle length  $L = \pi \times d$

Pinion material carburized, surface hardness reached 60 HRc  
 Teeth surface ground to reduce noise and improve wear resistance  
 Accessories include hexagon socket head cap screws (Strength 12.9 , DIN 912)

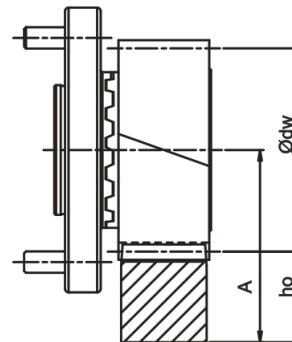
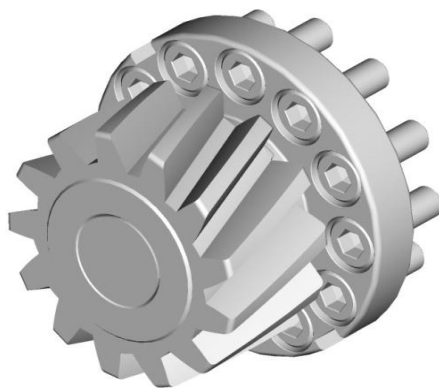

$$A = h_o + \frac{\phi dw}{2}$$

In Table 1, the maximum permissible torque of the pinion Curvic Plate and the rack is calculated on the basis of a speed of 1.5 m/s and providing good lubrication (using an automatic lubrication system or manually applied grease every day), the tooth root strength factor  $S_F \geq 1.4$ , tooth surface strength coefficient  $S_H \geq 1$ , the safety factor  $S_b \approx 1$ , and the required service life of 20,000 hours. By higher speed, the max. permissible torque reduced. The user needs to increase the safety factor for the application. Backlash changes by different center height. Please contact APEX under [WWW.APEXDYNA.COM](http://WWW.APEXDYNA.COM).

# Pinion with Helical Teeth

( Interface : Curvic Plate / EN ISO 9409-I-A )

Table I. The max. permitted torque and feed-force of pinion Curvic Plate

Pinion Rack			Quality	Q4	Q5H	Q5		Q6	Q6M	Q8H	Q8	Q9	Q10
			Material	Carbon Steel	Alloy Steel		Carbon Steel	Carbon Steel	Carbon Steel	Q&T Alloy Steel	Carbon Steel	Stainless Steel	Carbon Steel
			Heat Treatment	Induction Hardening	Case Hardening	Carburized Induction	Induction Hardening	Induction Hardening	Induction Hardening	Quenched Tempered	Normalizing	Solution	Induction Hardening
Mn	z <sup>(1)</sup>	dw <sup>(5)</sup>	Max. Torque * and Feed-Force										
2	17	37.84	F <sub>2T</sub> <sup>(8)</sup> (N)		8,870	8,870		8,870	8,870	3,326	1,940		4,158
			T <sub>2B</sub> <sup>(9)</sup> (Nm)		160	160		160	160	60	35		75
	20	44	F <sub>2T</sub> <sup>(8)</sup> (N)		9,896	9,896		8,247	8,247	2,356	1,649		4,006
			T <sub>2B</sub> <sup>(9)</sup> (Nm)		210	210		175	175	50	35		85
3	17	56.76	F <sub>2T</sub> <sup>(8)</sup> (N)		18,110	18,110		17,741	17,741	8,501	4,435		12,197
			T <sub>2B</sub> <sup>(9)</sup> (Nm)		390	390		480	480	230	120		330
	18	58	F <sub>2T</sub> <sup>(8)</sup> (N)		20,420	20,420		18,850	18,850	10,472	5,585		14,661
			T <sub>2B</sub> <sup>(9)</sup> (Nm)		585	585		540	540	300	160		420
	20	66	F <sub>2T</sub> <sup>(8)</sup> (N)		18,535	18,535		15,708	15,708	6,911	3,142		10,838
			T <sub>2B</sub> <sup>(9)</sup> (Nm)		590	590		500	500	220	100		345
4	18	81.5	F <sub>2T</sub> <sup>(8)</sup> (N)		30,761		30,761	30,761	30,761	18,719	9,948		21,206
			T <sub>2B</sub> <sup>(9)</sup> (Nm)		1,175		1,175	1,175	1,175	715	380		810
	19	83.92	F <sub>2T</sub> <sup>(8)</sup> (N)		32,247		32,247	32,119	32,119	21,950	11,905		22,818
			T <sub>2B</sub> <sup>(9)</sup> (Nm)		1,300		1,300	1,295	1,295	885	480		920
	20	86.4	F <sub>2T</sub> <sup>(8)</sup> (N)		34,283		29,452	29,452	29,452	15,669	7,893		21,324
			T <sub>2B</sub> <sup>(9)</sup> (Nm)		1,455		1,250	1,250	1,250	665	335		905
5	18	98	F <sub>2T</sub> <sup>(8)</sup> (N)	56,339	56,339		56,339	56,339	56,339		20,630		47,438
			T <sub>2B</sub> <sup>(9)</sup> (Nm)	2,690	2,690		2,690	2,690	2,690		985		2,265
	19	104.8	F <sub>2T</sub> <sup>(8)</sup> (N)	56,649	56,648		56,649	56,549	56,549		21,826		47,620
			T <sub>2B</sub> <sup>(9)</sup> (Nm)	2,855	2,855		2,855	2,850	2,850		1,100		2,400
6	18	117	F <sub>2T</sub> <sup>(8)</sup> (N)	77,580	77,580		77,580	77,580	77,580		33,947		67,544
			T <sub>2B</sub> <sup>(9)</sup> (Nm)	4,445	4,445		4,445	4,445	4,445		1,945		3,870
	19	125.8	F <sub>2T</sub> <sup>(8)</sup> (N)	73,662	73,662		73,662	73,662	73,662		35,136		63,741
			T <sub>2B</sub> <sup>(9)</sup> (Nm)	4,455	4,455		4,455	4,455	4,455		2,125		3,855
8	15	133	F <sub>2T</sub> <sup>(8)</sup> (N)	135,717	135,795		135,717	135,638	135,638		40,919		102,966
			T <sub>2B</sub> <sup>(9)</sup> (Nm)	8,640	8,645		8,640	8,635	8,635		2,605		6,555
	19	167.85	F <sub>2T</sub> <sup>(8)</sup> (N)	131,761	131,761		131,761	131,699	131,699		62,315		95,736
			T <sub>2B</sub> <sup>(9)</sup> (Nm)	10,625	10,625		10,625	10,620	10,620		5,025		7,720
10	14	159	F <sub>2T</sub> <sup>(8)</sup> (N)	189,707	189,707		189,707	189,707	189,707		62,877		153,691
			T <sub>2B</sub> <sup>(9)</sup> (Nm)	14,090	14,090		14,090	14,090	14,090		4,670		11,415
	18	199.5	F <sub>2T</sub> <sup>(8)</sup> (N)	204,308	204,308		204,308	204,256	204,256		100,636		166,766
			T <sub>2B</sub> <sup>(9)</sup> (Nm)	19,510	19,510		19,510	19,505	19,505		9,610		15,925

\* The Maximal Driving Torque is also to be understood as the Maximal Acceleration Torque T<sub>2B</sub>.

The Emergency Stop Torque T<sub>2NOT</sub> = 2 x T<sub>2B</sub>, under the condition limited 1000 times in the whole service period.

(1) Number of Teeth    (5) Working Pitch Circle Diameter (in mm)    (8) Maximum Feed-Force    (9) Maximum Driving Torque

# Pinion with Helical Teeth

( Interface : Welded Plate / EN ISO 9409-I-A )

Quality DIN 4 / Alloy Steel  
 Tooth Thickness Tolerance : e24  
 Left-Hand Helical Teeth  
 Case-Hardened and Teeth Ground

Bolt Circle Ø50

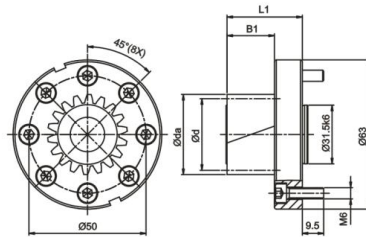

Mn.	z <sup>(1)</sup>	x <sup>(2)</sup>	da <sup>(3)</sup>	d <sup>(4)</sup>	dw <sup>(5)</sup>	BI	LI	L <sup>(6)</sup>	Order Code
2	12	0.5	31.465	25.465	27.465	26	41	80.000	B02L12A050
	16	0.0	37.953	33.953	33.953	26	41	106.667	B02L16A050

Bolt Circle Ø63

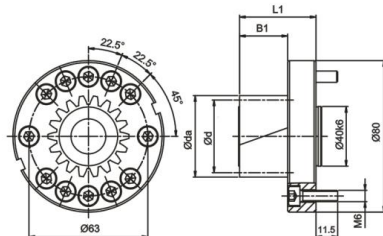

Mn.	z <sup>(1)</sup>	x <sup>(2)</sup>	da <sup>(3)</sup>	d <sup>(4)</sup>	dw <sup>(5)</sup>	BI	LI	L <sup>(6)</sup>	Order Code
2	12	0.5	31.465	25.465	27.465	26.0	41.0	80.000	B02L12A063
	17	0.0	40.075	36.075	36.075	26.0	41.0	113.333	B02L17A063
	19	0.0	44.319	40.319	40.319	26.0	41.0	126.667	B02L19A063
	23	0.0	52.808	48.808	48.808	26.0	41.0	153.334	B02L23A063
3	12	0.5	47.197	38.197	41.197	32.5	47.5	120.000	B03L12A063
	14	0.3	52.363	44.563	46.363	32.5	47.5	140.000	B03L14A063

Quality DIN 4 / Alloy Steel  
 Tooth Thickness Tolerance : e24  
 Left-Hand Helical Teeth  
 Case-Hardened and Teeth Ground

Bolt Circle Ø80

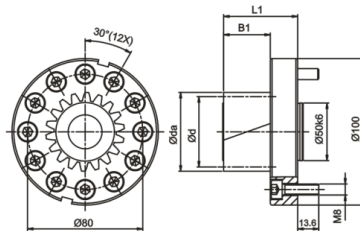

Mn.	z <sup>(1)</sup>	x <sup>(2)</sup>	da <sup>(3)</sup>	d <sup>(4)</sup>	dw <sup>(5)</sup>	BI	LI	L <sup>(6)</sup>	Order Code
2	12	0.5	31.465	25.465	27.465	26.0	46.0	80.000	B02LI2A080
	23	0.0	52.808	48.808	48.808	26.0	46.0	153.334	B02L23A080
	29	0.0	65.540	61.540	61.540	26.0	46.0	193.334	B02L29A080
3	12	0.5	47.197	38.197	41.197	32.5	52.5	120.000	B03LI2A080
	16	0.0	56.930	50.930	50.930	32.5	52.5	160.000	B03LI6A080
	17	0.0	60.113	54.113	54.113	32.5	52.5	170.000	B03LI7A080
	19	0.0	66.479	60.479	60.479	32.5	52.5	190.000	B03LI9A080
4	12	0.5	62.930	50.930	54.930	45.0	65.0	160.000	B04LI2A080

Bolt Circle Ø125

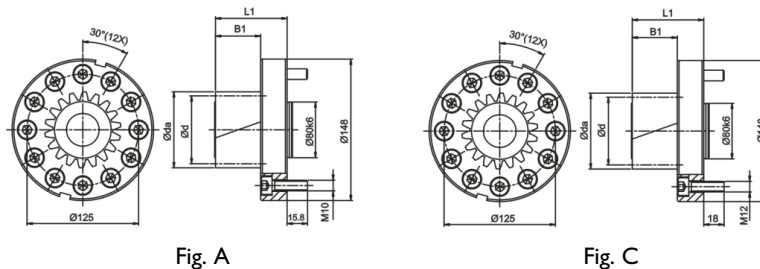

Fig. A

Fig. C

Mn.	z <sup>(1)</sup>	x <sup>(2)</sup>	da <sup>(3)</sup>	d <sup>(4)</sup>	dw <sup>(5)</sup>	BI	LI	L <sup>(6)</sup>	Fig	Order Code
3	12	0.50	47.197	38.197	41.197	32.5	57.5	120.000	A	B03LI2A125
									C	B03LI2C125
	19	0.00	66.479	60.479	60.479	32.5	57.5	190.000	A	B03LI9A125
									C	B03LI9C125
	25	0.00	85.578	79.578	79.578	32.5	57.5	250.000	A	B03L25A125
	26	0.00	88.761	82.761	82.761	32.5	57.5	260.000	A	B03L26A125
C									B03L26C125	
32	0.00	107.859	101.859	101.859	32.5	57.5	320.000	A	B03L32A125	

(1) Number of teeth (2) Profile modification factor (3) Diameter of addendum circle (4) Pitch circle diameter  
 (5) Working pitch circle diameter (6) Pitch circle length  $L = L = \pi \times d$

# Pinion with Helical Teeth

( Interface : Welded Plate / EN ISO 9409-I-A )

Quality DIN 4 / Alloy Steel

Tooth Thickness Tolerance : e24

Left-Hand Helical Teeth

Case-Hardened and Teeth Ground

Bolt Circle  $\varnothing 125$

Mn.	z <sup>(1)</sup>	x <sup>(2)</sup>	da <sup>(3)</sup>	d <sup>(4)</sup>	dw <sup>(5)</sup>	BI	LI	L <sup>(6)</sup>	Fig	Order Code
4	12	0.50	62.930	50.930	54.930	45.0	70.0	160.000	A	B04LI2A125
									C	B04LI2C125
	15	0.00	71.662	63.662	63.662	45.0	70.0	200.000	A	B04LI5A125
	16	0.00	75.906	67.906	67.906	45.0	70.0	213.334	A	B04LI6A125
	17	0.00	80.150	72.150	72.150	45.0	70.0	226.667	A	B04LI7A125
									C	B04LI7C125
	19	0.11	89.519	80.639	81.519	45.0	70.0	253.334	A	B04LI9A125
C									B04LI9C125	
20	0.00	92.883	84.883	84.883	45.0	70.0	266.667	A	B04L20A125	
								C	B04L20C125	
23	0.00	105.615	97.615	97.615	45.0	70.0	306.667	A	B04L23A125	
5	12	0.50	78.662	63.662	68.662	55	80	200.000	A	B05LI2A125
									C	B05LI2C125
	16	0.00	94.883	84.883	84.883	55	80	266.667	A	B05LI6A125
									C	B05LI6C125
	18	0.00	105.493	95.493	95.493	55	80	300.000	A	B05LI8A125
									C	B05LI8C125
6	12	0.50	94.394	76.394	82.394	65	90	240.000	A	B06LI2A125
									C	B06LI2C125
	13	0.50	100.761	82.761	88.761	65	90	260.000	A	B06LI3A125
15	0.00	107.493	95.493	95.493	65	90	300.000	A	B06LI5A125	

Bolt Circle  $\varnothing 140$  /  $\varnothing 145$

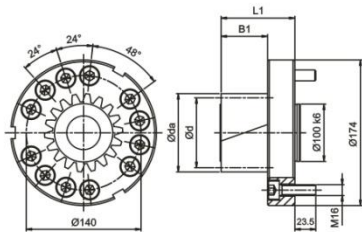

Fig. A

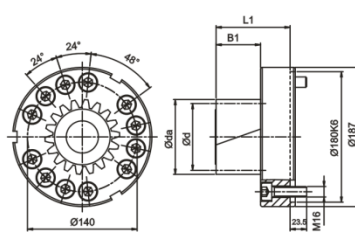

Fig. B

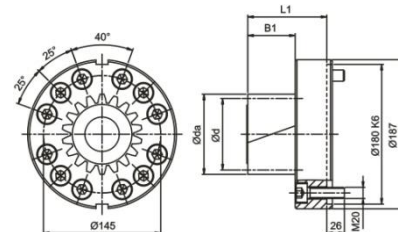

Fig. C

Mn.	z <sup>(1)</sup>	x <sup>(2)</sup>	da <sup>(3)</sup>	d <sup>(4)</sup>	dw <sup>(5)</sup>	BI	LI	L <sup>(6)</sup>	Fig	Order Code
4	12	0.50	62.930	50.930	54.930	45	79	160.000	A	B04LI2A140
									B	B04LI2B140
	19	0.11	89.519	80.639	81.519	45	79	253.334	A	B04LI9A140
									B	B04LI9B140
	20	0.00	92.883	84.883	84.883	45	79	266.667	A	B04L20A140
									B	B04L20B140
C	B04L20C145									
5	14	0.30	87.272	74.272	77.272	55	89	233.334	A	B05LI4A140
									B	B05LI4B140
	18	0.00	105.493	95.493	95.493	55	89	300.000	A	B05LI8A140
									B	B05LI8B140
	19	0.00	110.798	100.798	100.798	55	89	316.667	A	B05LI9A140
B	B05LI9B140									
6	12	0.50	94.394	76.394	82.394	65	99	240.000	A	B06LI2A140
									B	B06LI2B140
	15	0.00	107.493	95.493	95.493	65	99	300.000	A	B06LI5A140
									B	B06LI5B140
	16	0.00	113.859	101.859	101.859	65	99	320.000	A	B06LI6A140
									B	B06LI6B140

# Pinion with Helical Teeth

( Interface : Welded Plate / EN ISO 9409-I-A )

Quality DIN 4 / Alloy Steel

Tooth Thickness Tolerance : e24

Left-Hand Helical Teeth

Case-Hardened and Teeth Ground

Bolt Circle Ø160

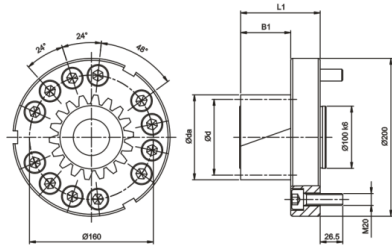

Fig. A

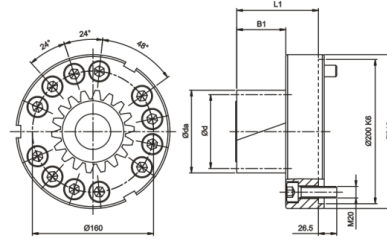

Fig. B

Mn.	z <sup>(1)</sup>	x <sup>(2)</sup>	da <sup>(3)</sup>	d <sup>(4)</sup>	dw <sup>(5)</sup>	B1	L1	L <sup>(6)</sup>	Fig	Order Code
5	12	0.5	78.662	63.662	68.662	55	100	200.000	A	B05L12A160
									B	B05L12B160
	19	0.0	110.798	100.798	100.798	55	100	316.667	A	B05L19A160
									B	B05L19B160
6	12	0.5	94.394	76.394	82.394	65	110	240.000	A	B06L12A160
									B	B06L12B160
	16	0.0	113.859	101.859	101.859	65	110	320.000	A	B06L16A160
									B	B06L16B160
8	12	0.5	125.859	101.859	109.859	85	130	320.000	A	B08L12A160
									B	B08L12B160

(1) Number of teeth (2) Profile modification factor (3) Diameter of addendum circle (4) Pitch circle diameter  
 (5) Working pitch circle diameter (6) Pitch circle length  $L = \pi \times d$

Pinion material carburized, surface hardness reached 60 HRc

Teeth surface ground to reduce noise and improve wear resistance

Accessories include hexagon socket head cap screws ( Strength 12.9 , DIN 912 )

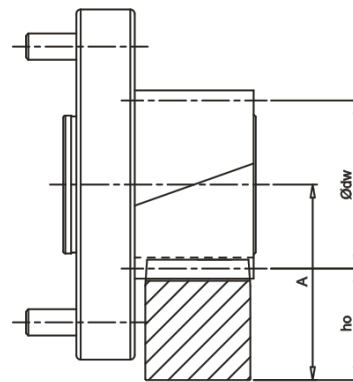

$$A = ho + \frac{\phi dw}{2}$$

In Table 2, the maximum permissible torque of the pinion Welded Plate and the rack is calculated on the basis of a speed of 1.5 m/s and providing good lubrication (using an automatic lubrication system or manually applied grease every day), the tooth root strength factor  $S_F \geq 1.4$ , tooth surface strength coefficient  $S_H \geq 1$ , the safety factor  $S_B \cong 1$ , and the required service life of 20,000 hours. By higher speed, the max. permissible torque reduced. The user needs to increase the safety factor for the application.

Backlash changes by different center height. Please contact APEX under [WWW.APEXDYNA.COM](http://WWW.APEXDYNA.COM).

Note : The strength of screws is limits the max. transmission torque. Please refer to the table below for Pinion Welded Plate.

PCD of Flange	Bolt / Screw Size	Max. Torque (Nm)
Ø50	M6	175
Ø63	M6	335
Ø80	M8	810
Ø125	M10	2,055
	M12	3,060
Ø140	M16	6,620
Ø145	M20	10,885
Ø160	M20	12,000

Table 2. The max. permitted torque and feed-force of pinion Welded Plate

Pinion \ Rack			Quality	Q4	Q5H	Q5		Q6	Q6M	Q8H	Q8	Q9	Q10	
			Material	Carbon Steel	Alloy Steel		Carbon Steel	Carbon Steel	Carbon Steel	Carbon Steel	Q&T Alloy Steel	Carbon Steel	Stainless Steel	Carbon Steel
			Heat Treatment	Induction Hardening	Case Hardening	Carburized Induction	Induction Hardening	Induction Hardening	Induction Hardening	Induction Hardening	Quenched Tempered	Normalizing	Solution	Induction Hardening
Mn	z <sup>(1)</sup>	dw <sup>(5)</sup>	Max. Torque * and Feed-Force											
2	12	27.465	F <sub>2T</sub> <sup>(8)</sup> (N)		6,676	6,676		6,283	6,283	1,571	1,178	-	2,356	
			T <sub>2B</sub> <sup>(9)</sup> (Nm)		85	85		80	80	20	15	-	30	
	16	33.953	F <sub>2T</sub> <sup>(8)</sup> (N)		10,603	10,603		9,425	9,425	3,240	1,767	-	5,596	
			T <sub>2B</sub> <sup>(9)</sup> (Nm)		180	180		160	160	55	30	-	95	
	17	36.075	F <sub>2T</sub> <sup>(8)</sup> (N)		10,811	10,811		9,425	9,425	3,881	1,663	-	5,544	
			T <sub>2B</sub> <sup>(9)</sup> (Nm)		195	195		170	170	70	30	-	100	
	19	40.319	F <sub>2T</sub> <sup>(8)</sup> (N)		11,161	11,161		9,673	9,673	4,960	2,480	-	5,704	
			T <sub>2B</sub> <sup>(9)</sup> (Nm)		225	225		195	195	100	50	-	115	
	23	48.808	F <sub>2T</sub> <sup>(8)</sup> (N)		10,654	10,654		8,810	8,810	3,893	2,049	-	4,507	
			T <sub>2B</sub> <sup>(9)</sup> (Nm)		260	260		215	215	95	50	-	110	
	29	61.54	F <sub>2T</sub> <sup>(8)</sup> (N)		10,725	10,725		8,937	8,937	6,012	2,925	-	4,225	
			T <sub>2B</sub> <sup>(9)</sup> (Nm)		330	330		275	275	185	90	-	130	
3	12	41.197	F <sub>2T</sub> <sup>(8)</sup> (N)		12,828	12,828		12,566	12,566	3,927	2,356	-	6,807	
			T <sub>2B</sub> <sup>(9)</sup> (Nm)		245	245		240	240	75	45	-	130	
	14	46.363	F <sub>2T</sub> <sup>(8)</sup> (N)		16,605	16,605		16,157	16,157	6,059	2,917	-	10,771	
			T <sub>2B</sub> <sup>(9)</sup> (Nm)		370	370		360	360	135	65	-	240	
	16	50.93	F <sub>2T</sub> <sup>(8)</sup> (N)		19,439	19,439		18,850	18,850	8,836	4,516	-	13,941	
			T <sub>2B</sub> <sup>(9)</sup> (Nm)		495	495		480	480	225	115	-	355	
	17	54.113	F <sub>2T</sub> <sup>(8)</sup> (N)		19,774	19,774		19,034	19,034	9,794	5,174	-	14,045	
			T <sub>2B</sub> <sup>(9)</sup> (Nm)		535	535		545	545	265	140	-	380	
	19	60.479	F <sub>2T</sub> <sup>(8)</sup> (N)		20,338	20,338		19,346	19,346	11,905	6,449	-	14,551	
			T <sub>2B</sub> <sup>(9)</sup> (Nm)		615	615		585	585	360	195	-	440	
	25	79.578	F <sub>2T</sub> <sup>(8)</sup> (N)		19,729	19,729		16,713	16,713	11,687	6,283	-	11,561	
			T <sub>2B</sub> <sup>(9)</sup> (Nm)		785	785		665	665	465	250	-	460	
	26	82.761	F <sub>2T</sub> <sup>(8)</sup> (N)		19,695	19,695		16,675	16,675	12,445	6,766	-	11,600	
			T <sub>2B</sub> <sup>(9)</sup> (Nm)		815	815		690	690	515	280	-	480	
	32	101.859	F <sub>2T</sub> <sup>(8)</sup> (N)		19,831	19,831		16,788	16,788	12,468	9,327	-	11,290	
			T <sub>2B</sub> <sup>(9)</sup> (Nm)		1,010	1,010		855	855	635	475	-	575	

\* The Maximal Driving Torque is also to be understood as the Maximal Acceleration Torque T<sub>2B</sub>.

The Emergency Stop Torque T<sub>2NOT</sub> = 2 x T<sub>2B</sub>, under the condition limited 1000 times in the whole service period.

(1) Number of Teeth (5) Working Pitch Circle Diameter (in mm) (8) Maximum Feed-Force (9) Maximum Driving Torque

# Pinion with Helical Teeth

( Interface : Welded Plate / EN ISO 9409-I-A )

Table 2. The max. permitted torque and feed-force of pinion Welded Plate

Pinion Rack			Quality	Q4	Q5H	Q5		Q6	Q6M	Q8H	Q8	Q9	Q10	
			Material	Carbon Steel	Alloy Steel		Carbon Steel	Carbon Steel	Carbon Steel	Carbon Steel	Q&T Alloy Steel	Carbon Steel	Stainless Steel	Carbon Steel
			Heat Treatment	Induction Hardening	Case Hardening	Carburized Induction	Induction Hardening	Induction Hardening	Induction Hardening	Induction Hardening	Quenched Tempered	Normalizing	Solution	Induction Hardening
Mn	z <sup>(1)</sup>	dw <sup>(5)</sup>	Max. Torque * and Feed-Force											
4	12	54.93	F <sub>2T</sub> <sup>(8)</sup> (N)		22,187		22,187	21,991	21,991	9,032	3,927		12,174	
			T <sub>2B</sub> <sup>(9)</sup> (Nm)		565		565	560	560	230	100		310	
	15	63.662	F <sub>2T</sub> <sup>(8)</sup> (N)		31,102		31,102	31,102	31,102	16,336	8,482		21,991	
			T <sub>2B</sub> <sup>(9)</sup> (Nm)		990		990	990	990	520	270		700	
	16	67.906	F <sub>2T</sub> <sup>(8)</sup> (N)		33,870		33,870	33,870	33,870	18,260	9,719		25,182	
			T <sub>2B</sub> <sup>(9)</sup> (Nm)		1,150		1,150	1,150	1,150	620	330		855	
	17	72.15	F <sub>2T</sub> <sup>(8)</sup> (N)		36,729		35,897	35,897	35,897	20,236	10,949		28,551	
			T <sub>2B</sub> <sup>(9)</sup> (Nm)		1,325		1,295	1,295	1,295	730	395		1,030	
	19	81.519	F <sub>2T</sub> <sup>(8)</sup> (N)		36,707		36,211	36,211	36,211	23,686	13,145		27,778	
			T <sub>2B</sub> <sup>(9)</sup> (Nm)		1,480		1,460	1,460	1,460	955	530		1,120	
	20	84.883	F <sub>2T</sub> <sup>(8)</sup> (N)		35,107		30,159	30,159	30,159	16,493	8,364		22,148	
			T <sub>2B</sub> <sup>(9)</sup> (Nm)		1,490		1,280	1,280	1,280	700	355		940	
	23	97.615	F <sub>2T</sub> <sup>(8)</sup> (N)		35,240		30,323	30,323	30,323	21,001	11,269		22,025	
			T <sub>2B</sub> <sup>(9)</sup> (Nm)		1,720		1,480	1,480	1,480	1,025	550		1,075	
5	12	68.662	F <sub>2T</sub> <sup>(8)</sup> (N)	31,259	31,259		31,259	30,945	30,945		8,482		19,007	
			T <sub>2B</sub> <sup>(9)</sup> (Nm)	995	995		995	985	985		270		605	
	14	77.272	F <sub>2T</sub> <sup>(8)</sup> (N)	42,142	42,142		42,142	42,142	42,142		12,656		30,967	
			T <sub>2B</sub> <sup>(9)</sup> (Nm)	1,565	1,565		1,565	1,565	1,565		470		1,150	
	16	84.883	F <sub>2T</sub> <sup>(8)</sup> (N)	47,713	47,713		47,713	47,595	47,595		18,025		36,992	
			T <sub>2B</sub> <sup>(9)</sup> (Nm)	2,025	2,025		2,025	2,020	2,020		765		1,570	
	18	95.493	F <sub>2T</sub> <sup>(8)</sup> (N)	55,187	55,187		55,187	55,083	55,083		22,096		46,181	
			T <sub>2B</sub> <sup>(9)</sup> (Nm)	2,635	2,635		2,635	2,630	2,630		1,055		2,205	
	19	100.798	F <sub>2T</sub> <sup>(8)</sup> (N)	55,854	55,854		55,854	55,755	55,755		24,207		46,727	
			T <sub>2B</sub> <sup>(9)</sup> (Nm)	2,815	2,815		2,815	2,810	2,810		1,220		2,355	
6	12	82.394	F <sub>2T</sub> <sup>(8)</sup> (N)	41,233	41,233		41,233	41,102	41,102		14,792		26,965	
			T <sub>2B</sub> <sup>(9)</sup> (Nm)	1,575	1,575		1,575	1,570	1,570		565		1,030	
	13	88.761	F <sub>2T</sub> <sup>(8)</sup> (N)	45,311	45,311		45,311	45,191	45,191		17,400		31,295	
			T <sub>2B</sub> <sup>(9)</sup> (Nm)	1,875	1,875		1,875	1,870	1,870		720		1,295	
	15	95.493	F <sub>2T</sub> <sup>(8)</sup> (N)	57,701	57,701		57,701	57,596	57,596		26,285		44,611	
			T <sub>2B</sub> <sup>(9)</sup> (Nm)	2,755	2,755		2,755	2,750	2,750		1,255		2,130	
	16	101.859	F <sub>2T</sub> <sup>(8)</sup> (N)	62,832	62,832		62,832	62,832	62,832		29,452		50,854	
			T <sub>2B</sub> <sup>(9)</sup> (Nm)	3,200	3,200		3,200	3,200	3,200		1,500		2,590	
8	12	109.859	F <sub>2T</sub> <sup>(8)</sup> (N)	63,814	63,814		63,814	63,715	63,715		31,710		41,921	
			T <sub>2B</sub> <sup>(9)</sup> (Nm)	3,250	3,250		3,250	3,245	3,245		1,615		2,135	

\* The Maximal Driving Torque is also to be understood as the Maximal Acceleration Torque T<sub>2B</sub>.

The Emergency Stop Torque T<sub>2NOT</sub> = 2 x T<sub>2B</sub>, under the condition limited 1000 times in the whole service period.

(1) Number of Teeth (5) Working Pitch Circle Diameter (in mm) (8) Maximum Feed-Force (9) Maximum Driving Torque



# Pinion with Helical Teeth

( Interface : Teeth Plate / EN ISO 9409-1-A )

Quality DIN 4 / Alloy Steel  
Tooth Thickness Tolerance : e24  
Left-Hand Helical Teeth  
Case-Hardened and Teeth Ground

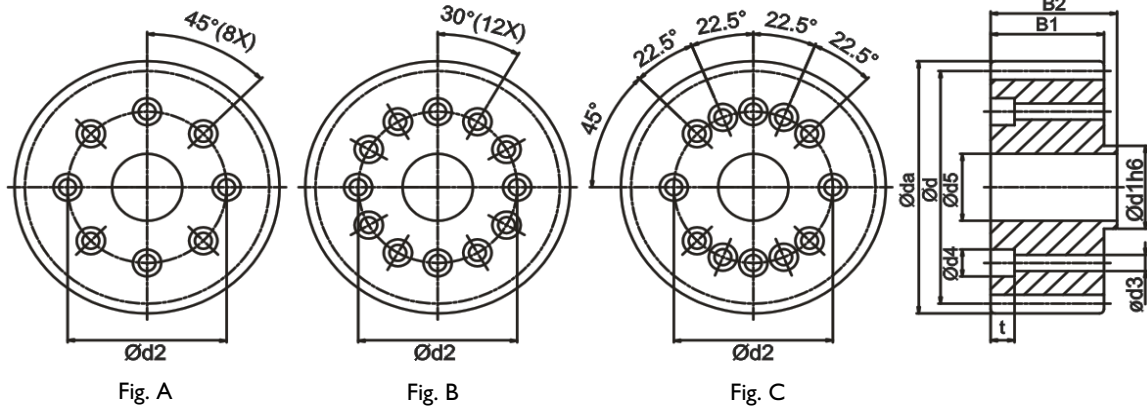

Mn	z <sup>(1)</sup>	x <sup>(2)</sup>	da <sup>(3)</sup>	d <sup>(4)</sup>	dw <sup>(5)</sup>	d1	d2	B1	B2	d3	d4	t	d5	L <sup>(6)</sup>	Fig	Order Code
2	26	0.407	60.800	55.174	56.800	20.0	31.5	26	29	5.5	9.5	12.0	16.2	173.334	A	C02L26A031
	27	0.000	61.296	57.296	57.296	20.0	31.5	30	33	5.5	9.5	11.0	16.2	180.000	A	C02L27A031
	29	0.415	67.200	61.540	63.200	20.0	31.5	26	29	5.5	9.5	12.0	16.2	193.334	A	C02L29A031
	35	0.382	79.800	74.272	75.800	20.0	31.5	26	29	5.5	9.5	12.0	16.2	233.334	A	C02L35A031
	29	0.415	67.200	61.540	63.200	25.0	40.0	26	29	6.6	11.0	10.5	20.3	193.334	A	C02L29A040
	33	0.393	75.599	70.028	71.599	31.5	50.0	26	29	6.6	11.0	14.0	23.7	220.000	A	C02L33A050
	36	0.000	80.394	76.394	76.394	31.5	50.0	30	33	6.6	11.0	8.0	23.7	240.000	A	C02L36A050
	37	0.421	84.200	78.517	80.200	31.5	50.0	26	29	6.6	11.0	14.0	23.7	246.667	A	C02L37A050
	37	0.421	84.200	78.517	80.200	31.5	50.0	26	29	6.6	11.0	14.0	23.7	246.667	B	C02L37B050
	40	0.379	90.400	84.883	86.400	40.0	63.0	26	29	6.6	11.0	11.5	32.2	266.667	C	C02L40C063
	45	0.327	100.800	95.493	96.800	40.0	63.0	26	29	6.6	11.0	11.5	32.2	300.000	C	C02L45C063
3	30	0.000	101.493	95.493	95.493	40.0	63.0	35	39	6.6	11.0	9.5	32.2	300.000	C	C03L30C063
	31	0.354	106.800	98.676	100.800	31.5	50.0	31	35	6.6	11.0	9.0	23.7	310.000	A	C03L31A050
	35	0.365	119.600	111.409	113.600	50.0	80.0	31	35	9.0	14.0	10.5	32.2	350.000	B	C03L35B080
	40	0.379	135.599	127.324	129.599	50.0	80.0	31	35	9.0	14.0	10.5	32.2	400.000	B	C03L40B080
4	30	0.000	135.324	127.324	127.324	50.0	80.0	45	49	9.0	14.0	9.5	32.2	400.000	B	C04L30B080
	38	0.240	171.200	161.277	163.200	80.0	125.0	41	45	11.0	17.5	10.5	56.1	506.667	B	C04L38B125
5	21	0.000	121.409	111.409	111.409	50.0	80.0	59	64	9.0	14.0	11.5	32.2	350.000	B	C05L21B080
	36	0.000	200.986	190.986	190.986	80.0	125.0	55	60	11.0	17.5	12.5	56.1	600.000	B	C05L36B125

(1) Number of teeth (2) Profile modification factor (3) Diameter of addendum circle (4) Pitch circle diameter  
(5) Working pitch circle diameter (6) Pitch circle length  $L = \pi \times d$

The surface hardness reaches to 60 HRC after case hardening  
Teeth surface ground in order to reduce noise and improve wear resistance  
Accessories include hexagon socket head cap screws (Strength 12.9 · DIN 912)

Note : The strength of screws is limits the max. transmission torque. Please refer to the table below for Pinion Teeth Plate.

d1 <sub>h6</sub>	d2	Bolt / Screw Size	Max. Torque (Nm)
20	31.5	M5	75
25	40	M6	140
31.5	50	M6	175
40	63	M6	335
50	80	M8	810
80	125	M10	2,055

# Pinion with Helical Teeth

( Interface : Teeth Plate / EN ISO 9409-1-A )

Quality DIN 4 / Alloy Steel  
 Tooth Thickness Tolerance : e24  
 Left-Hand Helical Teeth  
 Case-Hardened and Teeth Ground

## Bolt Circle Ø50

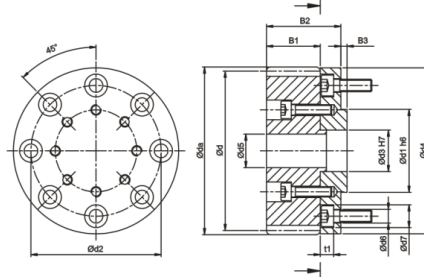

Mn.	z <sup>(1)</sup>	x <sup>(2)</sup>	da <sup>(3)</sup>	d <sup>(4)</sup>	dw <sup>(5)</sup>	d1 h <sub>6</sub>	d2	d3 H <sub>7</sub>	d4	d5	B1	B2	B3	d6	d7	t1	L <sup>(6)</sup>	Order Code	
																		Pinion	Flange
2	26	0.407	60.800	55.174	56.800	31.5	50	20	63	16.2	26	36	3	6.6	11	6.5	173.334	C02L26A031	FA050
	27	0.000	61.296	57.296	57.296	31.5	50	20	63	16.2	30	40	3	6.6	11	6.5	180.000	C02L27A031	FA050
	29	0.415	67.200	61.540	63.200	31.5	50	20	63	16.2	26	36	3	6.6	11	6.5	193.334	C02L29A031	FA050
	29	0.415	67.200	61.540	63.200	31.5	50	25	63	16.2	26	36	3	6.6	11	6.5	193.334	C02L29A040	FB050
	35	0.382	79.800	74.272	75.800	31.5	50	20	63	16.2	26	36	3	6.6	11	6.5	233.334	C02L35A031	FA050

## Bolt Circle Ø63

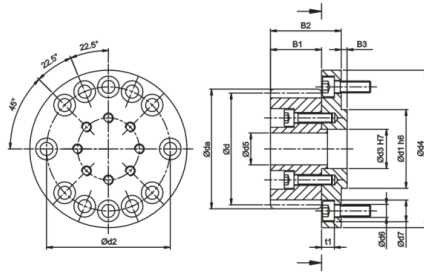

Mn.	z <sup>(1)</sup>	x <sup>(2)</sup>	da <sup>(3)</sup>	d <sup>(4)</sup>	dw <sup>(5)</sup>	d1 h <sub>6</sub>	d2	d3 H <sub>7</sub>	d4	d5	B1	B2	B3	d6	d7	t1	L <sup>(6)</sup>	Order Code	
																		Pinion	Flange
2	26	0.407	60.800	55.174	56.800	40	63	20	80	16.2	26	36	3	6.6	11	6.5	173.334	C02L26A031	FA063
	27	0.000	61.296	57.296	57.296	40	63	20	80	16.2	30	40	3	6.6	11	6.5	180.000	C02L27A031	FA063
	29	0.415	67.200	61.540	63.200	40	63	20	80	16.2	26	36	3	6.6	11	6.5	193.334	C02L29A031	FA063
	35	0.382	79.800	74.272	75.800	40	63	20	80	16.2	26	36	3	6.6	11	6.5	233.334	C02L35A031	FA063

## Bolt Circle Ø80

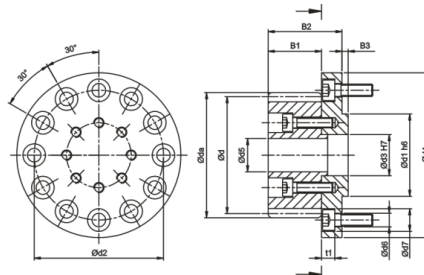

Mn.	z <sup>(1)</sup>	x <sup>(2)</sup>	da <sup>(3)</sup>	d <sup>(4)</sup>	dw <sup>(5)</sup>	d1 h <sub>6</sub>	d2	d3 H <sub>7</sub>	d4	d5	B1	B2	B3	d6	d7	t1	L <sup>(6)</sup>	Order Code	
																		Pinion	Flange
2	33	0.393	75.599	70.028	71.599	50	80	31.5	100	23.7	26	39	4	9	14	8.6	220.000	C02L33A050	FA080
	36	0.000	80.394	76.394	76.394	50	80	31.5	100	23.7	30	43	4	9	14	8.6	240.000	C02L36A050	FA080
	37	0.421	84.200	78.517	80.200	50	80	31.5	100	23.7	26	39	4	9	14	8.6	246.667	C02L37A050	FA080
3	31	0.354	106.800	98.676	100.800	50	80	31.5	100	23.7	31	44	4	9	14	8.6	310.000	C03L31A050	FA080

Quality DIN 4 / Alloy Steel  
 Tooth Thickness Tolerance : e24  
 Left-Hand Helical Teeth  
 Case-Hardened and Teeth Ground

Bolt Circle Ø125

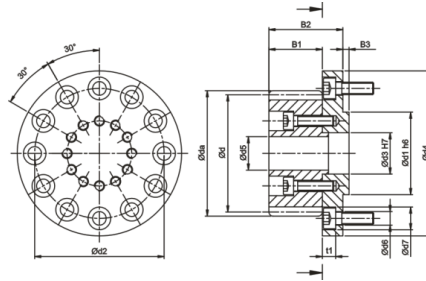

Mn.	z <sup>(1)</sup>	x <sup>(2)</sup>	da <sup>(3)</sup>	d <sup>(4)</sup>	dw <sup>(5)</sup>	d1 <sub>h6</sub>	d2	d3 <sub>H7</sub>	d4	d5	B1	B2	B3	d6	d7	t1	L <sup>(6)</sup>	Order Code	
																		Pinion	Flange
3	35	0.365	119.600	111.409	113.600	80	125	50	148	32.2	31	50	6	11	17.5	14	350	C03L35B080	FA125
	40	0.379	135.599	127.324	125.999	80	125	50	148	32.2	31	50	6	11	17.5	14	400	C03L40B080	FA125
4	30	0.000	135.324	127.324	127.324	80	125	50	148	32.2	45	64	6	11	17.5	14	400	C04L30B080	FA125
5	21	0.000	121.409	111.409	111.409	80	125	50	148	32.2	59	78	6	11	17.5	14	350	C05L21B080	FA125

(1) Number of teeth (2) Profile modification factor (3) Diameter of addendum circle (4) Pitch circle diameter  
 (5) Working pitch circle diameter (6) Pitch circle length  $L = \pi \times d$

The surface hardness reaches to 60 HRC after case hardening

Teeth surface ground in order to reduce noise and improve wear resistance

Accessories include hexagon socket head cap screws (Strength 12.9 , DIN 912)

Flange material is generally carbon steel, no heat treatment

When pinion combined with flange, the maximum allowable feed force should be checked according to bolt strength

Note : The strength of screws is limits the max. transmission torque. Please refer to the table  
 blow for Pinion Teeth Plate with Flange.

d1 <sub>h6</sub>	d2	Bolt / Screw Size	Max. Torque (Nm)
31.5	50	M6	175
40	63	M6	335
50	80	M8	810
80	125	M10	2,055

# Pinion with Helical Teeth

( Interface : Teeth Plate / EN ISO 9409-1-A )

## Friction Shim

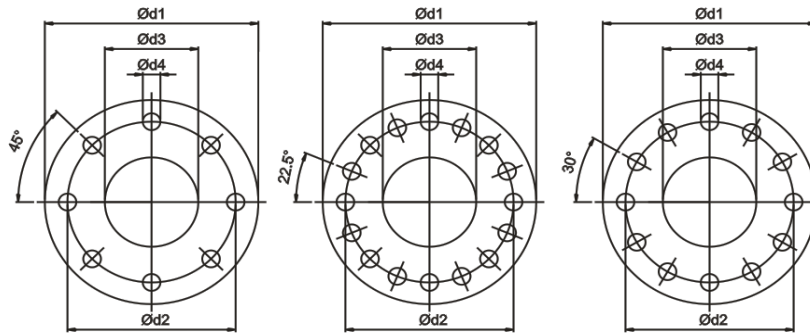

Fig. A

Fig. B

Fig. C

ISO interface	d1	d2	d3	d4	Fig	Max. Torque (Nm)	Order code
A-31.5	39	31.5	20	5.5	A	98	FR031
A-50	62	50	31.5	6.6	A	228	FR050
A-63	80	63	40	6.6	B	435	FR063
A-80	100	80	50	9	C	1050	FR080
A-125	148	125	80	11	C	2670	FR125

To apply the diamond-coated friction shim between the teeth plate and the extending flange, the static friction coefficient is increased. Hence the effective transmission torque can be enhanced at about 30%. Please also refer to the torque limitation due to screws, Page.42.



In Table 3, the maximum permissible torque of pinion Teeth Plate, and the rack is calculated on the basis of a speed of 1.5 m/s and providing good lubrication (using an automatic lubrication system or manually applied grease every day), the tooth root strength factor  $S_F \geq 1.4$ , tooth surface strength coefficient  $S_H \geq 1$ , the safety factor  $S_B \cong 1$ , and the required service life of 20,000 hours. By higher speed, the max. permissible torque reduced. The user needs to increase the safety factor for the application. Backlash changes by different center height. Please contact APEX under WWW.APEXDYNA.COM.

Table 3. The max. permitted torque and feed-force of pinion Teeth Plate

Pinion \ Rack			Quality	Q4	Q5H	Q5		Q6	Q6M	Q8H	Q8	Q9	Q10
			Material	Carbon Steel	Alloy Steel		Carbon Steel	Carbon Steel	Carbon Steel	Q&T Alloy Steel	Carbon Steel	Stainless Steel	Carbon Steel
			Heat Treatment	Induction Hardening	Case Hardening	Carburized Induction	Induction Hardening	Induction Hardening	Induction Hardening	Quenched Tempered	Normalizing	Solution	Induction Hardening
Mn	z <sup>(1)</sup>	dw <sup>(5)</sup>	Max. Torque * and Feed-Force										
2	26	56.8	F <sub>2T</sub> <sup>(8)</sup> (N)		10,150	10,150		8,519	8,519	4,350	2,175		3,806
			T <sub>2B</sub> <sup>(9)</sup> (Nm)		280	280		235	235	120	60		105
	27	57.296	F <sub>2T</sub> <sup>(8)</sup> (N)		10,646	10,646		8,901	8,901	5,411	2,443		4,014
			T <sub>2B</sub> <sup>(9)</sup> (Nm)		305	305		255	255	155	70		115
	29	63.2	F <sub>2T</sub> <sup>(8)</sup> (N)		10,075	10,075		8,450	8,450	5,525	2,600		3,737
			T <sub>2B</sub> <sup>(9)</sup> (Nm)		310	310		260	260	170	80		115
	33	70.028	F <sub>2T</sub> <sup>(8)</sup> (N)		10,424	10,424		8,568	8,568	5,712	3,713		3,713
			T <sub>2B</sub> <sup>(9)</sup> (Nm)		365	365		300	300	200	130		130
	35	75.8	F <sub>2T</sub> <sup>(8)</sup> (N)		10,367	10,367		8,617	8,617	5,655	4,174		3,635
			T <sub>2B</sub> <sup>(9)</sup> (Nm)		385	385		320	320	210	155		135
	36	76.394	F <sub>2T</sub> <sup>(8)</sup> (N)		10,734	10,734		8,901	8,901	6,021	4,320		3,927
			T <sub>2B</sub> <sup>(9)</sup> (Nm)		410	410		340	340	230	165		150
37	80.2	F <sub>2T</sub> <sup>(8)</sup> (N)		10,444	10,444		8,661	8,661	5,731	4,076		3,566	
		T <sub>2B</sub> <sup>(9)</sup> (Nm)		410	410		340	340	225	160		140	
40	86.4	F <sub>2T</sub> <sup>(8)</sup> (N)		10,485	10,485		8,718	8,718	5,655	4,123		3,652	
		T <sub>2B</sub> <sup>(9)</sup> (Nm)		445	445		370	370	240	175		155	
45	96.8	F <sub>2T</sub> <sup>(8)</sup> (N)		10,577	10,577		8,796	8,796	5,760	4,189		3,560	
		T <sub>2B</sub> <sup>(9)</sup> (Nm)		505	505		420	420	275	200		170	
3	30	95.493	F <sub>2T</sub> <sup>(8)</sup> (N)		19,792	19,792		16,755	16,755	12,462	9,006		11,310
			T <sub>2B</sub> <sup>(9)</sup> (Nm)		945	945		800	800	595	430		540
	31	100.8	F <sub>2T</sub> <sup>(8)</sup> (N)		19,153	19,153		16,215	16,215	11,958	8,817		10,742
			T <sub>2B</sub> <sup>(9)</sup> (Nm)		945	945		800	800	590	435		530
	35	113.6	F <sub>2T</sub> <sup>(8)</sup> (N)		19,298	19,298		16,247	16,247	11,938	8,976		10,592
			T <sub>2B</sub> <sup>(9)</sup> (Nm)		1,075	1,075		905	905	665	500		590
	40	129.599	F <sub>2T</sub> <sup>(8)</sup> (N)		15,708	15,708		13,273	13,273	9,817	7,383		8,718
			T <sub>2B</sub> <sup>(9)</sup> (Nm)		1,000	1,000		845	845	625	470		555
4	30	127.324	F <sub>2T</sub> <sup>(8)</sup> (N)		36,128		31,102	31,023	31,023	23,562	17,514		22,070
			T <sub>2B</sub> <sup>(9)</sup> (Nm)		2,300		1,980	1,975	1,975	1,500	1,115		1,405
	38	163.2	F <sub>2T</sub> <sup>(8)</sup> (N)		37,079		31,871	31,809	31,809	24,492	18,229		22,508
			T <sub>2B</sub> <sup>(9)</sup> (Nm)		2,890		2,570	2,565	2,565	1,975	1,470		1,815
5	21	111.409	F <sub>2T</sub> <sup>(8)</sup> (N)	47,483	55,112		47,483	47,393	47,393		17,683		37,609
			T <sub>2B</sub> <sup>(9)</sup> (Nm)	2,645	3,070		2,645	2,640	2,640		985		2,095
	36	190.986	F <sub>2T</sub> <sup>(8)</sup> (N)	52,360	60,894		52,360	52,360	52,360		31,782		42,045
			T <sub>2B</sub> <sup>(9)</sup> (Nm)	5,000	5,815		5,000	5,000	5,000		3,035		4,015

\* The Maximal Driving Torque is also to be understood as the Maximal Acceleration Torque T<sub>2B</sub>.

The Emergency Stop Torque T<sub>2NOT</sub> = 2 × T<sub>2B</sub>, under the condition limited 1000 times in the whole service period.

(1) Number of Teeth (5) Working Pitch Circle Diameter (in mm) (8) Maximum Feed-Force (9) Maximum Driving Torque

# Pinion with Helical Teeth

( Interface : DIN 5480 / Spline )

Quality DIN 5 / Alloy Steel  
 Tooth Thickness Tolerance : e24  
 Left-Hand Helical Teeth  
 Case-Hardened and Teeth Ground

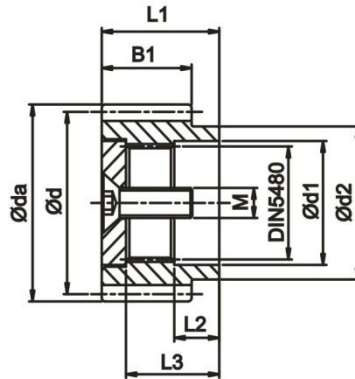

DIN 5480	Mn	z <sup>(1)</sup>	x <sup>(2)</sup>	da <sup>(3)</sup>	d <sup>(4)</sup>	dw <sup>(5)</sup>	B1	L1	d1	d2	L2	L3	L <sup>(6)</sup>	M	Order code
N16x0.8x30x18x7H	2	15	0.592	38.20	31.831	34.200	26	32	16	26	11	26.5	100.000	M5x15	D02L15N16
		16	0.612	40.40	33.953	36.400	26	32	16	28	11	26.5	106.667	M5x15	D02L16N16
		18	0.500	44.20	38.197	40.200	26	32	16	32	11	26.5	120.000	M5x15	D02L18N16
N22x1.25x30x16x7H	1.5	38	0.000	63.48	60.479	60.480	20	33	22	32	12	27.5	190.000	M8x25	D1JL38N22
		18	0.500	44.20	38.197	40.200	26	33	22	32	12	27.5	120.000	M8x25	D02L18N22
	2	20	0.490	48.40	42.441	44.400	26	33	22	34	12	27.5	133.334	M8x25	D02L20N22
		22	0.479	52.60	46.686	48.600	26	33	22	36	12	27.5	146.667	M8x25	D02L22N22
N32x1.25x30x24x7H	2	25	0.000	57.52	53.052	53.052	26	33	22	36	12	27.5	166.667	M8x25	D02L25N22
		23	0.498	54.80	48.808	50.800	26	34	32	42	13	27.0	153.334	M12x35	D02L23N32
		25	0.487	59.00	53.052	55.000	26	34	32	45	13	27.0	166.667	M12x35	D02L25N32
N40x2x30x18x7H	3	27	0.376	62.80	57.296	58.800	26	34	32	48	13	27.0	180.000	M12x35	D02L27N32
		20	0.456	72.40	63.662	66.400	31	51	40	55	20	41.0	200.000	M16x45	D03L20N40
		22	0.462	78.80	70.028	72.800	31	51	40	58	20	41.0	220.000	M16x45	D03L22N40
N55x2x30x26x7H	4	24	0.468	85.20	76.394	79.200	31	51	40	62	20	41.0	240.000	M16x45	D03L24N40
		20	0.400	96.08	84.883	88.080	41	54	55	75	20	44.0	266.667	M20x50	D04L20N55
N70x2x30x34x7H	4	25	0.340	116.82	106.103	108.820	41	65	75	94	24	55.0	333.334	M20x50	D04L25N70
N80x2x30x38x7H	5	24	0.348	104.80	127.324	130.800	51	73	85	110	24	62.5	400.000	M20x50	D05L24N80

(1) Number of teeth (2) Profile modification factor (3) Diameter of addendum circle (4) Pitch circle diameter  
 (5) Working pitch circle diameter (6) Pitch circle length  $L = \pi \times d$

Pinion material carburized, the surface hardness reaches to 60 HRc after case hardening  
 Teeth surface ground in order to reduce noise and improve wear resistance  
 Accessories include washers and hex head socket head cap screws ( Strength 8.8 · ISO 10642 / DIN 7991 )

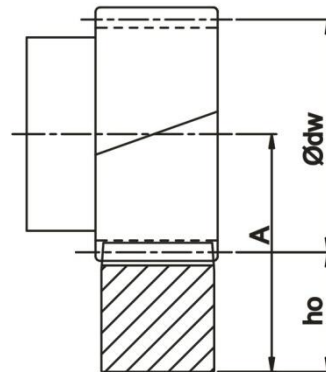
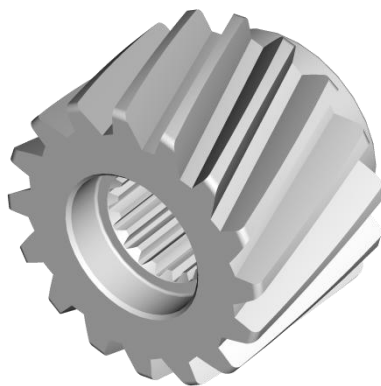

$$A = h_o + \frac{\phi dw}{2}$$

In Table 4, the maximum permissible torque of pinion with DIN 5480, and the rack is calculated on the basis of a speed of 1.5 m/s and providing good lubrication (using an automatic lubrication system or manually applied grease every day), the tooth root strength factor  $S_F \geq 1.4$ , tooth surface strength coefficient  $S_H \geq 1$ , the safety factor  $S_B \approx 1$ , and the required service life of 20,000 hours. By higher speed, the max. permissible torque reduced. The user needs to increase the safety factor for the application. Backlash changes by different center height. Please contact APEX under WWW.APEXDYNA.COM.

Table 4. The max. permitted torque and feed-force of pinion with DIN 5480

Pinion \ Rack			Quality	Q4	Q5H	Q5		Q6	Q6M	Q8H	Q8	Q9	Q10
			Material	Carbon Steel	Alloy Steel		Carbon Steel	Carbon Steel	Carbon Steel	Q&T Alloy Steel	Carbon Steel	Stainless Steel	Carbon Steel
			Heat Treatment	Induction Hardening	Case Hardening	Carburized Induction	Induction Hardening	Induction Hardening	Induction Hardening	Quenched Tempered	Normalizing	Solution	Induction Hardening
Mn	z <sup>(1)</sup>	dw <sup>(5)</sup>	Max. Torque* and Feed-Force										
1.5	38	60.48	F <sub>2T</sub> <sup>(8)</sup> (N)					5,622			1,984		1,653
			T <sub>2B</sub> <sup>(9)</sup> (Nm)					170			60		50
2	15	34.2	F <sub>2T</sub> <sup>(8)</sup> (N)		8,482	8,482		8,168	8,168	2,199	1,571		3,456
			T <sub>2B</sub> <sup>(9)</sup> (Nm)		135	135		130	130	35	25		55
	16	36.4	F <sub>2T</sub> <sup>(8)</sup> (N)		9,130	9,130		8,541	8,541	2,651	1,767		4,418
			T <sub>2B</sub> <sup>(9)</sup> (Nm)		155	155		145	145	45	30		75
	18	40.2	F <sub>2T</sub> <sup>(8)</sup> (N)		10,472	10,472		8,901	8,901	3,665	2,094		4,974
			T <sub>2B</sub> <sup>(9)</sup> (Nm)		200	200		170	170	70	40		95
	20	44.4	F <sub>2T</sub> <sup>(8)</sup> (N)		9,896	9,896		8,247	8,247	2,356	1,649		4,006
			T <sub>2B</sub> <sup>(9)</sup> (Nm)		210	210		175	175	50	35		85
	22	48.6	F <sub>2T</sub> <sup>(8)</sup> (N)		9,853	9,853		8,354	8,354	2,999	1,714		4,070
			T <sub>2B</sub> <sup>(9)</sup> (Nm)		230	230		195	195	70	40		95
	23	50.8	F <sub>2T</sub> <sup>(8)</sup> (N)		10,039	10,039		8,195	8,195	3,278	1,843		3,893
			T <sub>2B</sub> <sup>(9)</sup> (Nm)		245	245		200	200	80	45		95
	25	53.052	F <sub>2T</sub> <sup>(8)</sup> (N)		10,744	10,744		8,859	8,859	4,712	2,262		4,524
			T <sub>2B</sub> <sup>(9)</sup> (Nm)		285	285		235	235	125	60		120
	25	55	F <sub>2T</sub> <sup>(8)</sup> (N)		9,990	9,990		8,294	8,294	3,958	2,073		3,958
			T <sub>2B</sub> <sup>(9)</sup> (Nm)		265	265		220	220	105	55		105
	27	58.8	F <sub>2T</sub> <sup>(8)</sup> (N)		10,297	10,297		8,552	8,552	4,887	2,269		3,840
			T <sub>2B</sub> <sup>(9)</sup> (Nm)		295	295		245	245	140	65		110
3	20	66.4	F <sub>2T</sub> <sup>(8)</sup> (N)		18,378	18,378		15,551	15,551	6,754	3,142		10,681
			T <sub>2B</sub> <sup>(9)</sup> (Nm)		585	585		495	495	215	100		340
	22	72.8	F <sub>2T</sub> <sup>(8)</sup> (N)		18,564	18,564		15,708	15,708	8,140	3,998		10,567
			T <sub>2B</sub> <sup>(9)</sup> (Nm)		650	650		550	550	285	140		370
	24	79.2	F <sub>2T</sub> <sup>(8)</sup> (N)		18,588	18,588		15,708	15,708	9,687	4,974		10,603
			T <sub>2B</sub> <sup>(9)</sup> (Nm)		710	710		600	600	370	190		405
4	20	88.08	F <sub>2T</sub> <sup>(8)</sup> (N)		33,340		28,628	28,628	28,628	14,726	7,304		20,381
			T <sub>2B</sub> <sup>(9)</sup> (Nm)		1,415		1,215	1,215	1,215	625	310		865
	25	108.82	F <sub>2T</sub> <sup>(8)</sup> (N)		34,118		29,311	29,217	29,217	21,865	12,064		20,546
			T <sub>2B</sub> <sup>(9)</sup> (Nm)		1,810		1,555	1,550	1,550	1,160	640		1,090
5	24	130.8	F <sub>2T</sub> <sup>(8)</sup> (N)	46,731	54,271		46,731	46,653	46,653		20,656		36,521
			T <sub>2B</sub> <sup>(9)</sup> (Nm)	2,975	3,455		2,975	2,970	2,970		1,315		2,325

\* The Maximal Driving Torque is also to be understood as the Maximal Acceleration Torque T<sub>2B</sub>.

The Emergency Stop Torque T<sub>2NOT</sub> = 2 × T<sub>2B</sub>, under the condition limited 1000 times in the whole service period.

(1) Number of Teeth    (5) Working Pitch Circle Diameter (in mm)    (8) Maximum Feed-Force    (9) Maximum Driving Torque

# Pinion with Helical Teeth

( Interface : Keyway for APEX AF- / PII-Series )

Quality DIN 5 / Alloy Steel

Tooth Thickness Tolerance : e25

Left-Hand Helical Teeth

Case-Hardened and Teeth Ground

Combine with AF Series gearbox

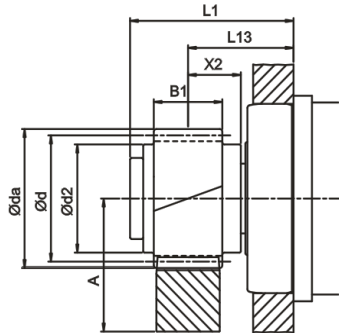

Gearbox	Mn	z <sup>(1)</sup>	x <sup>(2)</sup>	da <sup>(3)</sup>	d <sup>(4)</sup>	dw <sup>(5)</sup>	d2	B1	L1	L13	X2	L <sup>(6)</sup>	Order code
AF/AFR KF 060	2	18	0.401	43.8	38.197	39.8	30	26	54	39	19	120.000	E02L18
AF/AFR KF 075	2	22	0.179	51.4	46.686	47.4	40	26	62	40	20	146.667	E02L22
AF/AFR KF 100	2	26	0.007	59.2	55.174	55.2	46	26	96	51	21	173.334	E02L26
AF/AFR KF 140	3	24	0.001	82.4	76.394	76.4	62	31	122	65.5	35.5	240.000	E03L24

Combine with PEII Series gearbox

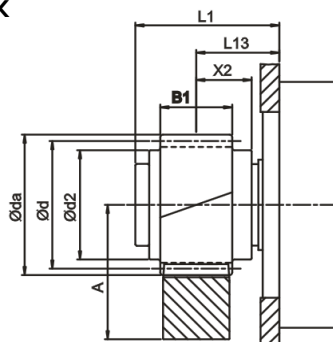

Gearbox	Mn	z <sup>(1)</sup>	x <sup>(2)</sup>	da <sup>(3)</sup>	d <sup>(4)</sup>	dw <sup>(5)</sup>	d2	B1	L1	L13	X2	L <sup>(6)</sup>	Order code
PEII 070 PEIIR 070	2	18	0.401	43.8	38.197	39.8	30	26	42	27	19	120.000	E02L18
PEII 090 PEIIR 090	2	22	0.179	51.4	46.686	47.4	40	26	52	30	20	146.667	E02L22
PEII 120 PEIIR 120	2	26	0.007	59.2	55.174	55.2	46	26	78	33	21	173.334	E02L26
PEII 155 PEIIR 155	3	24	0.001	82.4	76.394	76.4	62	31	107	50.5	35.5	240.000	E03L24

(1) Number of teeth (2) Profile modification factor (3) Diameter of addendum circle (4) Pitch circle diameter  
(5) Working pitch circle diameter (6) Pitch circle length  $L = \pi \times d$

Pinion material carburized, the surface hardness reaches to 60 HRC after case hardening

Teeth surface ground in order to reduce noise and improve wear resistance

Accessories include hexagon socket head cap screws ( Strength 12.9 , DIN 912 )



# Pinion with Helical Teeth

( Interface : Keyway )

Quality DIN 5 / Alloy Steel  
 Tooth Thickness Tolerance : e25  
 Left-Hand Helical Teeth  
 Case-Hardened and Teeth Ground

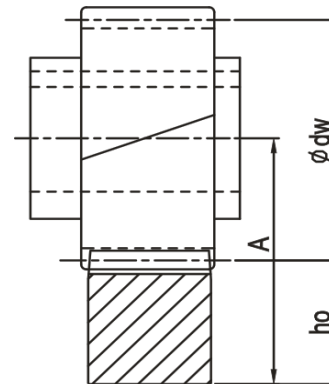
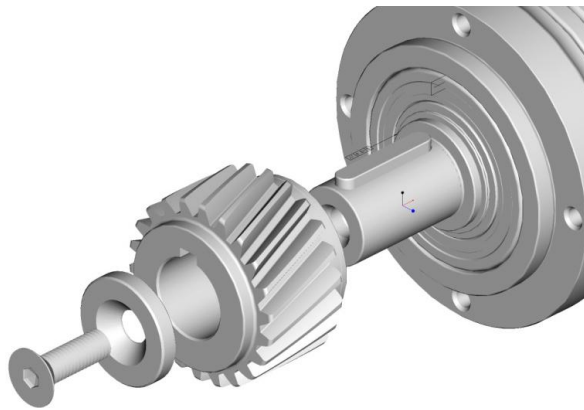

$$A = h_o + \frac{\phi dw}{2}$$

In table 5, the maximum permissible torque of pinion with Keyway for APEX AF-/PII-Gearbox, and the rack is calculated on the basis of a speed of 1.5 m/s and providing good lubrication (using an automatic lubrication system or manually applied grease every day), the tooth root strength factor  $S_F \geq 1.4$ , tooth surface strength coefficient  $S_H \geq 1$ , the safety factor  $S_B \approx 1$ , and the required service life of 20,000 hours. By higher speed, the max. permissible torque reduced. The user needs to increase the safety factor for the application. Backlash changes by different center height. Please contact APEX under WWW.APEXDYNA.COM.

Table 5, the max. permitted torque and feed-force of pinion with Keyway for APEX AF- / PII-Series

Pinion			Rack										
			Quality	Q4	Q5H	Q5		Q6	Q6M	Q8H	Q8	Q9	Q10
			Material	Carbon Steel	Alloy Steel		Carbon Steel	Carbon Steel	Carbon Steel	Q&T Alloy Steel	Carbon Steel	Stainless Steel	Carbon Steel
			Heat Treatment	Induction Hardening	Case Hardening	Carburized Induction	Induction Hardening	Induction Hardening	Induction Hardening	Quenched Tempered	Normalizing	Solution	Induction Hardening
Mn	z <sup>(1)</sup>	dw <sup>(5)</sup>	Max. Torque * and Feed-Force										
2	18	39.8	F <sub>2T</sub> <sup>(8)</sup> (N)		10,734	10,734		9,163	9,163	3,665	2,094		4,974
			T <sub>2B</sub> <sup>(9)</sup> (Nm)		205	205		175	175	70	40		95
	22	47.4	F <sub>2T</sub> <sup>(8)</sup> (N)		10,496	10,496		8,568	8,568	3,213	1,928		4,284
			T <sub>2B</sub> <sup>(9)</sup> (Nm)		245	245		200	200	75	45		100
	26	55.2	F <sub>2T</sub> <sup>(8)</sup> (N)		10,693	10,693		8,881	8,881	4,894	2,356		4,350
			T <sub>2B</sub> <sup>(9)</sup> (Nm)		295	295		245	245	135	65		120
3	24	76.4	F <sub>2T</sub> <sup>(8)</sup> (N)		19,635	19,635		16,624	16,624	10,864	5,760		11,650
			T <sub>2B</sub> <sup>(9)</sup> (Nm)		750	750		635	635	415	220		445

\* The Maximal Driving Torque is also to be understood as the Maximal Acceleration Torque T<sub>2B</sub>.

The Emergency Stop Torque T<sub>2NOT</sub> = 2 x T<sub>2B</sub>, under the condition limited 1000 times in the whole service period.

(1) Number of Teeth (5) Working Pitch Circle Diameter (in mm) (8) Maximum Feed-Force (9) Maximum Driving Torque

# Pinion with Helical Teeth ( Interface : Keyway )

Quality DIN 5 / Alloy Steel  
Tooth Thickness Tolerance : e25 \*  
Left-Hand Helical Teeth  
Case-Hardened and Teeth Ground

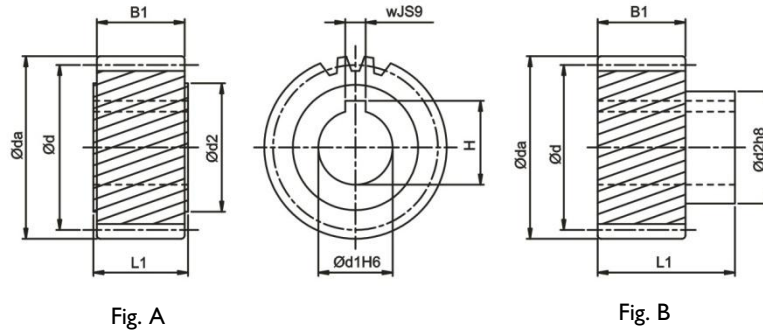

## Module 1.5

z <sup>(1)</sup>	x <sup>(2)</sup>	da <sup>(3)</sup>	d <sup>(4)</sup>	dw <sup>(5)</sup>	dl <sub>H6</sub>	d2	B1	L1	w <sub>JS9</sub>	H	L <sup>(6)</sup>	Fig	Order code	
													Pinion	Shrink Disc
20	0	34.831	31.831	31.831	11	25	20	22	4	12.8	100	A	FIJL20A11	
20	0	34.831	31.831	31.831	14	25	20	22	5	16.3	100	A	FIJL20A14	
20	0	34.831	31.831	31.831	16	25	20	22	5	18.3	100	A	FIJL20A16	
21	0	36.423	33.423	33.423	16	30	20	46	5	18.3	105	B	FIJL21B16	SSD-30

## Module 2

z <sup>(1)</sup>	x <sup>(2)</sup>	da <sup>(3)</sup>	d <sup>(4)</sup>	dw <sup>(5)</sup>	dl <sub>H6</sub>	d2	B1	L1	w <sub>JS9</sub>	H	L <sup>(6)</sup>	Fig	Order code	
													Pinion	Shrink Disc
18	0	42.197	38.197	38.197	16	25	28	30	5	18.3	120	A	F02L18A16	
20	0	46.441	42.441	42.441	19	30	28	30	6	21.8	133.334	A	F02L20A19	
20	0	46.441	42.441	42.441	19	30	28	56	6	21.8	133.334	B	F02L20B19	SSD-30
20	0	46.441	42.441	42.441	20	30	28	30	6	22.8	133.334	A	F02L20A20	
20	0	46.441	42.441	42.441	22	30	28	30	6	24.8	133.334	A	F02L20A22	
20	0	46.441	42.441	42.441	22	36	28	56	6	24.8	133.334	B	F02L20B22	SSD-36
21	0	48.563	44.563	44.563	16	25	28	30	5	18.3	140	A	F02L21A16	
21	0	48.563	44.563	44.563	22	36	28	56	6	24.8	140	B	F02L21B22	SSD-36
22	0	50.686	46.686	46.686	19	30	28	30	6	21.8	146.667	A	F02L22A19	
22	0	50.686	46.686	46.686	19	30	28	56	6	21.8	146.667	B	F02L22B19	SSD-30
22	0	50.686	46.686	46.686	22	30	28	30	6	24.8	146.667	A	F02L22A22	
22	0	50.686	46.686	46.686	22	36	28	56	6	24.8	146.667	B	F02L22B22	SSD-36
25	0	57.052	53.052	53.052	19	30	28	30	6	21.8	166.667	A	F02L25A19	
25	0	57.052	53.052	53.052	19	30	28	56	6	21.8	166.667	B	F02L25B19	SSD-30
25	0	57.052	53.052	53.052	20	30	28	30	6	22.8	166.667	A	F02L25A20	
25	0	57.052	53.052	53.052	22	30	28	30	6	24.8	166.667	A	F02L25A22	
25	0	57.052	53.052	53.052	22	36	28	56	6	24.8	166.667	B	F02L25B22	SSD-36
25	0	57.052	53.052	53.052	25	36	28	30	8	28.3	166.667	A	F02L25A25	

\* By Module 1.5, the Tooth Thickness Tolerance = f 24.

(1) Number of teeth (2) Profile modification factor (3) Diameter of addendum circle (4) Pitch circle diameter  
(5) Working pitch circle diameter (6) Pitch circle length  $L = \pi \times d$

Quality DIN 5 / Alloy Steel  
 Tooth Thickness Tolerance : e25  
 Left-Hand Helical Teeth  
 Case-Hardened and Teeth Ground

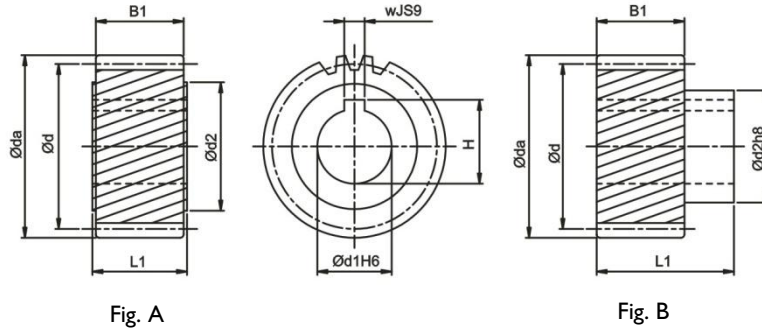

Module 2

z <sup>(1)</sup>	x <sup>(2)</sup>	da <sup>(3)</sup>	d <sup>(4)</sup>	dw <sup>(5)</sup>	dI <sub>H6</sub>	d2	B1	L1	w <sub>JS9</sub>	H	L <sup>(6)</sup>	Fig	Order code	
													Pinion	Shrink Disc
28	0	63.418	59.418	59.418	19	30	28	30	6	21.8	186.667	A	F02L28A19	
28	0	63.418	59.418	59.418	19	30	28	56	6	21.8	186.667	B	F02L28B19	SSD-30
28	0	63.418	59.418	59.418	22	30	28	30	6	24.8	186.667	A	F02L28A22	
28	0	63.418	59.418	59.418	22	36	28	56	6	24.8	186.667	B	F02L28B22	SSD-36
28	0	63.418	59.418	59.418	35	48	28	30	10	38.3	186.667	A	F02L28A35	
30	0	67.662	63.662	63.661	16	25	28	30	5	18.3	200	A	F02L30A16	
30	0	67.662	63.662	63.661	20	30	28	30	6	22.8	200	A	F02L30A20	
30	0	67.662	63.662	63.661	22	36	28	56	6	24.8	200	B	F02L30B22	SSD-36
30	0	67.662	63.662	63.661	25	36	28	30	8	28.3	200	A	F02L30A25	
30	0	67.662	63.662	63.661	30	45	28	30	8	33.3	200	A	F02L30A30	
30	0	67.662	63.662	63.661	30	50	28	60	8	33.3	200	B	F02L30B30	SSD-50
30	0	67.662	63.662	63.661	32	55	28	65	10	35.3	200	B	F02L30B32	SSD-55
32	0	71.906	67.906	67.906	20	30	28	30	6	22.8	213.334	A	F02L32A20	
32	0	71.906	67.906	67.906	22	30	28	30	6	24.8	213.334	A	F02L32A22	
32	0	71.906	67.906	67.906	22	36	28	56	6	24.8	213.334	B	F02L32B22	SSD-36
32	0	71.906	67.906	67.906	25	36	28	30	8	28.3	213.334	A	F02L32A25	
32	0	71.906	67.906	67.906	35	48	28	30	10	38.3	213.334	A	F02L32A35	
36	0	80.394	76.394	76.394	35	48	28	30	10	38.3	240	A	F02L36A35	
39	0	86.761	82.761	82.761	32	55	28	65	10	35.3	260	B	F02L39B32	SSD-55
40	0	88.883	84.883	84.883	35	48	28	30	10	38.3	266.667	A	F02L40A35	

Module 2.5

z <sup>(1)</sup>	x <sup>(2)</sup>	da <sup>(3)</sup>	d <sup>(4)</sup>	dw <sup>(5)</sup>	dI <sub>H6</sub>	d2	B1	L1	w <sub>JS9</sub>	H	L <sup>(6)</sup>	Fig	Order code	
													Pinion	Shrink Disc
24	0	68.662	63.662	63.662	25	36	28	30	8	28.3	200	A	F2JL24A25	
24	0	68.662	63.662	63.662	25	44	28	60	8	28.3	200	B	F2JL24B25	SSD-44

# Pinion with Helical Teeth ( Interface : Keyway )

Quality DIN 5 / Alloy Steel  
Tooth Thickness Tolerance : e25  
Left-Hand Helical Teeth  
Case-Hardened and Teeth Ground

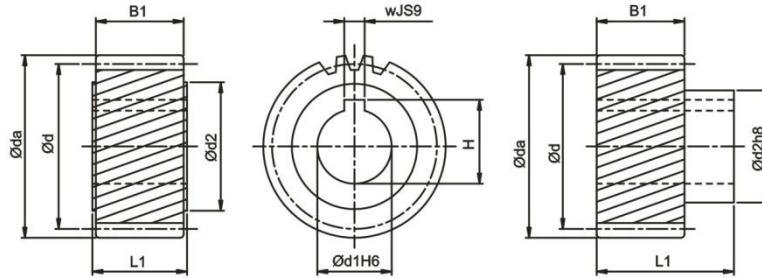

Fig. A

Fig. B

## Module 3

z <sup>(1)</sup>	x <sup>(2)</sup>	da <sup>(3)</sup>	d <sup>(4)</sup>	dw <sup>(5)</sup>	d1 <sub>H6</sub>	d2	B1	L1	w <sub>JS9</sub>	H	L <sup>(6)</sup>	Fig	Order code	
													Pinion	Shrink Disc
20	0	69.661	63.662	63.662	22	36	28	56	6	24.8	200	B	F03L20B22	SSD-36
20	0	69.661	63.662	63.662	25	44	28	60	8	28.3	200	B	F03L20B25	SSD-44
20	0	69.661	63.662	63.662	30	45	28	30	8	33.3	200	A	F03L20A30	
20	0	69.661	63.662	63.662	30	50	28	60	8	33.3	200	B	F03L20B30	SSD-50
20	0	69.661	63.662	63.662	32	55	28	65	10	35.3	200	B	F03L20B32	SSD-55
20	0	69.661	63.662	63.662	35	48	28	30	10	38.3	200	A	F03L20A35	
22	0	76.028	70.028	70.028	25	36	28	30	8	28.3	220	A	F03L22A25	
22	0	76.028	70.028	70.028	30	45	28	30	8	33.3	220	A	F03L22A30	
22	0	76.028	70.028	70.028	32	55	28	65	10	35.3	220	B	F03L22B32	SSD-55
22	0	76.028	70.028	70.028	35	48	28	30	10	38.3	220	A	F03L22A35	
22	0	76.028	70.028	70.028	40	62	28	65	12	43.3	220	B	F03L22B40	SSD-62
25	0	85.578	79.578	79.578	22	36	28	56	6	24.8	250	B	F03L25B22	SSD-36
25	0	85.578	79.578	79.578	25	44	28	60	8	28.3	250	A	F03L25A25	
25	0	85.578	79.578	79.578	25	44	28	60	8	28.3	250	B	F03L25B25	SSD-44
25	0	85.578	79.578	79.578	30	45	28	30	8	33.3	250	A	F03L25A30	
25	0	85.578	79.578	79.578	30	50	28	60	8	33.3	250	B	F03L25B30	SSD-50
25	0	85.578	79.578	79.578	32	55	28	65	10	35.3	250	B	F03L25B32	SSD-55
25	0	85.578	79.578	79.578	35	48	28	30	10	38.3	250	A	F03L25A35	
25	0	85.578	79.578	79.578	35	55	28	65	10	38.3	250	B	F03L25B35	SSD-55
25	0	85.578	79.578	79.578	40	62	28	65	12	43.3	250	B	F03L25B40	SSD-62
25	0	85.578	79.578	79.578	40	70	28	50	12	43.3	250	A	F03L25A40	
28	0	95.127	89.127	89.127	32	55	28	65	10	35.3	280	B	F03L28B32	SSD-55
28	0	95.127	89.127	89.127	40	62	28	65	12	43.3	280	B	F03L28B40	SSD-62
32	0	107.859	101.859	101.859	32	55	28	65	10	35.3	320	B	F03L32B32	SSD-55
32	0	107.859	101.859	101.859	40	62	28	65	12	43.3	320	B	F03L32B40	SSD-62

## Module 4

z <sup>(1)</sup>	x <sup>(2)</sup>	da <sup>(3)</sup>	d <sup>(4)</sup>	dw <sup>(5)</sup>	d1 <sub>H6</sub>	d2	B1	L1	w <sub>JS9</sub>	H	L <sup>(6)</sup>	Fig	Order code	
													Pinion	Shrink Disc
15	0	71.662	63.662	63.662	35	52	40	50	10	38.3	200.000	A	F04L15A35	
18	0	84.394	76.394	76.394	32	55	40	75	10	35.3	240.000	B	F04L18B32	SSD-55
20	0	92.883	84.883	84.883	35	52	40	50	10	38.3	266.667	A	F04L20A35	
20	0	92.883	84.883	84.883	45	65	40	50	14	48.8	266.667	A	F04L20A45	
21	0	97.127	89.127	89.127	32	55	40	75	10	35.3	280.000	B	F04L21B32	SSD-55
21	0	97.127	89.127	89.127	35	55	40	75	10	38.3	280.000	B	F04L21B35	SSD-55
21	0	97.127	89.127	89.127	40	62	40	75	12	43.3	280.000	B	F04L21B40	SSD-62
21	0	97.127	89.127	89.127	45	68	40	75	14	48.8	280.000	B	F04L21B45	SSD-68

(1) Number of teeth (2) Profile modification factor (3) Diameter of addendum circle (4) Pitch circle diameter  
(5) Working pitch circle diameter (6) Pitch circle length  $L = \pi \times d$

Quality DIN 5 / Alloy Steel  
 Tooth Thickness Tolerance : e25  
 Left-Hand Helical Teeth  
 Case-Hardened and Teeth Ground

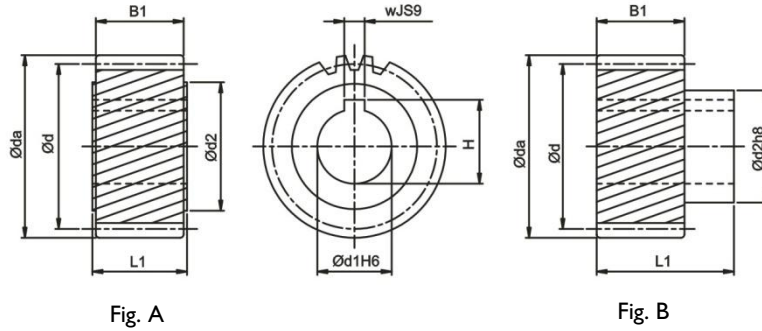

Module 4

z <sup>(1)</sup>	x <sup>(2)</sup>	da <sup>(3)</sup>	d <sup>(4)</sup>	dw <sup>(5)</sup>	d1 <sub>H6</sub>	d2	B1	L1	w <sub>JS9</sub>	H	L <sup>(6)</sup>	Fig	Order code	
													Pinion	Shrink Disc
22	0	101.371	93.371	93.371	35	52	40	50	10	38.3	293.334	A	F04L22A35	
22	0	101.371	93.371	93.371	45	65	40	50	14	48.8	293.334	A	F04L22A45	
24	0	109.859	101.859	101.859	32	55	40	75	10	35.3	320.000	B	F04L24B32	SSD-55
24	0	109.859	101.859	101.859	35	55	40	75	10	38.3	320.000	B	F04L24B35	SSD-55
24	0	109.859	101.859	101.859	40	62	40	75	12	43.3	320.000	B	F04L24B40	SSD-62
24	0	109.859	101.859	101.859	45	68	40	75	14	48.8	320.000	B	F04L24B45	SSD-68
24	0	109.859	101.859	101.859	55	80	40	80	16	59.3	320.000	B	F04L24B55	SSD-80
25	0	114.103	106.103	106.103	35	52	40	50	10	38.3	333.334	A	F04L25A35	
25	0	114.103	106.103	106.103	45	65	40	50	14	48.8	333.334	A	F04L25A45	
25	0	114.103	106.103	106.103	55	80	40	80	16	59.3	333.334	B	F04L25B55	SSD-80

Module 5

z <sup>(1)</sup>	x <sup>(2)</sup>	da <sup>(3)</sup>	d <sup>(4)</sup>	dw <sup>(5)</sup>	d1 <sub>H6</sub>	d2	B1	L1	w <sub>JS9</sub>	H	L <sup>(6)</sup>	Fig	Order code	
													Pinion	Shrink Disc
18	0	105.493	95.493	95.493	45	68	50	85	14	48.8	300	B	F05L18B45	SSD-68
24	0	137.324	127.324	127.324	45	68	50	85	14	48.8	400	B	F05L24B45	SSD-68
24	0	137.324	127.324	127.324	55	80	50	90	16	59.3	400	B	F05L24B55	SSD-80
24	0	137.324	127.324	127.324	75	110	50	110	20	79.9	400	B	F05L24B75	SSD-110

Module 6

z <sup>(1)</sup>	x <sup>(2)</sup>	da <sup>(3)</sup>	d <sup>(4)</sup>	dw <sup>(5)</sup>	d1 <sub>H6</sub>	d2	B1	L1	w <sub>JS9</sub>	H	L <sup>(6)</sup>	Fig	Order code	
													Pinion	Shrink Disc
20	0	139.324	127.324	127.324	55	80	60	100	16	59.3	400	B	F06L20B55	SSD-80
20	0	139.324	127.324	127.324	75	110	60	120	20	79.9	400	B	F06L20B75	SSD-110
25	0	171.155	159.155	159.155	55	80	60	100	16	59.3	500	B	F06L25B55	SSD-80
25	0	171.155	159.155	159.155	75	110	60	120	20	79.9	500	B	F06L25B75	SSD-110

# Pinion with Helical Teeth

( Interface : Keyway )

Quality DIN 5 / Alloy Steel  
 Tooth Thickness Tolerance : e25 \*\*  
 Left-Hand Helical Teeth  
 Case-Hardened and Teeth Ground

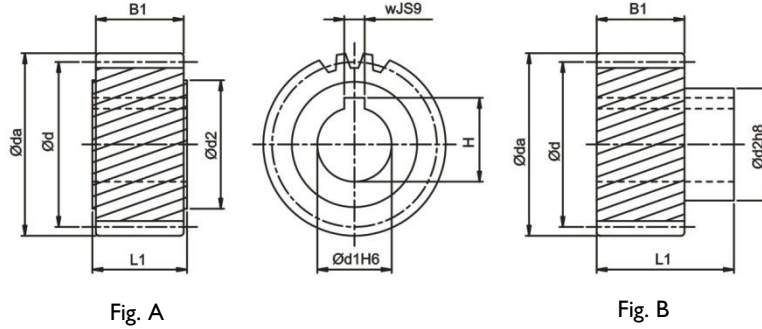

## Module 8

z <sup>(1)</sup>	x <sup>(2)</sup>	da <sup>(3)</sup>	d <sup>(4)</sup>	dw <sup>(5)</sup>	d1 <sub>H6</sub>	d2	B1	L1	w <sub>JS9</sub>	H	L <sup>(6)</sup>	Fig	Order code	
													Pinion	Shrink Disc
18	0	168.789	152.789	152.789	75	110	80	140	20	79.9	480.000	B	F08L18B75	SSD-110
20	0	185.766	169.766	169.766	85	125	80	145	22	90.4	533.334	B	F08L20B85	SSD-125

## Module 10

z <sup>(1)</sup>	x <sup>(2)</sup>	da <sup>(3)</sup>	d <sup>(4)</sup>	dw <sup>(5)</sup>	d1 <sub>H6</sub>	d2	B1	L1	w <sub>JS9</sub>	H	L <sup>(6)</sup>	Fig	Order code	
													Pinion	Shrink Disc
20	0	232.207	212.207	212.207	85	125	100	165	22	90.4	666.668	B	F10L20B85	SSD-125

\*\* By Module 8 and 10, the Tooth Thickness Tolerance = f 23. (1) Number of teeth (2) Profile modification factor  
 (3) Diameter of addendum circle (4) Pitch circle diameter (5) Working pitch circle diameter (6) Pitch circle length L = π x d

Pinion material carburized, the surface hardness reaches to 60 HRC after case hardening  
 Teeth surface ground in order to reduce noise and improve wear resistance

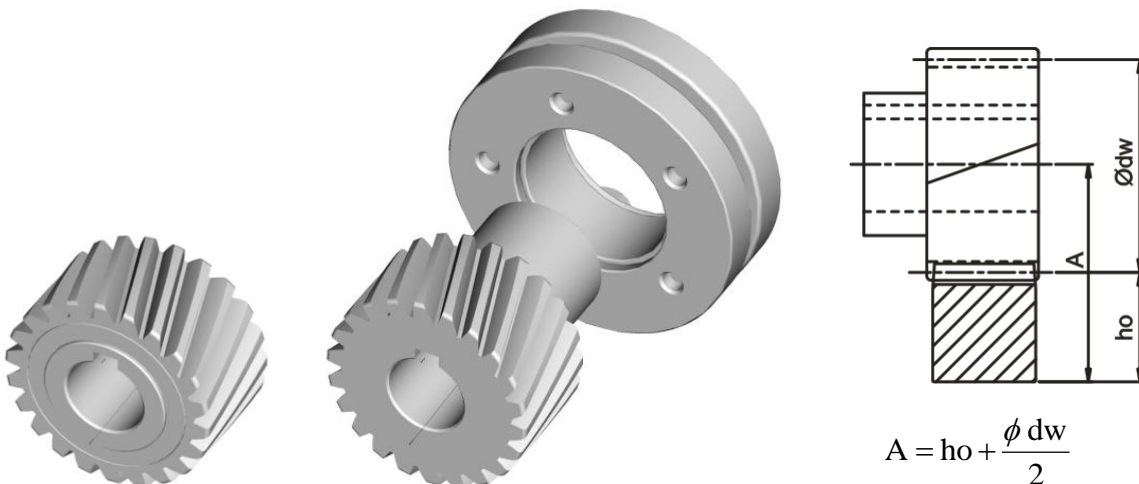

In Table 6, the maximum permissible torque of pinion with Keyway, and the rack is calculated on the basis of a speed of 1.5 m/s and providing good lubrication (using an automatic lubrication system or manually applied grease every day), the tooth root strength factor  $S_F \geq 1.4$ , tooth surface strength coefficient  $S_H \geq 1$ , the safety factor  $S_B \cong 1$ , and the required service life of 20,000 hours. By higher speed, the max. permissible torque reduced. The user needs to increase the safety factor for the application. Backlash changes by different center height. Please contact APEX under WWW.APEXDYNA.COM.

Table 6. The max. permitted torque and feed-force of pinion with Keyway

Pinion \ Rack			Quality	Q4	Q5H	Q5		Q6	Q6M	Q8H	Q8	Q9	Q10
			Material	Carbon Steel	Alloy Steel		Carbon Steel	Carbon Steel	Carbon Steel	Q&T Alloy Steel	Carbon Steel	Stainless Steel	Carbon Steel
			Heat Treatment	Induction Hardening	Case Hardening	Carburized Induction	Induction Hardening	Induction Hardening	Induction Hardening	Quenched Tempered	Normalizing	Solution	Induction Hardening
Mn	z <sup>(1)</sup>	dw <sup>(5)</sup>	Max. Torque * and Feed-Force										
1.5	20	31.831	F <sub>2T</sub> <sup>(8)</sup> (N)					5,027			628		1,257
			T <sub>2B</sub> <sup>(9)</sup> (Nm)					80			10		20
	21	33.423	F <sub>2T</sub> <sup>(8)</sup> (N)					5,086			598		1,197
			T <sub>2B</sub> <sup>(9)</sup> (Nm)					85			10		20
2	18	38.197	F <sub>2T</sub> <sup>(8)</sup> (N)		11,257	11,257		9,163	9,163	2,880	1,833		2,880
			T <sub>2B</sub> <sup>(9)</sup> (Nm)		215	215		175	175	55	35		55
	20	42.441	F <sub>2T</sub> <sup>(8)</sup> (N)		10,367	10,367		8,247	8,247	2,121	1,414		2,356
			T <sub>2B</sub> <sup>(9)</sup> (Nm)		220	220		175	175	45	30		50
	21	44.563	F <sub>2T</sub> <sup>(8)</sup> (N)		10,547	10,547		8,303	8,303	2,244	1,346		2,468
			T <sub>2B</sub> <sup>(9)</sup> (Nm)		235	235		185	185	50	30		55
	22	46.686	F <sub>2T</sub> <sup>(8)</sup> (N)		10,496	10,496		8,354	8,354	2,356	1,499		2,356
			T <sub>2B</sub> <sup>(9)</sup> (Nm)		245	245		195	195	55	35		55
	25	53.052	F <sub>2T</sub> <sup>(8)</sup> (N)		10,556	10,556		8,294	8,294	3,204	1,885		2,262
			T <sub>2B</sub> <sup>(9)</sup> (Nm)		280	280		220	220	85	50		60
	28	59.418	F <sub>2T</sub> <sup>(8)</sup> (N)		10,771	10,771		8,415	8,415	4,207	2,020		2,188
			T <sub>2B</sub> <sup>(9)</sup> (Nm)		320	320		250	250	125	60		65
	30	63.661	F <sub>2T</sub> <sup>(8)</sup> (N)		10,681	10,681		8,325	8,325	4,555	2,199		2,199
			T <sub>2B</sub> <sup>(9)</sup> (Nm)		340	340		265	265	145	70		70
	32	67.906	F <sub>2T</sub> <sup>(8)</sup> (N)		10,750	10,750		8,394	8,394	4,418	2,356		2,209
			T <sub>2B</sub> <sup>(9)</sup> (Nm)		365	365		285	285	150	80		75
	36	76.394	F <sub>2T</sub> <sup>(8)</sup> (N)		10,734	10,734		8,378	8,378	4,451	2,880		2,225
			T <sub>2B</sub> <sup>(9)</sup> (Nm)		410	410		320	320	170	110		85
	39	82.761	F <sub>2T</sub> <sup>(8)</sup> (N)		10,874	10,874		8,337	8,337	4,471	2,779		2,175
			T <sub>2B</sub> <sup>(9)</sup> (Nm)		450	450		345	345	185	115		90
40	84.883	F <sub>2T</sub> <sup>(8)</sup> (N)		10,838	10,838		8,364	8,364	4,477	2,827		2,238	
		T <sub>2B</sub> <sup>(9)</sup> (Nm)		460	460		355	355	190	120		95	
2.5	24	63.662	F <sub>2T</sub> <sup>(8)</sup> (N)			16,022		13,195	13,195	5,184	2,827		5,027
			T <sub>2B</sub> <sup>(9)</sup> (Nm)			510		420	420	165	90		160
3	20	63.662	F <sub>2T</sub> <sup>(8)</sup> (N)		18,535	18,535		16,493	16,493	5,341	2,356		8,796
			T <sub>2B</sub> <sup>(9)</sup> (Nm)		590	590		525	525	170	75		280
	22	70.028	F <sub>2T</sub> <sup>(8)</sup> (N)		18,850	18,850		16,565	16,565	6,712	2,713		8,568
			T <sub>2B</sub> <sup>(9)</sup> (Nm)		660	660		580	580	235	95		300
	25	79.578	F <sub>2T</sub> <sup>(8)</sup> (N)		19,227	19,227		16,588	16,588	8,922	3,770		8,419
			T <sub>2B</sub> <sup>(9)</sup> (Nm)		765	765		660	660	355	150		335
	28	89.127	F <sub>2T</sub> <sup>(8)</sup> (N)		19,523	19,523		16,606	16,606	10,883	5,161		8,303
			T <sub>2B</sub> <sup>(9)</sup> (Nm)		870	870		740	740	485	230		370
32	101.859	F <sub>2T</sub> <sup>(8)</sup> (N)		19,831	19,831		16,690	16,690	10,799	7,265		8,247	
		T <sub>2B</sub> <sup>(9)</sup> (Nm)		1,010	1,010		850	850	550	370		420	

\* The Maximal Driving Torque is also to be understood as the Maximal Acceleration Torque T<sub>2B</sub>.

The Emergency Stop Torque T<sub>2NOT</sub> = 2 × T<sub>2B</sub>, under the condition limited 1000 times in the whole service period.

(1) Number of Teeth (5) Working Pitch Circle Diameter (in mm) (8) Maximum Feed-Force (9) Maximum Driving Torque

# Pinion with Helical Teeth ( Interface : Keyway )

Table 6. The max. permitted torque and feed-force of pinion with Keyway

Pinion \ Rack			Quality	Q4	Q5H	Q5		Q6	Q6M	Q8H	Q8	Q9	Q10	
			Material	Carbon Steel	Alloy Steel		Carbon Steel	Carbon Steel	Carbon Steel	Carbon Steel	Q&T Alloy Steel	Carbon Steel	Stainless Steel	Carbon Steel
			Heat Treatment	Induction Hardening	Case Hardening	Carburized Induction	Induction Hardening	Induction Hardening	Induction Hardening	Induction Hardening	Quenched Tempered	Normalizing	Solution	Induction Hardening
Mn	z <sup>(1)</sup>	dw <sup>(5)</sup>	Max. Torque * and Feed-Force											
4	15	63.662	F <sub>2T</sub> <sup>(8)</sup> (N)		31,730		32,201	32,201	32,201	13,038	5,027		13,509	
			T <sub>2B</sub> <sup>(9)</sup> (Nm)		1,010		1,025	1,025	1,025	415	160		430	
	18	76.394	F <sub>2T</sub> <sup>(8)</sup> (N)		34,557		34,557	34,557	34,557	18,850	8,639		18,457	
			T <sub>2B</sub> <sup>(9)</sup> (Nm)		1,320		1,320	1,320	1,320	720	330		705	
	20	84.883	F <sub>2T</sub> <sup>(8)</sup> (N)		35,107		30,159	30,159	30,159	12,959	4,830		14,962	
			T <sub>2B</sub> <sup>(9)</sup> (Nm)		1,490		1,280	1,280	1,280	550	205		635	
	21	89.127	F <sub>2T</sub> <sup>(8)</sup> (N)		35,118		30,294	30,182	30,182	14,362	5,610		14,810	
			T <sub>2B</sub> <sup>(9)</sup> (Nm)		1,565		1,350	1,345	1,345	640	250		660	
	22	93.371	F <sub>2T</sub> <sup>(8)</sup> (N)		35,236		30,309	30,202	30,202	15,851	6,533		14,780	
			T <sub>2B</sub> <sup>(9)</sup> (Nm)		1,645		1,415	1,410	1,410	740	305		690	
	24	101.859	F <sub>2T</sub> <sup>(8)</sup> (N)		35,343		30,434	30,238	30,238	18,850	8,443		14,530	
			T <sub>2B</sub> <sup>(9)</sup> (Nm)		1,800		1,550	1,540	1,540	960	430		740	
	25	106.103	F <sub>2T</sub> <sup>(8)</sup> (N)		35,343		30,442	30,253	30,253	19,321	9,425		14,514	
			T <sub>2B</sub> <sup>(9)</sup> (Nm)		1,875		1,615	1,605	1,605	1,025	500		770	
5	18	95.493	F <sub>2T</sub> <sup>(8)</sup> (N)	54,140	54,140		54,140	54,035	54,035		18,012		35,081	
			T <sub>2B</sub> <sup>(9)</sup> (Nm)	2,585	2,585		2,585	2,580	2,580		860		1,575	
	24	127.324	F <sub>2T</sub> <sup>(8)</sup> (N)	48,538	56,470		48,538	48,538	48,538		18,064		28,588	
			T <sub>2B</sub> <sup>(9)</sup> (Nm)	3,090	3,595		3,090	3,090	3,090		1,150		1,820	
6	20	127.324	F <sub>2T</sub> <sup>(8)</sup> (N)	69,036	79,011		69,036	69,036	69,036		21,756		47,359	
			T <sub>2B</sub> <sup>(9)</sup> (Nm)	4,395	5,030		4,395	4,395	4,395		1,385		3,015	
	25	159.155	F <sub>2T</sub> <sup>(8)</sup> (N)	72,131	82,058		72,131	72,068	72,068		33,552		49,574	
			T <sub>2B</sub> <sup>(9)</sup> (Nm)	5,740	6,530		5,740	5,735	5,735		2,670		3,945	
8	18	152.789	F <sub>2T</sub> <sup>(8)</sup> (N)	134,368	134,368		134,368	134,368	134,368		62,832		99,876	
			T <sub>2B</sub> <sup>(9)</sup> (Nm)	10,265	10,265		10,265	10,265	10,265		4,800		7,630	
	20	169.766	F <sub>2T</sub> <sup>(8)</sup> (N)	126,527	136,188		126,527	126,527	126,527		46,122		93,423	
			T <sub>2B</sub> <sup>(9)</sup> (Nm)	10,740	11,560		10,740	10,740	10,740		3,915		7,930	
10	20	212.207	F <sub>2T</sub> <sup>(8)</sup> (N)	193,490	190,899		193,490	193,443	193,443		85,812		143,492	
			T <sub>2B</sub> <sup>(9)</sup> (Nm)	20,530	20,255		20,530	20,525	20,525		9,105		15,225	

\* The Maximal Driving Torque is also to be understood as the Maximal Acceleration Torque T<sub>2B</sub>.  
 The Emergency Stop Torque T<sub>2NOT</sub> = 2 x T<sub>2B</sub>, under the condition limited 1000 times in the whole service period.  
 (1) Number of Teeth    (5) Working Pitch Circle Diameter (in mm)    (8) Maximum Feed-Force    (9) Maximum Driving Torque



# Rack with Straight Teeth

Quality 4 / Carbon Steel  
 Tooth Thickness Tolerance :  $-13 \sim 0 \mu\text{m}$   
 Straight Teeth  
 Teeth Induction Hardened and Ground  
 All Sides Ground

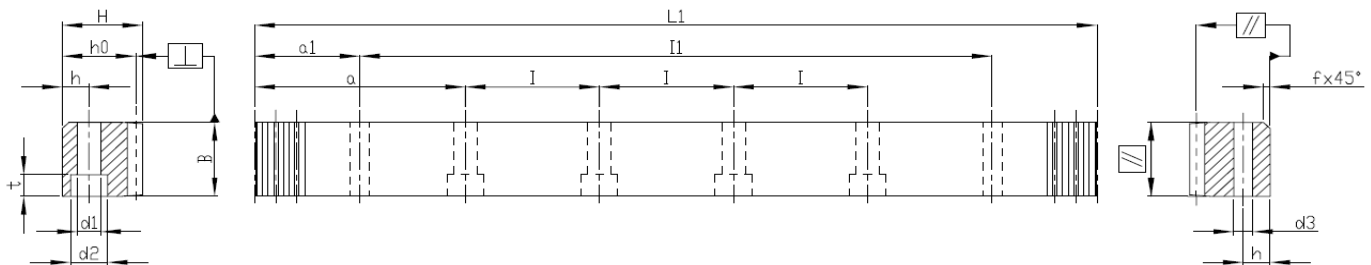

Mn	Pt <sup>(1)</sup>	L1	Teeth No.	B	H	h <sub>0</sub>	f	a	I	Hole No.	h	d1	d2	t	a1	II	d3	f <sub>p</sub> <sup>(2)</sup>	F <sub>p</sub> <sup>(3)</sup>	Order Code *
5	15.70796	1005.31	64	49	39	34	3	62.83	125.66	8	12	14	20	13	30.10	945.11	11.7	0.005	0.02	05041100C10
6	18.84956	1017.88	54	59	49	43	3	63.62	127.23	8	16	18	26	17	31.40	955.08	15.7	0.005	0.02	06041100C10
8	25.13274	1005.31	40	79	79	71	3	62.83	125.66	8	25	22	33	21	26.60	952.11	19.7	0.006	0.022	08041100C10
10	31.41593	1005.31	32	99	99	89	3	62.83	125.66	8	32	33	48	32	125.66	753.99	19.7	0.006	0.022	10041100C10
12	37.69911	1017.88	27	120	120	108	3	63.62	127.23	8	40	39	58	38	127.23	763.42	19.7	0.007	0.023	12041100C10

(1) Teeth Pitch  $Pt = \text{Module} \times \pi$     (2)  $f_p = \text{Single Pitch Error}$     (3)  $F_p = \text{Total Pitch Error}$

\* For all models APEX also provides Rack without screw-holes. By ordering please change the 2nd last order-code position from "1" to "0". Please also refer to page 14.

# Rack with Straight Teeth

Quality 5H / Alloy Steel  
 Tooth Thickness Tolerance : -15 ~ 0  $\mu\text{m}$   
 Straight Teeth  
 Material Case-Hardened  
 Teeth Ground and all Sides Ground

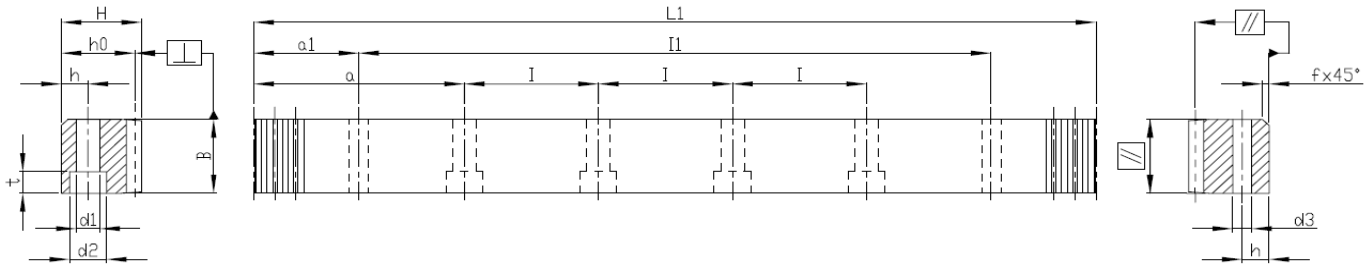

Mn	Pt <sup>(1)</sup>	LI	Teeth No.	B	H	h <sub>0</sub>	f	a	I	Hole No.	h	d1	d2	t	a1	I1	d3	f <sub>p</sub> <sup>(2)</sup>	F <sub>p</sub> <sup>(3)</sup>	Order Code *
2	6.28319	1005.31	160	24	24	22	2	62.83	125.66	8	9	10	15	9	31.30	942.70	7.7	0.006	0.024	025H1100M10
3	9.42478	1017.88	108	29	29	26	2	63.62	127.23	8	10	12	17.5	11	28.60	960.60	11.7	0.006	0.026	035H1100M10
4	12.56637	1005.31	80	39	39	35	3	62.83	125.66	8	13	16	23	15	30.30	944.70	15.7	0.007	0.028	045H1100M10
5	15.70796	1005.31	64	49	49	44	3	62.83	125.66	8	15	18	26	17	34.80	935.70	15.7	0.007	0.028	055H1100M10
6	18.84956	1017.88	54	59	59	53	3	63.62	127.23	8	20	22	33	21	98.60	820.60	19.7	0.007	0.028	065H1100M10
8	25.13274	1005.31	40	79	79	71	3	62.83	125.66	8	25	26	39	25	26.60	952.11	19.7	0.008	0.031	085H1100M10
10	31.41593	1005.31	32	99	99	89	3	62.83	125.66	8	32	39	58	38	125.66	753.99	19.7	0.008	0.031	105H1100M10

(1) Teeth Pitch Pt = Module  $\times \pi$     (2) f<sub>p</sub> = Single Pitch Error    (3) F<sub>p</sub> = Total Pitch Error

\* For all models APEX also provides Rack without screw-holes. By ordering please change the 2nd last order-code position from "1" to "0". Please also refer to page 14.

Especially for the application without back-support.

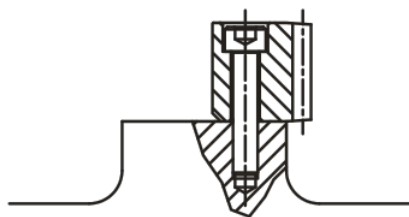

Without alignment / back-support

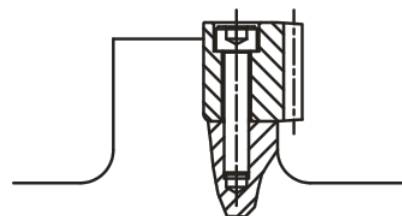

With alignment / back-support

**Quality 5 / Alloy Steel**  
**Tooth Thickness Tolerance : -15 ~ 0 μm**  
**Straight Teeth**  
**Material Carburized, Induction Hardened**  
**Teeth Ground and all Sides Ground**

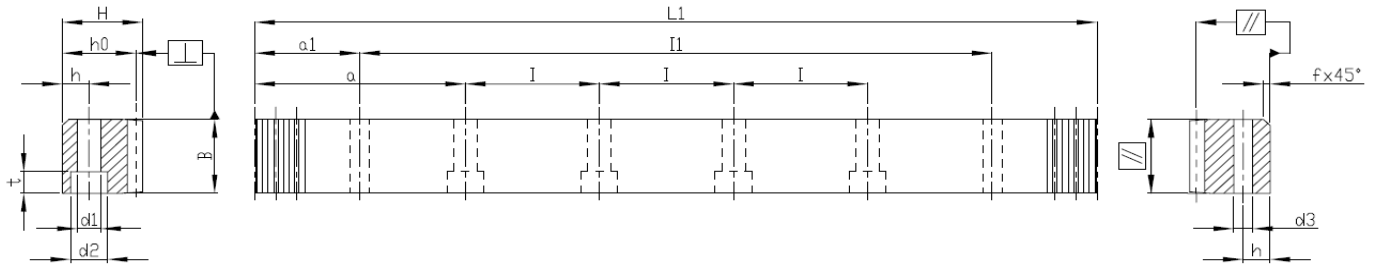

Mn	Pt <sup>(1)</sup>	L1	Teeth No.	B	H	ho	f	a	I	Hole No.	h	d1	D2	T	a1	I1	d3	f <sub>p</sub> <sup>(2)</sup>	F <sub>p</sub> <sup>(3)</sup>	Order Code*
2	6.28319	251.33	40	24	24	22	2	62.83	125.66	2	8	7	11	7	31.3	188.73	5.7	0.005	0.018	02051025M10
2	6.28319	502.66	80	24	24	22	2	62.83	125.66	4	8	7	11	7	31.3	440.06	5.7	0.006	0.021	02051050M10
2	6.28319	1005.31	160	24	24	22	2	62.83	125.66	8	8	7	11	7	31.3	942.71	5.7	0.006	0.024	02051100M10
3	9.42478	254.47	27	29	29	26	2	63.62	127.23	2	9	10	15	9	34.4	185.67	7.7	0.006	0.019	03051025M10
3	9.42478	508.94	54	29	29	26	2	63.62	127.23	4	9	10	15	9	34.4	440.14	7.7	0.006	0.023	03051050M10
3	9.42478	1017.88	108	29	29	26	2	63.62	127.23	8	9	10	15	9	34.4	949.08	7.7	0.006	0.026	03051100M10

(1) Teeth Pitch Pt = Module x π    (2) fp = Single Pitch Error    (3) Fp = Total Pitch Error

\* For all models APEX also provides Rack without screw-holes. By ordering please change the 2nd last order-code position from "1" to "0". Please also refer to page 14.

# Rack with Straight Teeth

Quality 5 / Carbon Steel  
 Tooth Thickness Tolerance : -15 ~ 0  $\mu\text{m}$   
 Straight Teeth  
 Teeth Induction Hardened and Ground  
 All Sides Ground

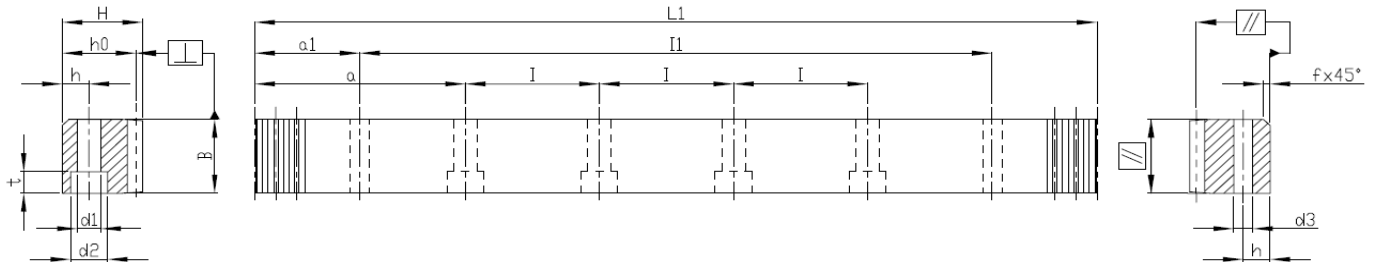

Mn	Pt <sup>(1)</sup>	L1	Teeth No.	B	H	ho	f	a	l	Hole No.	h	d1	d2	t	a1	l1	d3	f <sub>p</sub> <sup>(2)</sup>	F <sub>p</sub> <sup>(3)</sup>	Order Code*
4	12.56637	251.33	20	39	39	35	3	62.83	125.66	2	12	10	15	9	37.5	176.33	7.7	0.006	0.021	04051025C10
4	12.56637	502.66	40	39	39	35	3	62.83	125.66	4	12	10	15	9	37.5	427.66	7.7	0.007	0.026	04051050C10
4	12.56637	1005.31	80	39	39	35	3	62.83	125.66	8	12	10	15	9	37.5	930.31	7.7	0.007	0.028	04051100C10
4	12.56637	1005.31	80	39	39	35	3	62.83	125.66	8	12	14	20	13	37.5	930.31	11.7	0.007	0.028	04051100CS0
4	12.56637	1507.96	120	39	39	35	3	62.83	125.66	12	12	10	15	9	37.5	1432.96	7.7	0.007	0.028	04051150C10
4	12.56637	1507.96	120	39	39	35	3	62.83	125.66	12	12	14	20	13	37.5	1432.96	11.7	0.007	0.028	04051150CS0
4	12.56637	2010.62	160	39	39	35	3	62.83	125.66	16	12	10	15	9	37.5	1935.62	7.7	0.008	0.032	04051200C10
4	12.56637	2010.62	160	39	39	35	3	62.83	125.66	16	12	14	20	13	37.5	1935.62	11.7	0.008	0.032	04051200CS0
5	15.70796	1005.31	64	49	39	34	3	62.83	125.66	8	12	14	20	13	30.1	945.11	11.7	0.007	0.028	05051100C10
6	18.84956	1017.88	54	59	49	43	3	63.62	127.23	8	16	18	26	17	31.4	955.08	15.7	0.007	0.028	06051100C10
8	25.13274	1005.31	40	79	79	71	3	62.83	125.66	8	25	22	33	21	26.6	952.11	19.7	0.008	0.031	08051100C10
10	31.41593	1005.31	32	99	99	89	3	62.83	125.66	8	32	33	48	32	125.66	753.99	19.7	0.008	0.031	10051100C10
12	37.69911	1017.88	27	120	120	108	3	63.62	127.23	8	40	39	58	38	127.23	763.42	19.7	0.01	0.033	12051100C10

(1) Teeth Pitch  $P_t = \text{Module} \times \pi$     (2)  $f_p = \text{Single Pitch Error}$     (3)  $F_p = \text{Total Pitch Error}$

\* For all models APEX also provides Rack without screw-holes. By ordering please change the 2nd last order-code position from "1" to "0". Please also refer to page 14.

Quality 6 / Carbon Steel  
 Tooth Thickness Tolerance : -22 ~ 0 μm  
 Straight Teeth  
 Teeth Induction Hardened and Ground  
 All Sides Ground

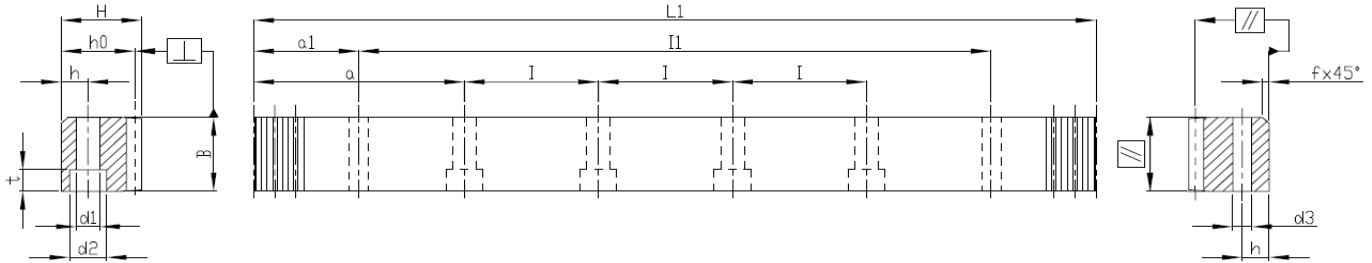

Mn	Pt <sup>(1)</sup>	LI	Teeth No.	B	H	ho	f	a	l	Hole No.	h	dl	d2	t	al	ll	d3	fp <sup>(2)</sup>	Fp <sup>(3)</sup>	Order Code*
1	3.14159	502.66	160	15	15	14	2	62.85	125.66	4	6	5	8	5	31.30	440.05	5.7	0.008	0.029	01061050C10
1	3.14159	1005.31	320	15	15	14	2	62.85	125.66	8	6	5	8	5	31.30	942.71	5.7	0.008	0.033	01061100C10
1	3.14159	1507.96	480	15	15	14	2	62.85	125.66	12	6	5	8	5	31.30	1445.36	5.7	0.008	0.033	01061150C10
2	6.28319	502.66	80	24	24	22	2	62.83	125.66	4	8	7	11	7	31.30	440.06	5.7	0.008	0.029	02061050C10
2	6.28319	1005.31	160	24	24	22	2	62.83	125.66	8	8	7	11	7	31.30	942.71	5.7	0.008	0.034	02061100C10
2	6.28319	2010.62	320	24	24	22	2	62.83	125.66	16	8	7	11	7	31.30	1948.02	5.7	0.009	0.038	02061200C10
3	9.42478	508.94	108	29	29	26	2	63.62	127.23	4	9	10	15	9	34.40	440.14	7.7	0.008	0.032	03061050C10
3	9.42478	1017.88	108	29	29	26	2	63.62	127.23	8	9	10	15	9	34.40	949.08	7.7	0.009	0.037	03061100C10
3	9.42478	2035.75	216	29	29	26	2	63.62	127.23	16	9	10	15	9	34.40	1966.952	7.7	0.010	0.042	03061200C10
4	12.56637	502.66	40	39	39	35	3	62.83	125.66	4	12	10	15	9	37.50	427.66	7.7	0.009	0.034	04061050C10
4	12.56637	502.66	40	39	39	35	3	62.83	125.66	4	12	14	20	13	37.50	427.66	11.7	0.009	0.034	04061050CS0
4	12.56637	1005.31	80	39	39	35	3	62.83	125.66	8	12	10	15	9	37.50	930.31	7.7	0.010	0.040	04061100C10
4	12.56637	1005.31	80	39	39	35	3	62.83	125.66	8	12	14	20	13	37.50	930.31	11.7	0.010	0.040	04061100CS0
4	12.56637	1507.96	120	39	39	35	3	62.83	125.66	12	12	14	20	13	37.50	1432.96	11.7	0.010	0.040	04061150CS0
4	12.56637	2010.62	160	39	39	35	3	62.83	125.66	16	12	10	15	9	37.50	1935.62	7.7	0.011	0.045	04061200C10
4	12.56637	2010.62	160	39	39	35	3	62.83	125.66	16	12	14	20	13	37.50	1935.62	11.7	0.011	0.045	04061200CS0
5	15.70796	502.66	32	49	39	34	3	62.83	125.66	4	12	14	20	13	30.10	442.46	11.7	0.009	0.034	05061050C10
5	15.70796	1005.31	64	49	39	34	3	62.83	125.66	8	12	14	20	13	30.10	945.11	11.7	0.010	0.040	05061100C10
5	15.70796	1507.96	96	49	39	34	3	62.83	125.66	12	12	14	20	13	30.10	1447.76	11.7	0.010	0.040	05061150C10
5	15.70796	2010.62	128	49	39	34	3	62.83	125.66	16	12	14	20	13	30.10	1950.42	11.7	0.011	0.045	05061200C10
6	18.84956	508.94	27	59	49	43	3	63.62	127.23	4	16	18	26	17	31.40	446.14	15.7	0.009	0.034	06061050C10
6	18.84956	1017.88	54	59	49	43	3	63.62	127.23	8	16	18	26	17	31.40	955.08	15.7	0.010	0.040	06061100C10
6	18.84956	1526.81	81	59	49	43	3	63.62	127.23	12	16	18	26	17	31.40	1464.01	15.7	0.010	0.040	06061150C10
6	18.84956	2035.75	108	59	49	43	3	63.62	127.23	16	16	18	26	17	31.40	1972.95	15.7	0.011	0.045	06061200C10
8	25.13274	502.66	20	79	79	71	3	62.83	125.66	4	25	22	33	21	26.60	449.46	19.7	0.011	0.037	08061050C10
8	25.13274	1005.31	40	79	79	71	3	62.83	125.66	8	25	22	33	21	26.60	952.11	19.7	0.011	0.043	08061100C10
8	25.13274	2010.62	80	79	79	71	3	62.83	125.66	16	25	22	33	21	26.60	1957.42	19.7	0.012	0.048	08061200C10
10	31.41593	1005.31	32	99	99	89	3	62.83	125.66	8	32	33	48	32	125.66	753.99	19.7	0.011	0.043	10061100C10
12	37.69911	1017.88	27	120	120	108	3	63.62	127.23	8	40	39	58	38	127.23	763.42	19.7	0.013	0.046	12061100C10

(1) Teeth Pitch Pt = Module x π    (2) fp = Single Pitch Error    (3) Fp = Total Pitch Error

\* For all models APEX also provides Rack without screw-holes. By ordering please change the 2nd last order-code position from "I" to "O". Please also refer to page 14.

# Rack with Straight Teeth

Quality 6M / Carbon Steel  
 Tooth Thickness Tolerance : -22 ~ 0  $\mu\text{m}$   
 Straight Teeth  
 Teeth Induction Hardened and Ground  
 All Sides Milled

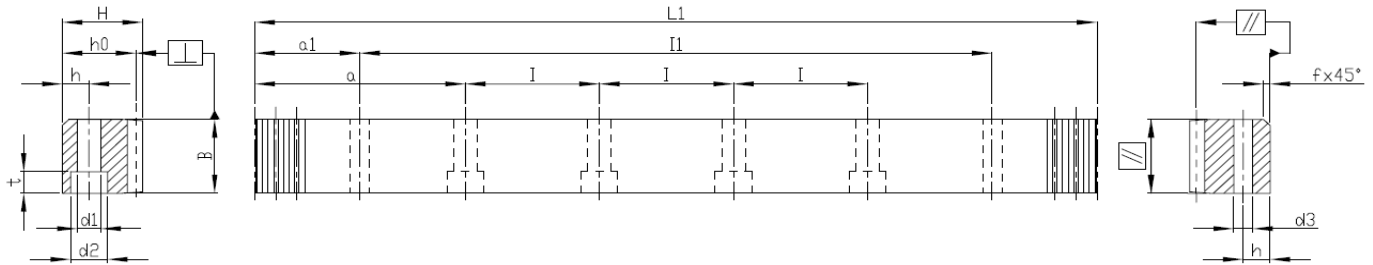

Mn	Pt <sup>(1)</sup>	L1	Teeth No.	B	H	h <sub>0</sub>	f	a	l	Hole No.	h	d1	d2	t	a1	l1	d3	f <sub>p</sub> <sup>(2)</sup>	F <sub>p</sub> <sup>(3)</sup>	Order Code *
2	6.28319	502.66	80	24	24	22	2	62.83	125.66	4	8	7	11	7	31.3	440.06	5.7	0.008	0.029	026M11050C10
2	6.28319	1005.31	160	24	24	22	2	62.83	125.66	8	8	7	11	7	31.3	942.71	5.7	0.008	0.034	026M11100C10
3	9.42478	508.94	54	29	29	26	2	63.62	127.23	4	9	10	15	9	34.4	440.14	7.7	0.008	0.032	036M11050C10
3	9.42478	1017.88	108	29	29	26	2	63.62	127.23	8	9	10	15	9	34.4	949.08	7.7	0.009	0.037	036M11100C10
4	12.56637	502.66	40	39	39	35	3	62.83	125.66	4	12	10	15	9	37.5	427.66	7.7	0.009	0.034	046M11050C10
4	12.56637	502.66	40	39	39	35	3	62.83	125.66	4	12	14	20	13	37.5	427.66	11.7	0.009	0.034	046M11050CS0
4	12.56637	1005.31	80	39	39	35	3	62.83	125.66	8	12	10	15	9	37.5	930.31	7.7	0.01	0.04	046M11100C10
4	12.56637	1005.31	80	39	39	35	3	62.83	125.66	8	12	14	20	13	37.5	930.31	11.7	0.01	0.04	046M11100CS0
5	15.70796	502.66	32	49	39	34	3	62.83	125.66	4	12	14	20	13	30.1	442.46	11.7	0.009	0.034	056M11050C10
5	15.70796	1005.31	64	49	39	34	3	62.83	125.66	8	12	14	20	13	30.1	945.11	11.7	0.01	0.04	056M11100C10
6	18.84956	508.94	27	59	49	43	3	63.62	127.23	4	16	18	26	17	31.4	446.14	15.7	0.009	0.034	066M11050C10
6	18.84956	1017.88	54	59	49	43	3	63.62	127.23	8	16	18	26	17	31.4	955.08	15.7	0.01	0.04	066M11100C10
8	25.13274	1005.31	40	79	79	71	3	62.83	125.66	8	25	22	33	21	26.6	952.11	19.7	0.011	0.043	086M11100C10

(1) Teeth Pitch Pt = Module  $\times \pi$     (2) f<sub>p</sub> = Single Pitch Error    (3) F<sub>p</sub> = Total Pitch Error

\* For all models APEX also provides Rack without screw-holes. By ordering please change the 2nd last order-code position from "1" to "0". Please also refer to page 14.

Quality 8H / Q&T Alloy Steel  
 Tooth Thickness Tolerance : -48 ~ 0  $\mu\text{m}$   
 Straight Teeth  
 Material Quenched and Tempered  
 Teeth Milled / All Sides Milled

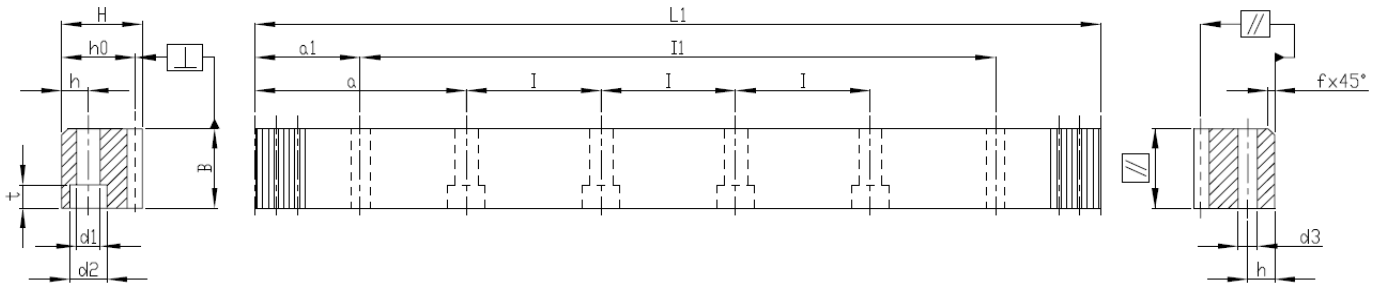

Mn	Pt <sup>(1)</sup>	LI	Teeth No.	B	H	ho	f	a	I	Hole No.	h	d1	d2	t	a1	II	d3	f <sub>p</sub> <sup>(2)</sup>	F <sub>p</sub> <sup>(3)</sup>	Order Code*
2	6.28319	1005.31	160	25	24	22	2	62.83	125.66	8	8	7	11	7	31.3	942.71	5.7	0.016	0.066	028H1100Q10
2	6.28319	2010.62	320	25	24	22	2	62.83	125.66	16	8	7	11	7	31.3	1948.02	5.7	0.018	0.074	028H1200Q10
3	9.42478	1017.88	108	30	29	26	2	63.62	127.23	8	9	10	15	9	34.4	949.08	7.7	0.018	0.072	038H1100Q10
3	9.42478	2035.75	216	30	29	26	2	63.62	127.23	16	9	10	15	9	34.4	1966.952	7.7	0.019	0.081	038H1200Q10
4	12.56637	1005.31	80	40	39	35	3	62.83	125.66	8	12	10	15	9	37.5	930.31	7.7	0.019	0.078	048H1100Q10
4	12.56637	2010.62	160	40	39	35	3	62.83	125.66	16	12	10	15	9	37.5	1935.62	7.7	0.021	0.088	048H1200Q10

(1) Teeth Pitch Pt = Module  $\times \pi$     (2) f<sub>p</sub> = Single Pitch Error    (3) F<sub>p</sub> = Total Pitch Error

\* For all models APEX also provides Rack without screw-holes. By ordering please change the 2nd last order-code position from "1" to "0". Please also refer to page 14.

Especially for the application without back-support.

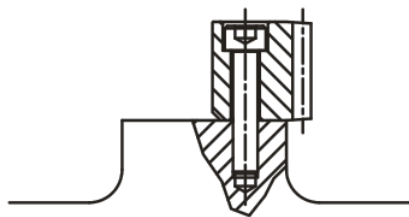

Without alignment / back-support

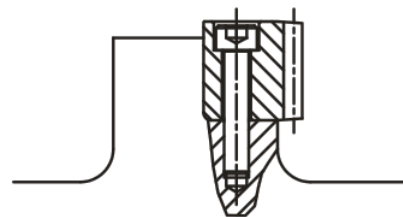

With alignment / back-support

# Rack with Straight Teeth

Quality 8 / Carbon Steel  
 Tooth Thickness Tolerance : -48 ~ 0  $\mu\text{m}$   
 Straight Teeth  
 Normalized, Teeth Milled  
 All Sides Milled

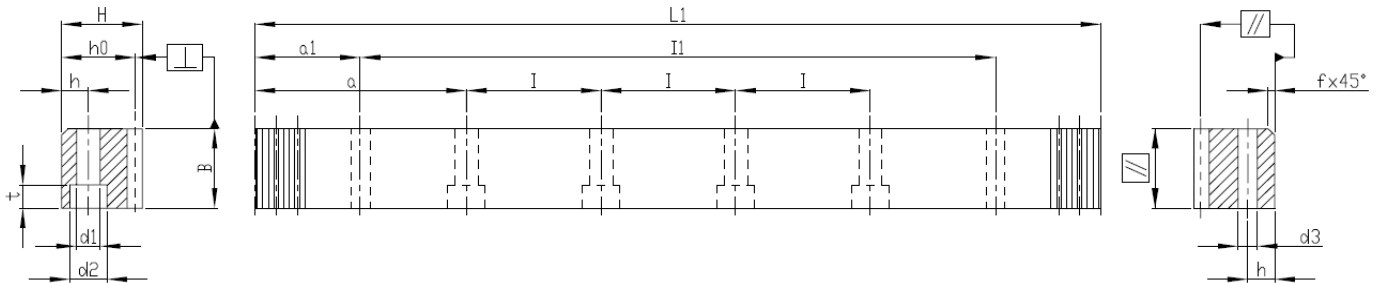

Mn	Pt <sup>(1)</sup>	L1	Teeth No.	B	H	h <sub>0</sub>	f	a	l	Hole No.	h	d1	d2	t	a1	l1	d3	f <sub>p</sub> <sup>(2)</sup>	F <sub>p</sub> <sup>(3)</sup>	Order Code *
1	3.14159	999.03	318	15	15	14.0	2	62.44	124.88	8	6	5	8	5	31.30	936.43	5.7	0.016	0.065	01081100C10
1	3.14159	1998.05	636	15	15	14.0	2	62.44	124.88	16	6	5	8	5	31.30	1935.45	5.7	0.018	0.074	01081200C10
1.5	4.71239	999.03	212	17	17	15.5	2	62.44	124.88	8	6	6	10	6	31.30	936.43	5.7	0.016	0.066	1J081100C10
1.5	4.71239	1998.05	424	17	17	15.5	2	62.44	124.88	16	6	6	10	6	31.30	1935.45	5.7	0.018	0.074	1J081200C10
2	6.28319	1005.31	160	26	24	22.0	2	62.83	125.66	8	8	7	11	7	31.30	942.71	5.7	0.016	0.066	02081100C10
2	6.28319	2010.62	320	26	24	22.0	2	62.83	125.66	16	8	7	11	7	31.30	1948.02	5.7	0.018	0.074	02081200C10
3	9.42478	1017.88	108	31	29	26.0	2	63.62	127.23	8	9	10	15	9	34.40	949.08	7.7	0.018	0.072	03081100C10
3	9.42478	2035.75	216	31	29	26.0	2	63.62	127.23	16	9	10	15	9	34.40	1966.95	7.7	0.019	0.081	03081200C10
4	12.56637	1005.31	80	41	39	35.0	3	62.83	125.66	8	12	10	15	9	37.50	930.31	7.7	0.019	0.078	04081100C10
4	12.56637	1005.31	80	41	39	35.0	3	62.83	125.66	8	12	14	20	13	37.50	930.31	11.7	0.019	0.078	04081100CS0
4	12.56637	2010.62	160	41	39	35.0	3	62.83	125.66	16	12	10	15	9	37.50	1935.62	7.7	0.021	0.088	04081200C10
4	12.56637	2010.62	160	41	39	35.0	3	62.83	125.66	16	12	14	20	13	37.50	1935.62	11.7	0.021	0.088	04081200CS0
5	15.70796	1005.31	64	50	39	34.0	3	62.83	125.66	8	12	14	20	13	30.10	945.11	11.7	0.019	0.078	05081100C10
5	15.70796	2010.62	128	50	39	34.0	3	62.83	125.66	16	12	14	20	13	30.10	1950.42	11.7	0.021	0.088	05081200C10
6	18.84956	1017.88	54	60	49	43.0	3	63.62	127.23	8	16	18	26	17	31.40	955.08	15.7	0.019	0.078	06081100C10
6	18.84956	2035.75	108	60	49	43.0	3	63.62	127.23	16	16	18	26	17	31.40	1972.95	15.7	0.021	0.088	06081200C10
8	25.13274	1005.31	40	81	79	71.0	3	62.83	125.66	8	25	22	33	21	26.60	952.11	19.7	0.022	0.084	08081100C10
8	25.13274	2010.62	80	81	79	71.0	3	62.83	125.66	16	25	22	33	21	26.60	1957.42	19.7	0.024	0.095	08081200C10
10	31.41593	1005.31	32	100	99	89.0	3	62.83	125.66	8	32	33	48	32	125.66	753.99	19.7	0.022	0.084	10081100C10
12	37.69911	1017.88	27	120	120	108.0	3	63.62	127.23	8	40	39	58	38	127.23	763.42	19.7	0.026	0.090	12081100C10

(1) Teeth Pitch Pt = Module  $\times \pi$     (2) f<sub>p</sub> = Single Pitch Error    (3) F<sub>p</sub> = Total Pitch Error

\* For all models APEX also provides Rack without screw-holes. By ordering please change the 2nd last order-code position from "1" to "0". Please also refer to page 14.



Quality 9 / Stainless Steel  
Tooth Thickness Tolerance : -63 ~ 0 μm  
Straight Teeth  
Solution, Teeth Milled  
All Sides Milled

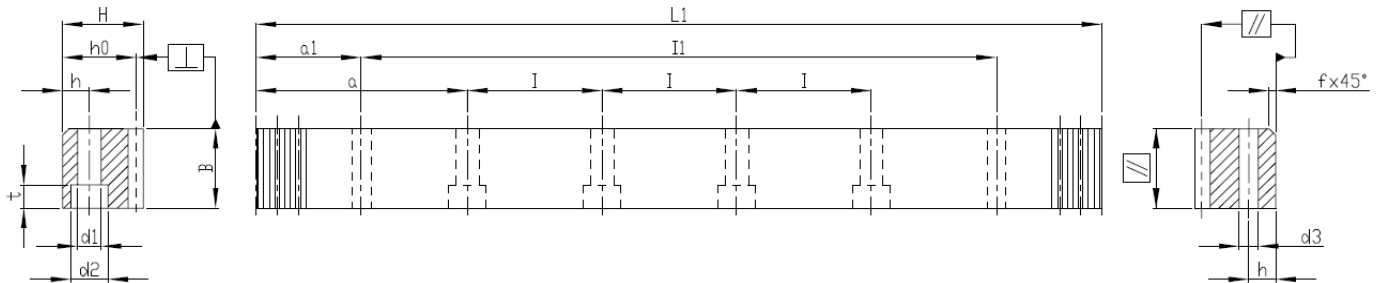

Mn	Pt <sup>(1)</sup>	L1	Teeth No.	B	H	ho	f	a	l	Hole No.	h	d1	d2	t	a1	l1	d3	f <sub>p</sub> <sup>(2)</sup>	F <sub>p</sub> <sup>(3)</sup>	Order Code*
1	3.14159	502.66	160	15	15	14.00	2	62.85	125.66	4	6.0	5	8	5	31.3	440.06	5.7	0.021	0.080	01091050S10
1	3.14159	1005.31	320	15	15	14.00	2	62.85	125.66	8	6.0	5	8	5	31.3	942.71	5.7	0.023	0.092	01091100S10
1.5	4.71239	508.94	108	17	17	15.50	2	63.62	127.23	4	6.0	6	10	6	34.4	440.14	5.7	0.021	0.080	1J091050S10
1.5	4.71239	1017.88	216	17	17	15.50	2	63.62	127.23	8	6.0	6	10	6	34.4	949.08	5.7	0.023	0.092	1J091100S10
1.75	5.49779	500.30	91	20	20	18.25	2	62.55	125.07	4	8.0	7	11	7	31.3	437.70	5.7	0.021	0.080	1P091050S10
1.75	5.49779	1000.60	182	20	20	18.25	2	62.55	125.07	8	8.0	7	11	7	31.3	938.00	5.7	0.023	0.092	1P091100S10
2	6.28319	502.66	80	26	24	22.00	2	62.83	125.66	4	8.0	7	11	7	31.3	440.06	5.7	0.021	0.080	02091050S10
2	6.28319	1005.31	160	26	24	22.00	2	62.83	125.66	8	8.0	7	11	7	31.3	942.71	5.7	0.023	0.092	02091100S10
3	9.42478	508.94	54	31	29	26.00	2	63.62	127.23	4	9.0	10	15	9	34.4	440.14	7.7	0.023	0.088	03091050S10
3	9.42478	1017.88	108	31	29	26.00	2	63.62	127.23	8	9.0	10	15	9	34.4	949.08	7.7	0.025	0.101	03091100S10
3	9.42478	1526.81	162	31	29	26.00	2	63.62	127.23	12	9.0	10	15	9	34.4	1458.01	7.7	0.025	0.101	03091150S10
3	9.42478	2035.75	216	31	29	26.00	2	63.62	127.23	16	9.0	10	15	9	34.4	1966.95	7.7	0.027	0.114	03091200S10
3.183	10.00000	1000.00	100	30	30	26.82	2	62.50	125.00	8	11.5	10	15	9	35.0	930.00	7.7	0.025	0.101	3B091100S10
3.183	10.00000	1500.00	150	30	30	26.82	2	62.50	125.00	12	11.5	10	15	9	35.0	1430.00	7.7	0.025	0.101	3B091150S10
3.183	10.00000	2000.00	200	30	30	26.82	2	62.50	125.00	16	11.5	10	15	9	35.0	1930.00	7.7	0.027	0.114	3B091200S10
4	12.56637	502.66	40	41	39	35.00	3	62.83	125.66	4	12.0	10	15	9	37.5	427.66	7.7	0.025	0.095	04091050S10
4	12.56637	1005.31	80	41	39	35.00	3	62.83	125.66	8	12.0	10	15	9	37.5	930.31	7.7	0.027	0.109	04091100S10
4	12.56637	1507.96	120	41	39	35.00	3	62.83	125.66	12	12.0	10	15	9	37.5	1432.96	7.7	0.027	0.109	04091150S10
4	12.56637	2010.62	160	41	39	35.00	3	62.83	125.66	16	12.0	10	15	9	37.5	1935.62	7.7	0.029	0.123	04091200S10
4.5	14.13717	1003.74	71	50	50	45.50	3	62.72	125.47	8	15.0	14	20	13	31.4	940.94	11.7	0.027	0.109	4J091100S10
4.5	14.13717	2007.48	142	50	50	45.50	3	62.72	125.47	16	15.0	14	20	13	31.4	1944.68	11.7	0.029	0.123	4J091200S10
5	15.70796	502.66	32	50	39	34.00	3	62.83	125.66	4	12.0	14	20	13	30.1	442.46	11.7	0.025	0.095	05091050S10
5	15.70796	1005.31	64	50	39	34.00	3	62.83	125.66	8	12.0	14	20	13	30.1	945.11	11.7	0.027	0.109	05091100S10
5	15.70796	1507.96	96	50	39	34.00	3	62.83	125.66	12	12.0	14	20	13	30.1	1447.76	11.7	0.027	0.109	05091150S10
5	15.70796	2010.62	128	50	39	34.00	3	62.83	125.66	16	12.0	14	20	13	30.1	1950.42	11.7	0.029	0.123	05091200S10
6	18.84956	508.94	27	60	49	43.00	3	63.62	127.23	4	16.0	18	26	17	31.4	446.14	15.7	0.025	0.095	06091050S10
6	18.84956	1017.88	54	60	49	43.00	3	63.62	127.23	8	16.0	18	26	17	31.4	955.08	15.7	0.027	0.109	06091100S10
6	18.84956	2035.75	108	60	49	43.00	3	63.62	127.23	16	16.0	18	26	17	31.4	1972.95	15.7	0.029	0.123	06091200S10

(1) Teeth Pitch Pt = Module × π    (2) f<sub>p</sub> = Single Pitch Error    (3) F<sub>p</sub> = Total Pitch Error

\* For all models APEX also provides Rack without screw-holes. By ordering please change the 2nd last order-code position from "1" to "0". Please also refer to page 14.

# Rack with Straight Teeth

Quality 10 / Carbon Steel  
 Tooth Thickness Tolerance : -90 ~ 0  $\mu\text{m}$   
 Straight Teeth  
 Teeth Induction Hardened  
 All Sides Milled

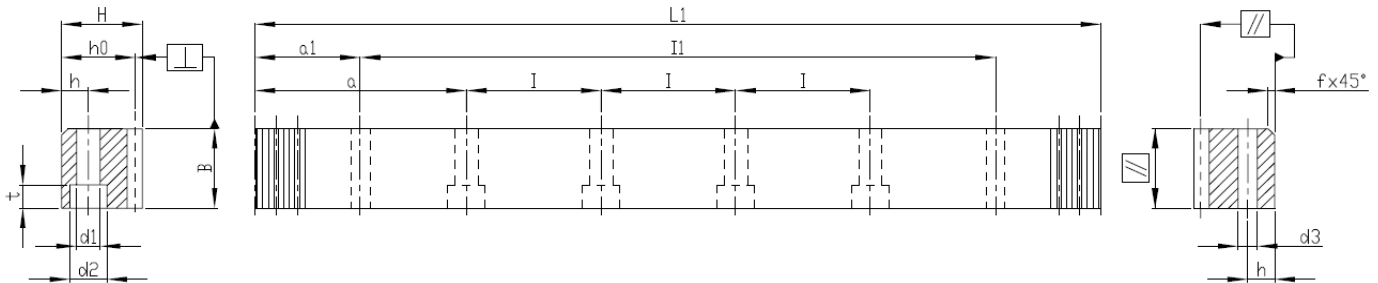

Mn	Pt <sup>(1)</sup>	L1	Teeth No.	B	H	ho	f	a	I	Hole No.	h	d1	d2	t	a1	I1	d3	f <sub>p</sub> <sup>(2)</sup>	F <sub>p</sub> <sup>(3)</sup>	Order Code *
1	3.14159	999.03	318	15	15	14.0	2	62.44	124.88	8	6	5	8	5	31.30	936.43	5.7	0.037	0.146	01101100C10
1	3.14159	1998.05	636	15	15	14.0	2	62.44	124.88	16	6	5	8	5	31.30	1935.50	5.7	0.037	0.146	01101200C10
1.5	4.71239	999.03	212	17	17	15.5	2	62.44	124.88	8	6	6	10	6	31.30	936.43	5.7	0.037	0.146	1J101100C10
1.5	4.71239	1998.05	424	17	17	15.5	2	62.44	124.88	16	6	6	10	6	31.30	1935.45	5.7	0.041	0.165	1J101200C10
2	6.28319	1005.31	160	26	24	22.0	2	62.83	125.66	8	8	7	11	7	31.30	942.71	5.7	0.037	0.148	02101100C10
2	6.28319	2010.62	320	26	24	22.0	2	62.83	125.66	16	8	7	11	7	31.30	1948.02	5.7	0.041	0.167	02101200C10
3	9.42478	1017.88	108	31	29	26.0	2	63.62	127.23	8	9	10	15	9	34.40	949.08	7.7	0.039	0.162	03101100C10
3	9.42478	2035.75	216	31	29	26.0	2	63.62	127.23	16	9	10	15	9	34.40	1966.95	7.7	0.043	0.182	03101200C10
4	12.56637	1005.31	80	41	39	35.0	3	62.83	125.66	8	12	10	15	9	37.50	930.31	7.7	0.043	0.175	04101100C10
4	12.56637	1005.31	80	41	39	35.0	3	62.83	125.66	8	12	14	20	13	37.50	930.31	11.7	0.043	0.175	04101100CS0
4	12.56637	2010.62	160	41	39	35.0	3	62.83	125.66	16	12	10	15	9	37.50	1935.62	7.7	0.047	0.197	04101200C10
4	12.56637	2010.62	160	41	39	35.0	3	62.83	125.66	16	12	14	20	13	37.50	1935.62	11.7	0.047	0.197	04101200CS0
5	15.70796	1005.31	64	50	39	34.0	3	62.83	125.66	8	12	14	20	13	30.10	945.11	11.7	0.043	0.175	05101100C10
5	15.70796	2010.62	128	50	39	34.0	3	62.83	125.66	16	12	14	20	13	30.10	1950.42	11.7	0.047	0.197	05101200C10
6	18.84956	1017.88	54	60	49	43.0	3	63.62	127.23	8	16	18	26	17	31.40	955.08	15.7	0.043	0.175	06101100C10
6	18.84956	2035.75	108	60	49	43.0	3	63.62	127.23	16	16	18	26	17	31.40	1972.95	15.7	0.047	0.197	06101200C10
8	25.13274	1005.31	40	81	79	71.0	3	62.83	125.66	8	25	22	33	21	26.60	952.11	19.7	0.049	0.188	08101100C10
8	25.13274	2010.62	80	81	79	71.0	3	62.83	125.66	16	25	22	33	21	26.60	1957.42	19.7	0.053	0.212	08101200C10
10	31.41593	1005.31	32	100	99	89.0	3	62.83	125.66	8	32	33	48	32	125.66	753.99	19.7	0.049	0.188	10101100C10
12	37.69911	1017.88	27	120	120	108.0	3	63.62	127.23	8	40	39	58	38	127.23	763.42	19.7	0.059	0.202	12101100C10

(1) Teeth Pitch Pt = Module  $\times \pi$     (2) f<sub>p</sub> = Single Pitch Error    (3) F<sub>p</sub> = Total Pitch Error

\* For all models APEX also provides Rack without screw-holes. By ordering please change the 2nd last order-code position from "1" to "0". Please also refer to page 14.

# Rack with Straight Teeth

( with Linear-Guide Interface, 90° Type )

Quality 6 / Carbon Steel  
 Tooth Thickness Tolerance : -22 ~ 0 μm  
 Straight Teeth  
 Teeth Induction Hardened and Ground  
 All Sides Ground

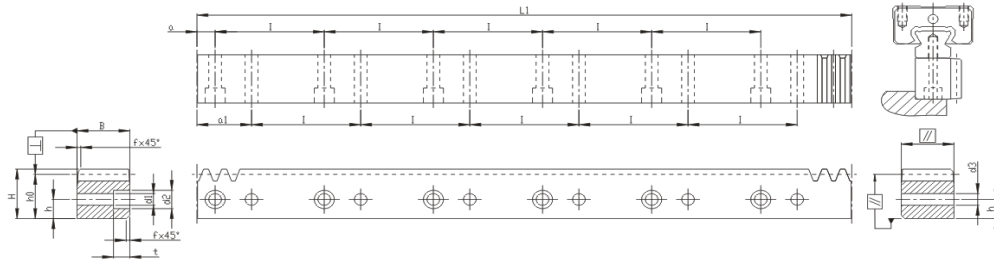

Mn	p <sup>(1)</sup>	LI	Teeth No.	B	H	ho	f	a	l	Hole No.	h	dl	d2	t	al	d3	fp <sup>(2)</sup>	Fp <sup>(3)</sup>	Order Code
1.591	5	960	192	19	19.50	17.91	1	10	60	16	7.5	4.5	7.5	5.3	30	4.5	0.008	0.034	1K061100C10A1
1.591	5	960	192	24	24.50	22.91	1	10	60	16	10.0	6	9.5	8.5	30	6	0.008	0.034	1K061100CS0A1
3.183	10	960	96	29	29.75	26.57	2	10	60	16	11.5	7	11.0	9.0	30	7	0.009	0.037	3B061100C10A1
4.244	13.33	960	72	39	39.75	35.51	2	20	80	12	14.0	10	15.0	9.0	40	10	0.010	0.040	4D061100C10A1

Quality 8 / Carbon Steel  
 Tooth Thickness Tolerance : -48 ~ 0 μm  
 Straight Teeth  
 Teeth Milled, All Side Milled

Mn	p <sup>(1)</sup>	LI	Teeth No.	B	H	ho	f	a	l	Hole No.	h	dl	d2	t	al	d3	fp <sup>(2)</sup>	Fp <sup>(3)</sup>	Order Code
1.591	5	1920	384	20	19.50	17.91	1	10	60	32	7.5	4.5	7.5	5.3	30	4.5	0.018	0.074	1K081200C10A1
1.591	5	1920	384	25	24.50	22.91	1	10	60	32	10.0	6.0	9.5	8.5	30	6.0	0.018	0.074	1K081200CS0A1
3.183	10	1920	192	30	29.75	26.57	2	10	60	32	11.5	7.0	11.0	9.0	30	7.0	0.019	0.081	3B081200C10A1
4.244	13.33	1920	144	40	39.75	35.51	2	20	80	24	14.0	10.0	15.0	9.0	40	10.0	0.021	0.088	4D081200C10A1

(1) Teeth Pitch Pt = Module × π    (2) fp = Single Pitch Error    (3) Fp = Total Pitch Error

# Rack with Straight Teeth

( with Linear-Guide Interface, 180° Type )

Quality 6 / Carbon Steel  
 Tooth Thickness Tolerance : -22 ~ 0 μm  
 Straight Teeth  
 Teeth Induction Hardened and Ground  
 All Sides Ground

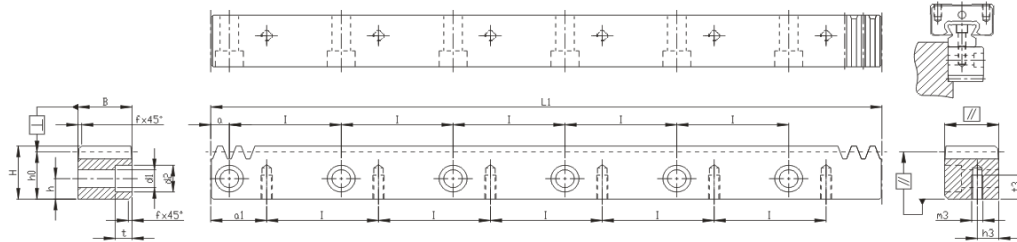

Mn	p <sup>(1)</sup>	LI	Teeth No.	B	H	ho	f	a	l	Hole No.	h	d1	d2	t	a1	m3	h3	t3	f <sub>p</sub> <sup>(2)</sup>	F <sub>p</sub> <sup>(3)</sup>	Order Code
1.591	5.00	960	192	19	19.50	17.91	1	10	60	16	7.5	6	9.5	6	30	M4	7.5	8.0	0.008	0.034	1K061100C10A2
1.591	5.00	960	192	24	24.50	22.91	1	10	60	16	10.0	7	11	7	30	M5	10.0	11.0	0.008	0.034	1K061100CS0A2
3.183	10.00	960	96	29	29.75	26.57	2	10	60	16	11.5	10	15	9	30	M6	11.5	13.5	0.009	0.037	3B061100C10A2
4.244	13.33	960	72	39	39.75	35.51	2	20	80	12	14.0	12	18	12	40	M8	14.0	16.0	0.010	0.040	4D061100C10A2

Quality 8 / Carbon Steel  
 Tooth Thickness Tolerance : -48 ~ 0 μm  
 Straight Teeth  
 Teeth Milled, All Side Milled

Mn	p <sup>(1)</sup>	LI	Teeth No.	B	H	ho	f	a	l	Hole No.	h	d1	d2	t	a1	m3	h3	t3	f <sub>p</sub> <sup>(2)</sup>	F <sub>p</sub> <sup>(3)</sup>	Order Code
1.591	5.00	1920	384	20	19.5	17.91	1	10	60	32	7.5	6	9.5	6	30	M4	7.5	8.0	0.018	0.074	1K081200C10A2
1.591	5.00	1920	384	25	24.5	22.91	1	10	60	32	10.0	7	11.0	7	30	M5	10.0	11.0	0.018	0.074	1K081200CS0A2
3.183	10.00	1920	192	30	29.75	26.57	2	10	60	32	11.5	10	15.0	9	30	M6	11.5	13.5	0.019	0.081	3B081200C10A2
4.244	13.33	1920	144	40	39.75	35.51	2	20	80	24	14.0	12	18.0	12	40	M8	14.0	16.0	0.021	0.088	4D081200C10A2

(1) Teeth Pitch Pt = Module × π    (2) fp = Single Pitch Error    (3) Fp = Total Pitch Error

# Pinion with Straight Teeth

( Interface : Curvic Plate / EN ISO 9409-I-A )

Quality DIN 4 / Alloy Steel

Tooth Thickness Tolerance : e24

Straight Teeth

Case-Hardened and Teeth Ground

Bolt Circle Ø50

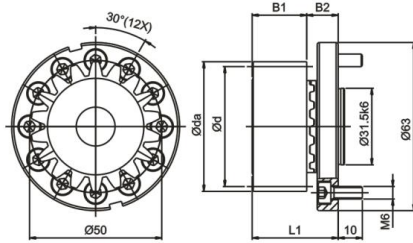

Fig. A

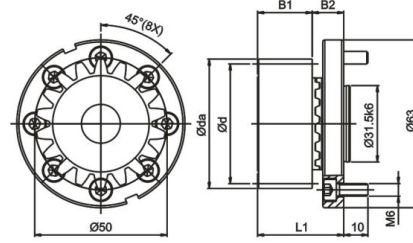

Fig. B

Mn	z <sup>(1)</sup>	x <sup>(2)</sup>	da <sup>(3)</sup>	d <sup>(4)</sup>	dw <sup>(5)</sup>	B1	B2	L1	L <sup>(6)</sup>	Fig	Order Code	
											Set	Pinion only
2	21	0.5	48	42	44	26	15	41	131.947	A	A02121A050	A02121
										B	A02121B050	

Bolt Circle Ø63

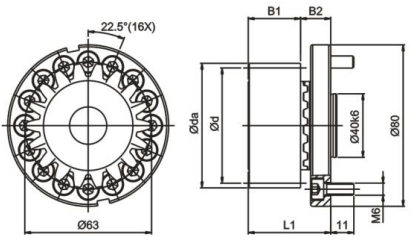

Fig. A

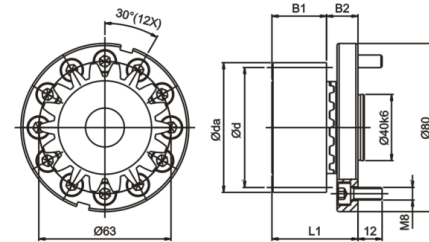

Fig. C

Mn	z <sup>(1)</sup>	x <sup>(2)</sup>	da <sup>(3)</sup>	d <sup>(4)</sup>	dw <sup>(5)</sup>	B1	B2	L1	L <sup>(6)</sup>	Fig	Order Code		
											Set	Pinion only	
2	21	0.5	48	42	44	26	15	41	131.947	A	A02121A063	A02121	
							19.5	45.5			C		A02121C063

Bolt Circle Ø80

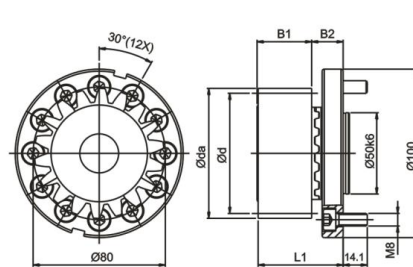

Fig. A

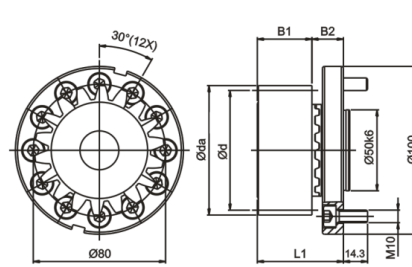

Fig. C

Mn	z <sup>(1)</sup>	x <sup>(2)</sup>	da <sup>(3)</sup>	d <sup>(4)</sup>	dw <sup>(5)</sup>	B1	B2	L1	L <sup>(6)</sup>	Fig	Order Code	
											Set	Pinion only
3	19	0.1667	64	57	58	31	21.5	52.5	179.071	A	A03119A080	A03119
										C	A03119C080	

(1) Number of teeth (2) Profile modification factor (3) Diameter of addendum circle (4) Pitch circle diameter  
 (5) Working pitch circle diameter (6) Pitch circle length  $L = \pi \times d$

# Pinion with Straight Teeth

( Interface : Curvic Plate / EN ISO 9409-I-A )

Quality DIN 4 / Alloy Steel  
 Tooth Thickness Tolerance : e24  
 Straight Teeth  
 Case-Hardened and Teeth Ground

## Bolt Circle Ø125

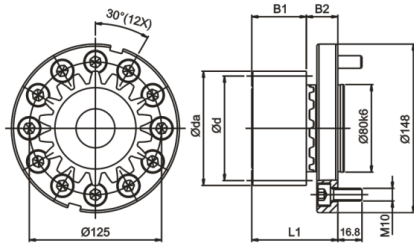

Fig. A

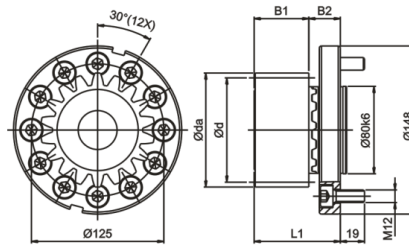

Fig. C

Mn	z <sup>(1)</sup>	x <sup>(2)</sup>	da <sup>(3)</sup>	d <sup>(4)</sup>	dw <sup>(5)</sup>	B1	B2	L1	L <sup>(6)</sup>	Fig	Order Code	
											Set	Pinion only
4	19	0.6875	89.5	76	81.5	41	29	70	238.761	A	A04119A125	A04119
										C	A04119C125	

## Bolt Circle Ø140 / Ø145

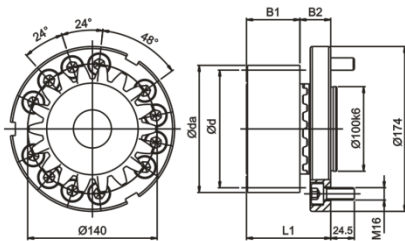

Fig. A

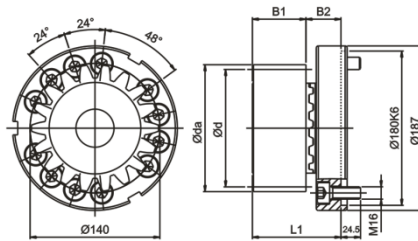

Fig. B

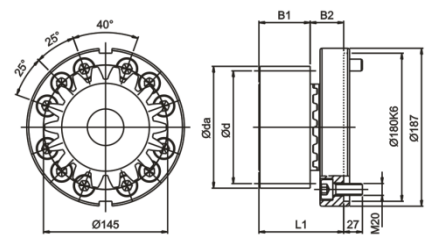

Fig. C

Mn	z <sup>(1)</sup>	x <sup>(2)</sup>	da <sup>(3)</sup>	d <sup>(4)</sup>	dw <sup>(5)</sup>	B1	B2	L1	L <sup>(6)</sup>	Fig	Order Code	
											Set	Pinion only
5	19	0.3	108	95	98	51	38	89	298.451	A	A05119A140	A05119
										B	A05119B140	
										C	A05119C145	

Quality DIN 4 / Alloy Steel  
 Tooth Thickness Tolerance : e24  
 Straight Teeth  
 Case-Hardened and Teeth Ground

Bolt Circle Ø160 / Ø166

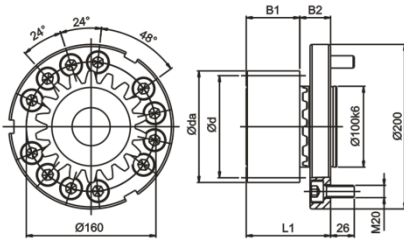

Fig. A

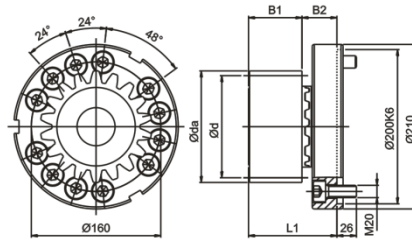

Fig. B

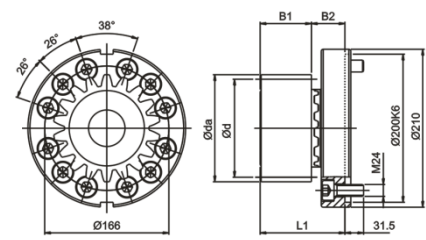
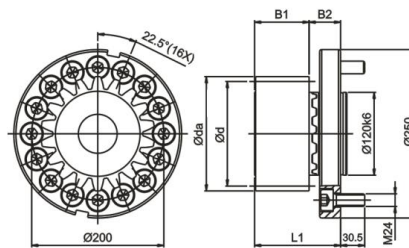

Fig. C

Mn	z <sup>(1)</sup>	x <sup>(2)</sup>	da <sup>(3)</sup>	d <sup>(4)</sup>	dw <sup>(5)</sup>	B1	B2	L1	L <sup>(6)</sup>	Fig	Order Code	
											Set	Pinion only
6	19	0.25	129	114	117	61	49	110	358.142	A	A06119A160	A06119
										B	A06119B160	
										C	A06119C166	

Bolt Circle Ø200



Mn.	z <sup>(1)</sup>	x <sup>(2)</sup>	da <sup>(3)</sup>	d <sup>(4)</sup>	dw <sup>(5)</sup>	B1	B2	L1	L <sup>(6)</sup>	Order Code	
										Set	Pinion only
8	16	0.3125	149	128	133	81	50	131	402.124	A08116A200	A08116

(1) Number of teeth (2) Profile modification factor (3) Diameter of addendum circle (4) Pitch circle diameter  
 (5) Working pitch circle diameter (6) Pitch circle length  $L = \pi \times d$

# Pinion with Straight Teeth

( Interface : Curvic Plate / EN ISO 9409-I-A )

Quality DIN 4 / Alloy Steel  
 Tooth Thickness Tolerance : e24  
 Straight Teeth  
 Case-Hardened and Teeth Ground

Bolt Circle Ø250

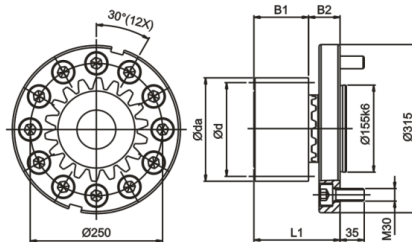

Mn.	z <sup>(1)</sup>	x <sup>(2)</sup>	da <sup>(3)</sup>	d <sup>(4)</sup>	dw <sup>(5)</sup>	B1	B2	L1	L <sup>(6)</sup>	Order Code	
										Set	Pinion only
10	15	0.45	179	150	159	101	62	163	471.239	A10115A250	A10115

(1) Number of teeth (2) Profile modification factor (3) Diameter of addendum circle (4) Pitch circle diameter  
 (5) Working pitch circle diameter (6) Pitch circle length  $L = \pi * d$

Pinion material carburized, the surface hardness reaches to 60 HRc after case hardening  
 Teeth surface ground in order to reduce noise and improve wear resistance  
 Accessories include hexagon socket head cap screws ( Strength 12.9 · DIN 912 )

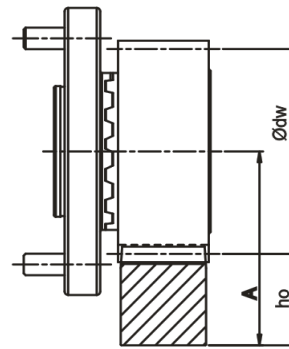
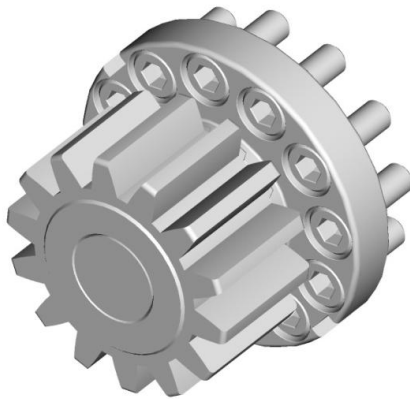

$$A = h_o + \frac{\phi dw}{2}$$

In Table 7, the maximum permissible torque of the Curvic Plate pinion and the rack is calculated on the basis of a speed of 1.5 m/s and providing good lubrication (using an automatic lubrication system or manually applied grease every day), the tooth root strength factor  $S_F \geq 1.4$ , tooth surface strength coefficient  $S_H \geq 1$ , the safety factor  $S_B \cong 1$ , and the required service life of 20,000 hours. By higher speed, the max. permissible torque reduced. The user needs to increase the safety factor for the application.

Backlash changes by different center height. Please contact APEX under [WWW.APEXDYNA.COM](http://WWW.APEXDYNA.COM).



Table 7. The max. permitted torque and feed-force of pinion with Curvic Plate

Pinion \ Rack			Quality	Q4	Q5H	Q5	Q6	Q6M	Q8H	Q8	Q9	Q10	
			Material	Carbon Steel	Alloy Steel		Carbon Steel	Carbon Steel	Carbon Steel	Q&T Alloy Steel	Carbon Steel	Stainless Steel	Carbon Steel
			Heat Treatment	Induction Hardening	Case Hardening	Carburized Induction	Induction Hardening	Induction Hardening	Induction Hardening	Quenched Tempered	Normalizing	Solution	Induction Hardening
Mn	z <sup>(1)</sup>	dw <sup>(5)</sup>	Max. Torque * and Feed-Force										
2	21	44	F <sub>2T</sub> <sup>(8)</sup> (N)		7,857	7,857		6,429	6,429	1,905	1,190	714	4,048
			T <sub>2B</sub> <sup>(9)</sup> (Nm)		165	165		135	135	40	25	15	85
3	19	58	F <sub>2T</sub> <sup>(8)</sup> (N)		14,211	14,211		13,860	13,860	7,018	3,684	1,754	9,825
			T <sub>2B</sub> <sup>(9)</sup> (Nm)		405	405		395	395	200	105	50	280
	21	66	F <sub>2T</sub> <sup>(8)</sup> (N)		14,921	14,921		12,381	12,381	4,444	2,540	1,270	9,683
			T <sub>2B</sub> <sup>(9)</sup> (Nm)		470	470		390	390	140	80	40	305
4	19	81.5	F <sub>2T</sub> <sup>(8)</sup> (N)		27,105		26,974	26,711	26,711	13,289	7,500	3,026	20,921
			T <sub>2B</sub> <sup>(9)</sup> (Nm)		1,030		1,025	1,015	1,015	505	285	115	795
5	19	98	F <sub>2T</sub> <sup>(8)</sup> (N)	44,316	44,316		44,316	44,211	44,211		14,316	5,263	36,211
			T <sub>2B</sub> <sup>(9)</sup> (Nm)	2,105	2,105		2,105	2,100	2,100		680	250	1,720
6	19	117	F <sub>2T</sub> <sup>(8)</sup> (N)	63,333	63,333		63,246	63,246	63,246		22,982	9,474	54,123
			T <sub>2B</sub> <sup>(9)</sup> (Nm)	3,610	3,610		3,605	3,605	3,605		1,310	540	3,085
8	16	133	F <sub>2T</sub> <sup>(8)</sup> (N)	93,125	93,125		93,125	93,125	93,125		34,531		76,563
			T <sub>2B</sub> <sup>(9)</sup> (Nm)	5,960	5,960		5,960	5,960	5,960		2,210		4,900
10	15	159	F <sub>2T</sub> <sup>(8)</sup> (N)	144,000	144,000		144,000	144,000	144,000		54,000		131,467
			T <sub>2B</sub> <sup>(9)</sup> (Nm)	10,800	10,800		10,800	10,800	10,800		4,050		9,860

\* The Maximal Driving Torque is also to be understood as the Maximal Acceleration Torque T<sub>2B</sub>.

The Emergency Stop Torque T<sub>2NOT</sub> = 2 x T<sub>2B</sub>, under the condition limited 1000 times in the whole service period.

(1) Number of Teeth (5) Working Pitch Circle Diameter (in mm) (8) Maximum Feed-Force (9) Maximum Driving Torque

# Pinion with Straight Teeth

( Interface : Welded Plate / EN ISO 9409-I-A )

Quality DIN 4 / Alloy Steel  
 Tooth Thickness Tolerance : e24  
 Straight Teeth  
 Case-Hardened and Teeth Ground

Bolt Circle Ø 50

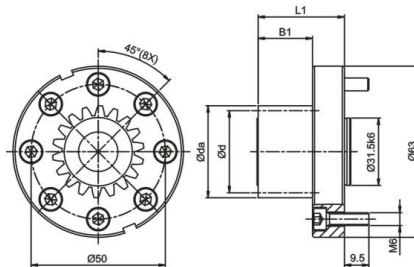

Mn	z <sup>(1)</sup>	x <sup>(2)</sup>	da <sup>(3)</sup>	d <sup>(4)</sup>	dw <sup>(5)</sup>	BI	LI	L <sup>(6)</sup>	Order Code
2	13	0.366	31.464	26	27.464	26	41	81.681	B02113A050
	17	-0.012	37.952	34	33.952	26	41	106.814	B02117A050

Bolt Circle Ø 63

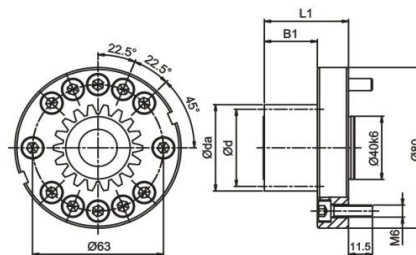

Mn	z <sup>(1)</sup>	x <sup>(2)</sup>	da <sup>(3)</sup>	d <sup>(4)</sup>	dw <sup>(5)</sup>	BI	LI	L <sup>(6)</sup>	Order Code
2	13	0.366	31.464	26	27.464	26	41	81.681	B02113A063
	17	-0.012	37.952	34	33.952	26	41	106.814	B02117A063
	24	0.202	52.808	48	48.808	26	41	150.796	B02124A063
3	13	0.366	47.196	39	41.196	32.5	47.5	122.522	B03113A063

(1) Number of teeth (2) Profile modification factor (3) Diameter of addendum circle (4) Pitch circle diameter  
 (5) Working pitch circle diameter (6) Pitch circle length  $L = \pi \times d$

Quality DIN 4 / Alloy Steel  
 Tooth Thickness Tolerance : e24  
 Straight Teeth  
 Case-Hardened and Teeth Ground

Bolt Circle Ø 80

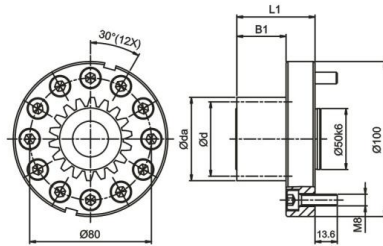

Mn	z <sup>(1)</sup>	x <sup>(2)</sup>	da <sup>(3)</sup>	d <sup>(4)</sup>	dw <sup>(5)</sup>	BI	LI	L <sup>(6)</sup>	Order Code
2	13	0.366	31.464	26	27.464	26	46	81.681	B02113A080
	24	0.202	52.808	48	48.808	26	46	150.796	B02124A080
3	13	0.366	47.196	39	41.196	32.5	52.5	122.522	B03113A080
	20	0.08	66.48	60	60.48	32.5	52.5	188.496	B03120A080
4	13	0.366	62.928	52	54.928	45	65	163.363	B04113A080

Bolt Circle Ø 125

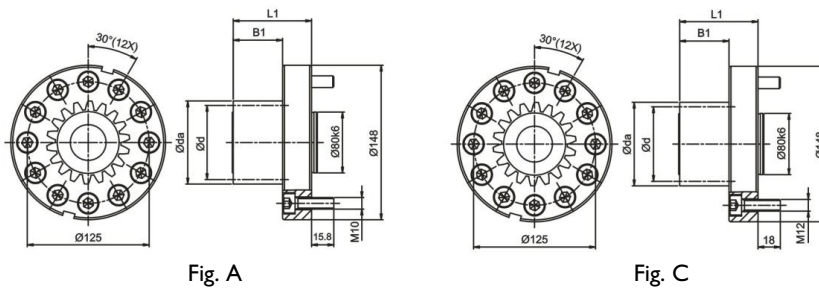

Fig. A

Fig. C

Mn	z <sup>(1)</sup>	x <sup>(2)</sup>	da <sup>(3)</sup>	d <sup>(4)</sup>	dw <sup>(5)</sup>	BI	LI	L <sup>(6)</sup>	Fig	Order Code
3	13	0.366	47.196	39	41.196	32.5	57.5	122.522	A	B03113A125
									C	B03113C125
	20	0.08	66.48	60	60.48	32.5	57.5	188.496	A	B03120A125
									C	B03120C125
	27	0.294	88.764	81	82.764	32.5	57.5	254.469	C	B03127C125
4	13	0.366	62.928	52	54.928	45	70	163.363	A	B04113A125
									C	B04113C125
	20	0.19	89.52	80	81.52	45	70	251.327	A	B04120A125
									C	B04120C125
	21	0.11	92.88	84	84.88	45	70	263.894	A	B04121A125
									C	B04121C125
24	0.202	105.616	96	97.616	45	70	301.593	A	B04124A125	
								C	B04124C125	
5	13	0.366	78.66	65	68.66	55	80	204.204	A	B05113A125
									C	B05113C125
	17	-0.012	94.88	85	84.88	55	80	267.035	C	B05117C125
19	0.049	105.49	95	95.49	55	80	298.451	A	B05119A125	
								C	B05119C125	
6	13	0.366	94.392	78	82.392	65	90	245.044	A	B06113A125
									C	B06113C125
	14	0.397	100.764	84	88.764	65	90	263.894	A	B06114A125
16	-0.042	107.496	96	95.496	65	90	301.593	A	B06116A125	

# Pinion with Straight Teeth

( Interface : Welded Plate / EN ISO 9409-1-A )

Quality DIN 4 / Alloy Steel

Tooth Thickness Tolerance : e24

Straight Teeth

Case-Hardened and Teeth Ground

Bolt Circle  $\varnothing 140$

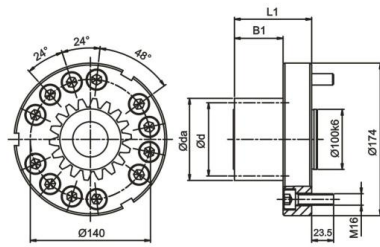

Fig. A

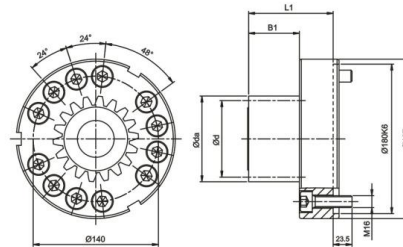

Fig. B

Mn	$z^{(1)}$	$x^{(2)}$	$d_a^{(3)}$	$d^{(4)}$	$d_w^{(5)}$	BI	LI	$L^{(6)}$	Fig	Order Code
4	13	0.366	62.928	52	54.928	45	79	163.363	A	B04113A140
									B	B04113B140
	20	0.19	89.52	80	81.52	45	79	251.327	A	B04120A140
									B	B04120B140
21	0.11	92.88	84	84.88	45	79	263.894	A	B04121A140	
								B	B04121B140	
5	15	0.227	87.27	75	77.27	55	89	235.619	A	B05115A140
									B	B05115B140
	20	0.08	110.8	100	100.8	55	89	314.159	A	B05120A140
									B	B05120B140
6	13	0.366	94.392	78	82.392	65	99	245.044	A	B06113A140
									B	B06113B140
	17	-0.012	113.856	102	101.856	65	99	320.442	A	B06117A140
									B	B06117B140

Quality DIN 4 / Alloy Steel  
 Tooth Thickness Tolerance : e24  
 Straight Teeth  
 Case-Hardened and Teeth Ground

Bolt Circle Ø160

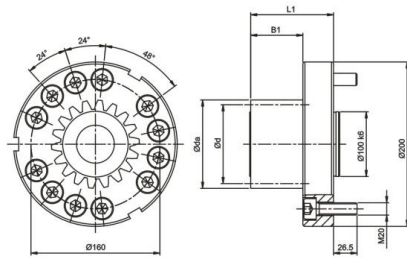

Fig. A

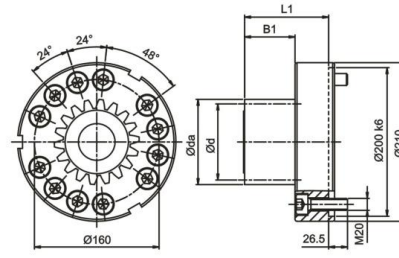
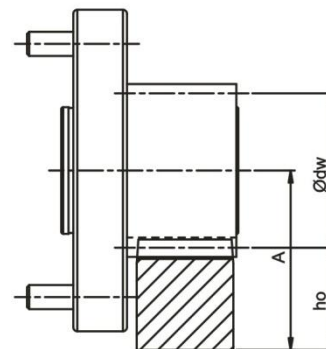
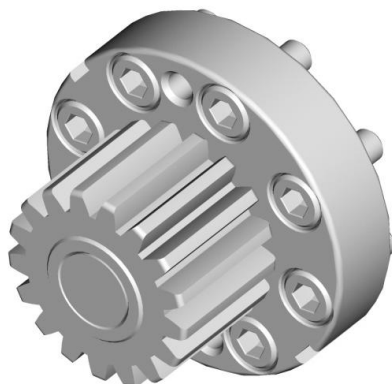

Fig. B

Mn	z <sup>(1)</sup>	x <sup>(2)</sup>	da <sup>(3)</sup>	d <sup>(4)</sup>	dw <sup>(5)</sup>	B1	L1	L <sup>(6)</sup>	Fig	Order Code
5	13	0.366	78.66	65	68.66	55	100	204.204	A	B05113A160
	20	0.08	110.8	100	100.8	55	100	314.159	B	B05113B160
6	13	0.366	94.392	78	82.392	65	110	245.044	A	B06113A160
									B	B06113B160
	17	-0.012	113.856	102	101.856	65	110	320.442	A	B06117A160
									B	B06117B160
8	13	0.366	126.588	114	114.588	65	110	358.142	A	B06119A160
									B	B06119B160
8	13	0.366	125.856	104	109.856	85	130	326.726	A	B08113A160
									B	B08113B160

(1) Number of teeth (2) Profile modification factor (3) Diameter of addendum circle (4) Pitch circle diameter  
 (5) Working pitch circle diameter (6) Pitch circle length  $L = \pi \times d$

Pinion material carburized, the surface hardness reached 60 HRC  
 Teeth surface ground in order to reduce noise and improve wear resistance  
 Accessories include hexagon socket head cap screws (Strength 12.9 · DIN 912)



$$A = h_o + \frac{\phi dw}{2}$$

In Table 8, the maximum permissible torque of the pinion Welded Plate and the rack is calculated on the basis of a speed of 1.5 m/s and providing good lubrication (using an automatic lubrication system or manually applied grease every day), the tooth root strength factor  $S_F \geq 1.4$ , tooth surface strength coefficient  $S_H \geq 1$ , the safety factor  $S_B \cong 1$ , and the required service life of 20,000 hours. By higher speed, the max. permissible torque reduced. The user needs to increase the safety factor for the application. Backlash changes by different center height. Please contact APEX under WWW.APEXDYNA.COM.

# Pinion with Straight Teeth

( Interface : Welded Plate / EN ISO 9409-I-A )

Table 8. The max. permitted torque and feed-force of pinion Welded Plate

Pinion \ Rack			Quality	Q4	Q5H	Q5		Q6	Q6M	Q8H	Q8	Q9	Q10
			Material	Carbon Steel	Alloy Steel		Carbon Steel	Carbon Steel	Carbon Steel	Q&T Alloy Steel	Carbon Steel	Stainless Steel	Carbon Steel
			Heat Treatment	Induction Hardening	Case Hardening	Carburized Induction	Induction Hardening	Induction Hardening	Induction Hardening	Quenched Tempered	Normalizing	Solution	Induction Hardening
Mn	z <sup>(1)</sup>	dw <sup>(5)</sup>	Max. Torque* and Feed-Force										
2	13	27.264	F <sub>2T</sub> <sup>(8)</sup> (N)		4,231	4,231		4,231	4,231	1,538	769	385	1,923
			T <sub>2B</sub> <sup>(9)</sup> (Nm)		55	55		55	55	20	10	5	25
	17	33.952	F <sub>2T</sub> <sup>(8)</sup> (N)		5,000	5,000		5,000	5,000	2,353	1,471	588	2,059
			T <sub>2B</sub> <sup>(9)</sup> (Nm)		85	85		85	85	40	25	10	35
	24	48.808	F <sub>2T</sub> <sup>(8)</sup> (N)		8,333	8,333		6,875	6,875	2,292	1,458	833	3,542
			T <sub>2B</sub> <sup>(9)</sup> (Nm)		200	200		165	165	55	35	20	85
3	13	41.196	F <sub>2T</sub> <sup>(8)</sup> (N)		8,462	8,462		8,462	8,462	3,333	2,051	1,025	4,615
			T <sub>2B</sub> <sup>(9)</sup> (Nm)		165	165		165	165	65	40	20	90
	20	60.48	F <sub>2T</sub> <sup>(8)</sup> (N)		14,833	14,833		13,333	13,333	4,500	2,333	1,333	10,000
			T <sub>2B</sub> <sup>(9)</sup> (Nm)		445	445		400	400	135	70	40	300
	27	82.764	F <sub>2T</sub> <sup>(8)</sup> (N)		15,679	15,679		13,086	13,086	7,654	4,074	1,728	9,630
			T <sub>2B</sub> <sup>(9)</sup> (Nm)		635	635		530	530	310	165	70	390
4	13	54.928	F <sub>2T</sub> <sup>(8)</sup> (N)		16,154		16,154	16,154	16,154	7,692	3,846	1,923	10,192
			T <sub>2B</sub> <sup>(9)</sup> (Nm)		420		420	420	420	200	100	50	265
	20	81.52	F <sub>2T</sub> <sup>(8)</sup> (N)		28,250		24,375	24,000	24,000	10,125	4,375	2,375	19,500
			T <sub>2B</sub> <sup>(9)</sup> (Nm)		1,130		975	960	960	405	175	95	780
	21	84.88	F <sub>2T</sub> <sup>(8)</sup> (N)		28,690		24,643	24,286	24,286	11,190	5,000	2,500	19,167
			T <sub>2B</sub> <sup>(9)</sup> (Nm)		1,205		1,035	1,020	1,020	470	210	105	805
24	97.616	F <sub>2T</sub> <sup>(8)</sup> (N)		28,542		24,479	24,063	24,063	13,542	6,979	2,813	18,854	
		T <sub>2B</sub> <sup>(9)</sup> (Nm)		1,370		1,175	1,155	1,155	650	335	135	905	
5	13	68.66	F <sub>2T</sub> <sup>(8)</sup> (N)	26,461	26,461		26,461	25,846	25,846		7,385	3,231	18,462
			T <sub>2B</sub> <sup>(9)</sup> (Nm)	860	860		860	840	840		240	105	600
	15	77.27	F <sub>2T</sub> <sup>(8)</sup> (N)	30,533	30,533		30,533	29,867	29,867		9,867	3,867	22,133
			T <sub>2B</sub> <sup>(9)</sup> (Nm)	1,145	1,145		1,145	1,120	1,120		370	145	830
	17	84.88	F <sub>2T</sub> <sup>(8)</sup> (N)	31,647	31,647		31,647	30,941	30,941		12,706	4,471	22,706
			T <sub>2B</sub> <sup>(9)</sup> (Nm)	1,345	1,345		1,345	1,315	1,315		540	190	965
19	95.49	F <sub>2T</sub> <sup>(8)</sup> (N)	39,368	39,368		39,368	38,947	38,947		15,052	5,158	31,053	
		T <sub>2B</sub> <sup>(9)</sup> (Nm)	1,870	1,870		1,870	1,850	1,850		715	245	1,745	
20	100.8	F <sub>2T</sub> <sup>(8)</sup> (N)	38,900	43,400		38,900	38,500	38,500		9,700	3,800	32,500	
		T <sub>2B</sub> <sup>(9)</sup> (Nm)	1,945	2,170		1,945	1,925	1,925		485	190	1,625	
6	13	82.392	F <sub>2T</sub> <sup>(8)</sup> (N)	38,974	38,974		38,974	38,462	38,462		12,179	4,872	29,487
			T <sub>2B</sub> <sup>(9)</sup> (Nm)	1,520	1,520		1,520	1,500	1,500		475	190	1,150
	14	88.764	F <sub>2T</sub> <sup>(8)</sup> (N)	44,286	44,286		44,286	43,929	43,929		13,690	6,548	34,881
			T <sub>2B</sub> <sup>(9)</sup> (Nm)	1,860	1,860		1,860	1,845	1,845		575	275	1,465
	16	95.496	F <sub>2T</sub> <sup>(8)</sup> (N)	39,271	39,271		39,271	38,646	38,646		17,917	6,979	29,792
			T <sub>2B</sub> <sup>(9)</sup> (Nm)	1,885	1,885		1,885	1,855	1,855		860	335	1,430
17	101.856	F <sub>2T</sub> <sup>(8)</sup> (N)	46,176	46,176		46,176	45,784	45,784		20,294	8,039	36,471	
		T <sub>2B</sub> <sup>(9)</sup> (Nm)	2,355	2,355		2,355	2,335	2,335		1,035	410	1,860	
8	13	109.856	F <sub>2T</sub> <sup>(8)</sup> (N)	70,769	70,769		70,769	70,769	70,769		25,962		59,615
			T <sub>2B</sub> <sup>(9)</sup> (Nm)	3,680	3,680		3,680	3,680	3,680		1,350		3,100

\* The Maximal Driving Torque is also to be understood as the Maximal Acceleration Torque T<sub>2B</sub>.

The Emergency Stop Torque T<sub>2NOT</sub> = 2 x T<sub>2B</sub>, under the condition limited 1000 times in the whole service period.

(1) Number of Teeth (5) Working Pitch Circle Diameter (in mm) (8) Maximum Feed-Force (9) Maximum Driving Torque

Note : The strength of screws is a limitation of the max. transmission torque. For Pinion Welded Plate, please refer to Page.40.

# Pinion with Straight Teeth ( Interface : Keyway )

Quality DIN 5 / Alloy Steel  
Tooth Thickness Tolerance : e25  
Straight Teeth  
Case-Hardened and Teeth Ground

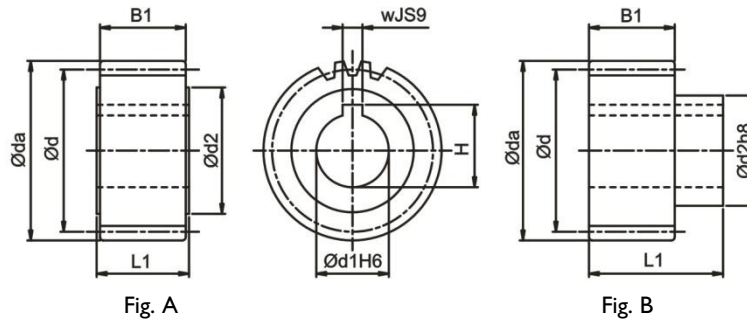

## Module 2

z <sup>(1)</sup>	x <sup>(2)</sup>	da <sup>(3)</sup>	d <sup>(4)</sup>	dw <sup>(5)</sup>	d1 H6	d2	B1	L1	w JS9	H	L <sup>(6)</sup>	Fig	Order code	
													Pinion	Shrink disc
16	0	36	32	32	15	25	28	30	5	17.3	100.531	A	F02116A15	
18	0	40	36	36	15	28	28	30	5	17.3	113.097	A	F02118A15	
18	0	40	36	36	20	28	28	30	6	22.8	113.097	A	F02118A20	
20	0	44	40	40	15	25	28	30	5	17.3	125.664	A	F02120A15	
20	0	44	40	40	19	30	28	30	6	21.8	125.664	A	F02120A19	
20	0	44	40	40	19	30	28	56	6	21.8	125.664	B	F02120B19	SSD-30
20	0	44	40	40	20	30	28	30	6	22.8	125.664	A	F02120A20	
20	0	44	40	40	22	30	28	30	6	24.8	125.664	A	F02120A22	
20	0	44	40	40	22	36	28	56	6	24.8	125.664	B	F02120B22	SSD-36
22	0	48	44	44	15	25	28	30	5	17.3	138.23	A	F02122A15	
22	0	48	44	44	19	30	28	30	6	21.8	138.23	A	F02122A19	
22	0	48	44	44	19	30	28	56	6	21.8	138.23	B	F02122B19	SSD-30
22	0	48	44	44	20	30	28	30	6	22.8	138.23	A	F02122A20	
22	0	48	44	44	22	30	28	30	6	24.8	138.23	A	F02122A22	
22	0	48	44	44	22	36	28	56	6	24.8	138.23	B	F02122B22	SSD-36
22	0	48	44	44	25	36	28	30	8	28.3	138.23	A	F02122A25	
25	0	54	50	50	15	25	28	30	5	17.3	157.08	A	F02125A15	
25	0	54	50	50	16	30	28	54	5	18.3	157.08	B	F02125B16	SSD-30
25	0	54	50	50	19	30	28	30	6	21.8	157.08	A	F02125A19	
25	0	54	50	50	19	30	28	56	6	21.8	157.08	B	F02125B19	SSD-30
25	0	54	50	50	20	30	28	30	6	22.8	157.08	A	F02125A20	
25	0	54	50	50	22	30	28	30	6	24.8	157.08	A	F02125A22	
25	0	54	50	50	22	36	28	56	6	24.8	157.08	B	F02125B22	SSD-36
25	0	54	50	50	25	36	28	30	8	28.3	157.08	A	F02125A25	
25	0	54	50	50	30	44	28	30	8	33.3	157.08	A	F02125A30	
28	0	60	56	56	15	25	28	30	5	17.3	175.929	A	F02128A15	
28	0	60	56	56	19	30	28	30	6	21.8	175.929	A	F02128A19	
28	0	60	56	56	19	30	28	56	6	21.8	175.929	B	F02128B19	SSD-30
28	0	60	56	56	20	30	28	30	6	22.8	175.929	A	F02128A20	
28	0	60	56	56	22	30	28	30	6	24.8	175.929	A	F02128A22	
28	0	60	56	56	22	36	28	56	6	24.8	175.929	B	F02128B22	SSD-36
28	0	60	56	56	25	36	28	30	8	28.3	175.929	A	F02128A25	
28	0	60	56	56	30	45	28	30	8	33.3	175.929	A	F02128A30	
28	0	60	56	56	30	50	28	60	8	33.3	175.929	B	F02128B30	SSD-50
28	0	60	56	56	35	48	28	30	10	38.3	175.929	A	F02128A35	

(1) Number of teeth (2) Profile modification factor (3) Diameter of addendum circle (4) Pitch circle diameter  
(5) Working pitch circle diameter (6) Pitch circle length  $L = \pi \times d$

# Pinion with Straight Teeth ( Interface : Keyway )

Quality DIN 5 / Alloy Steel  
Tooth Thickness Tolerance : e25  
Straight Teeth  
Case-Hardened and Teeth Ground

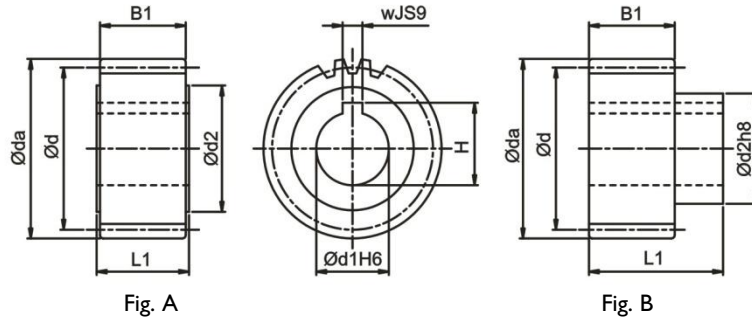

## Module 2

z <sup>(1)</sup>	x <sup>(2)</sup>	da <sup>(3)</sup>	d <sup>(4)</sup>	dw <sup>(5)</sup>	dl H6	d2	Bl	Ll	w JS9	H	L <sup>(6)</sup>	Fig	Order code	
													Pinion	Shrink disc
32	0	68	64	64	15	36	28	30	5	17.3	201.062	A	F02132A15	
32	0	68	64	64	16	30	28	54	5	18.3	201.062	B	F02132B16	SSD-30
32	0	68	64	64	20	30	28	30	6	22.8	201.062	A	F02132A20	
32	0	68	64	64	22	30	28	30	6	24.8	201.062	A	F02132A22	
32	0	68	64	64	22	36	28	56	6	24.8	201.062	B	F02132B22	SSD-36
32	0	68	64	64	25	36	28	30	8	28.3	201.062	A	F02132A25	
32	0	68	64	64	30	45	28	30	8	33.3	201.062	A	F02132A30	
32	0	68	64	64	30	50	28	60	8	33.3	201.062	B	F02132B30	SSD-50
32	0	68	64	64	32	55	28	65	10	35.3	201.062	B	F02132B32	SSD-55
32	0	68	64	64	35	48	28	30	10	38.3	201.062	A	F02132A35	
36	0	76	72	72	20	30	28	30	6	22.8	226.195	A	F02136A20	
36	0	76	72	72	25	36	28	30	8	28.3	226.195	A	F02136A25	
36	0	76	72	72	30	45	28	30	8	33.3	226.195	A	F02136A30	
36	0	76	72	72	35	48	28	30	10	38.3	226.195	A	F02136A35	
36	0	76	72	72	40	62	28	65	12	43.3	226.195	B	F02136B40	SSD-62
36	0	76	72	72	45	58	28	30	14	48.8	226.195	A	F02136A45	
40	0	84	80	80	15	36	28	30	5	17.3	251.327	A	F02140A15	
40	0	84	80	80	20	30	28	30	6	22.8	251.327	A	F02140A20	
40	0	84	80	80	25	36	28	30	8	28.3	251.327	A	F02140A25	
40	0	84	80	80	30	45	28	30	8	33.3	251.327	A	F02140A30	
40	0	84	80	80	32	55	28	65	10	35.3	251.327	B	F02140B32	SSD-55
40	0	84	80	80	35	48	28	30	10	38.3	251.327	A	F02140A35	
40	0	84	80	80	40	62	28	65	12	43.3	251.327	B	F02140B40	SSD-62
40	0	84	80	80	45	58	28	30	14	48.8	251.327	A	F02140A45	
40	0	84	80	80	45	68	28	65	14	48.8	251.327	B	F02140B45	SSD-68
45	0	94	90	90	20	30	28	30	6	22.8	282.743	A	F02145A20	
45	0	94	90	90	25	36	28	30	8	28.3	282.743	A	F02145A25	
45	0	94	90	90	35	48	28	30	10	38.3	282.743	A	F02145A35	
45	0	94	90	90	45	58	28	30	14	48.8	282.743	A	F02145A45	
50	0	104	100	100	20	30	28	30	6	22.8	314.159	A	F02150A20	
50	0	104	100	100	25	36	28	30	8	28.3	314.159	A	F02150A25	
50	0	104	100	100	35	48	28	30	10	38.3	314.159	A	F02150A35	
50	0	104	100	100	45	58	28	30	14	48.8	314.159	A	F02150A45	
50	0	104	100	100	45	68	28	65	14	48.8	314.159	B	F02150B45	SSD-68
56	0	116	112	112	25	36	28	30	8	28.3	351.858	A	F02156A25	
56	0	116	112	112	35	48	28	30	10	38.3	351.858	A	F02156A35	
63	0	130	126	126	25	36	28	30	8	28.3	395.841	A	F02163A25	
71	0	146	142	142	35	48	28	30	10	38.3	446.106	A	F02171A35	
80	0	164	160	160	35	48	28	30	10	38.3	502.655	A	F02180A35	
90	0	184	180	180	45	58	28	30	14	48.8	565.487	A	F02190A45	



Quality DIN 5 / Alloy Steel  
 Tooth Thickness Tolerance : e25  
 Straight Teeth  
 Case-Hardened and Teeth Ground

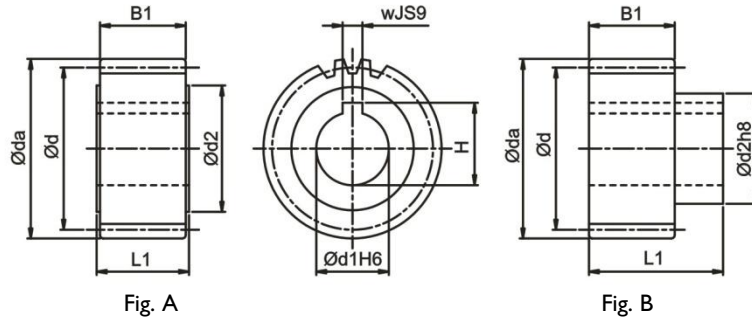

Module 3

z <sup>(1)</sup>	x <sup>(2)</sup>	da <sup>(3)</sup>	d <sup>(4)</sup>	dw <sup>(5)</sup>	d1 H6	d2	B1	L1	w JS9	H	L <sup>(6)</sup>	Fig	Order code	
													Pinion	Shrink disc
18	0	60	54	54	25	36	28	30	8	28.3	169.646	A	F03118A25	
20	0	66	60	60	25	36	28	30	8	28.3	188.496	A	F03120A25	
20	0	66	60	60	30	45	28	30	8	33.3	188.496	A	F03120A30	
20	0	66	60	60	35	48	28	30	10	38.3	188.496	A	F03120A35	
22	0	72	66	66	22	36	28	56	6	24.8	207.345	B	F03122B22	SSD-36
22	0	72	66	66	25	36	28	30	8	28.3	207.345	A	F03122A25	
22	0	72	66	66	25	44	28	60	8	28.3	207.345	B	F03122B25	SSD-44
22	0	72	66	66	30	45	28	30	8	33.3	207.345	A	F03122A30	
22	0	72	66	66	30	50	28	60	8	33.3	207.345	B	F03122B30	SSD-50
22	0	72	66	66	32	55	28	65	10	35.3	207.345	B	F03122B32	SSD-55
22	0	72	66	66	35	48	28	30	10	38.3	207.345	A	F03122A35	
22	0	72	66	66	35	55	28	65	10	38.3	207.345	B	F03122B35	SSD-55
22	0	72	66	66	40	62	28	65	12	43.3	207.345	B	F03122B40	SSD-62
25	0	81	75	75	25	36	28	30	8	28.3	235.619	A	F03125A25	
25	0	81	75	75	30	45	28	30	8	33.3	235.619	A	F03125A30	
25	0	81	75	75	32	55	28	65	10	35.3	235.619	B	F03125B32	SSD-55
25	0	81	75	75	35	48	28	30	10	38.3	235.619	A	F03125A35	
25	0	81	75	75	40	62	28	65	12	43.3	235.619	B	F03125B40	SSD-62
25	0	81	75	75	45	58	28	30	14	48.8	235.619	A	F03125A45	
28	0	90	84	84	22	36	28	56	6	24.8	263.894	B	F03128B22	SSD-36
28	0	90	84	84	25	36	28	30	8	28.3	263.894	A	F03128A25	
28	0	90	84	84	25	44	28	60	8	28.3	263.894	B	F03128B25	SSD-44
28	0	90	84	84	30	45	28	30	8	33.3	263.894	A	F03128A30	
28	0	90	84	84	30	50	28	60	8	33.3	263.894	B	F03128B30	SSD-50
28	0	90	84	84	32	55	28	65	10	35.3	263.894	B	F03128B32	SSD-55
28	0	90	84	84	35	48	28	30	10	38.3	263.894	A	F03128A35	
28	0	90	84	84	35	55	28	65	10	38.3	263.894	B	F03128B35	SSD-55
28	0	90	84	84	40	62	28	65	12	43.3	263.894	B	F03128B40	SSD-62
28	0	90	84	84	45	58	28	30	14	48.8	263.894	A	F03128A45	
28	0	90	84	84	45	68	28	65	14	48.8	263.894	B	F03128B45	SSD-68

(1) Number of teeth (2) Profile modification factor (3) Diameter of addendum circle (4) Pitch circle diameter  
 (5) Working pitch circle diameter (6) Pitch circle length  $L = \pi \times d$

# Pinion with Straight Teeth ( Interface : Keyway )

Quality DIN 5 / Alloy Steel  
Tooth Thickness Tolerance : e25  
Straight Teeth  
Case-Hardened and Teeth Ground

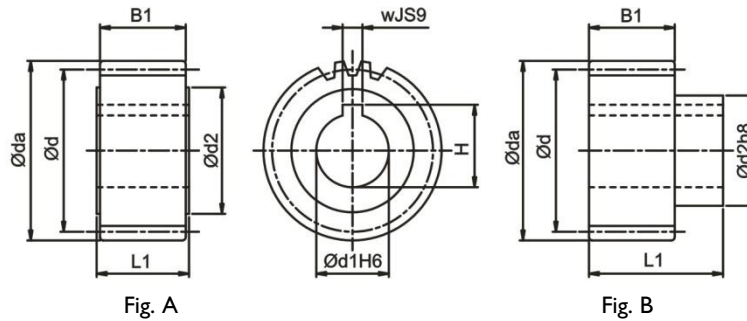

## Module 3

z <sup>(1)</sup>	x <sup>(2)</sup>	da <sup>(3)</sup>	d <sup>(4)</sup>	dw <sup>(5)</sup>	d1 H6	d2	B1	L1	w JS9	H	L <sup>(6)</sup>	Fig	Order code	
													Pinion	Shrink disc
32	0	102	96	96	25	36	28	30	8	28.3	301.593	A	F03132A25	
32	0	102	96	96	30	45	28	30	8	33.3	301.593	A	F03132A30	
32	0	102	96	96	32	55	28	65	10	35.3	301.593	B	F03132B32	SSD-55
32	0	102	96	96	35	48	28	30	10	38.3	301.593	A	F03132A35	
32	0	102	96	96	40	62	28	65	12	43.3	301.593	B	F03132B40	SSD-62
32	0	102	96	96	45	58	28	30	14	48.8	301.593	A	F03132A45	
32	0	102	96	96	60	80	28	30	18	64.4	301.593	A	F03132A60	
36	0	114	108	108	25	36	28	30	8	28.3	339.292	A	F03136A25	
36	0	114	108	108	35	48	28	30	10	38.3	339.292	A	F03136A35	
36	0	114	108	108	45	58	28	30	14	48.8	339.292	A	F03136A45	
36	0	114	108	108	45	68	28	65	14	48.8	339.292	B	F03136B45	SSD-68
36	0	114	108	108	60	80	28	30	18	64.4	339.292	A	F03136A60	
40	0	126	120	120	25	36	28	30	8	28.3	376.991	A	F03140A25	
40	0	126	120	120	35	48	28	30	10	38.3	376.991	A	F03140A35	
40	0	126	120	120	45	58	28	30	14	48.8	376.991	A	F03140A45	
40	0	126	120	120	60	80	28	30	18	64.4	376.991	A	F03140A60	
45	0	141	135	135	25	36	28	30	8	28.3	424.115	A	F03145A25	
45	0	141	135	135	35	48	28	30	10	38.3	424.115	A	F03145A35	
45	0	141	135	135	45	58	28	30	14	48.8	424.115	A	F03145A45	
45	0	141	135	135	60	80	28	30	18	64.4	424.115	A	F03145A60	
50	0	156	150	150	35	48	28	30	10	38.3	471.239	A	F03150A35	
50	0	156	150	150	45	58	28	30	14	48.8	471.239	A	F03150A45	
56	0	174	168	168	45	58	28	30	14	48.8	527.788	A	F03156A45	
63	0	195	189	189	45	58	28	30	14	48.8	593.761	A	F03163A45	
63	0	195	189	189	60	80	28	30	18	64.4	593.761	A	F03163A60	

Quality DIN 5 / Alloy Steel  
 Tooth Thickness Tolerance : e25  
 Straight Teeth  
 Case-Hardened and Teeth Ground

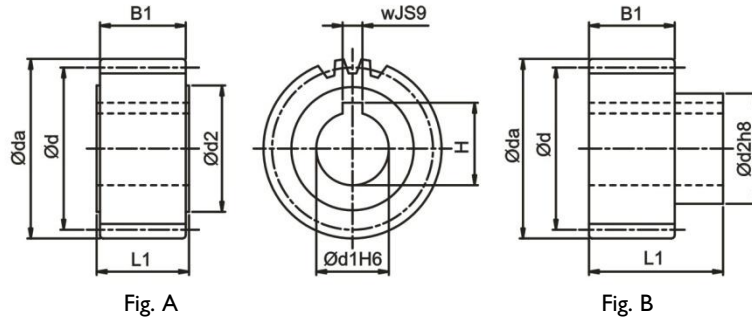

Module 4

z <sup>(1)</sup>	x <sup>(2)</sup>	da <sup>(3)</sup>	d <sup>(4)</sup>	dw <sup>(5)</sup>	dl <sub>H6</sub>	d2	B1	L1	w <sub>JS9</sub>	H	L <sup>(6)</sup>	Fig	Order code	
													Pinion	Shrink disc
20	0	88	80	80	32	55	40	75	10	35.3	251.327	B	F04120B32	SSD-55
20	0	88	80	80	35	52	40	50	10	38.3	251.327	A	F04120A35	
20	0	88	80	80	35	55	40	75	10	38.3	251.327	B	F04120B35	SSD-55
20	0	88	80	80	40	62	40	75	12	43.3	251.327	B	F04120B40	SSD-62
20	0	88	80	80	45	65	40	50	14	48.8	251.327	A	F04120A45	
22	0	96	88	88	35	52	40	50	10	38.3	276.46	A	F04122A35	
22	0	96	88	88	45	65	40	50	14	48.8	276.46	A	F04122A45	
22	0	96	88	88	45	68	40	75	14	48.8	276.46	B	F04122B45	SSD-68
25	0	108	100	100	32	55	40	75	10	35.3	314.159	B	F04125B32	SSD-55
25	0	108	100	100	35	52	40	50	10	38.3	314.159	A	F04125A35	
25	0	108	100	100	35	55	40	75	10	38.3	314.159	B	F04125B35	SSD-55
25	0	108	100	100	40	62	40	75	12	43.3	314.159	B	F04125B40	SSD-62
25	0	108	100	100	45	65	40	50	14	48.8	314.159	A	F04125A45	
25	0	108	100	100	55	80	40	80	16	59.3	314.159	B	F04125B55	SSD-80
28	0	120	112	112	35	52	40	50	10	38.3	351.858	A	F04128A35	
28	0	120	112	112	45	65	40	50	14	48.8	351.858	A	F04128A45	
28	0	120	112	112	45	68	40	75	14	48.8	351.858	B	F04128B45	SSD-68
32	0	136	128	128	35	52	40	50	10	38.3	402.124	A	F04132A35	
32	0	136	128	128	45	65	40	50	14	48.8	402.124	A	F04132A45	
32	0	136	128	128	55	80	40	80	16	59.3	402.124	B	F04132B55	SSD-80
32	0	136	128	128	75	110	40	100	20	79.9	402.124	B	F04132B75	SSD-110
40	0	168	160	160	45	65	40	50	14	48.8	502.655	A	F04140A45	
40	0	168	160	160	60	80	40	50	18	64.4	502.655	A	F04140A60	
40	0	168	160	160	75	110	40	100	20	79.9	502.655	B	F04140B75	SSD-110

Module 5

z <sup>(1)</sup>	x <sup>(2)</sup>	da <sup>(3)</sup>	d <sup>(4)</sup>	dw <sup>(5)</sup>	dl <sub>H6</sub>	d2	B1	L1	w <sub>JS9</sub>	H	L <sup>(6)</sup>	Fig	Order code	
													Pinion	Shrink disc
21	0	115	105	105	45	68	50	85	14	48.8	329.867	B	F05121B45	SSD-68
21	0	115	105	105	55	80	50	90	16	59.3	329.867	B	F05121B55	SSD-80
25	0	135	125	125	45	68	50	85	14	48.8	392.699	B	F05125B45	SSD-68
25	0	135	125	125	55	80	50	90	16	59.3	392.699	B	F05125B55	SSD-80
25	0	135	125	125	75	110	50	110	20	79.9	392.699	B	F05125B75	SSD-110

(1) Number of teeth (2) Profile modification factor (3) Diameter of addendum circle (4) Pitch circle diameter  
 (5) Working pitch circle diameter (6) Pitch circle length  $L = \pi \times d$

# Pinion with Straight Teeth

( Interface : Keyway )

Quality DIN 5 / Alloy Steel  
 Tooth Thickness Tolerance : e25 \*\*  
 Straight Teeth  
 Case-Hardened and Teeth Ground

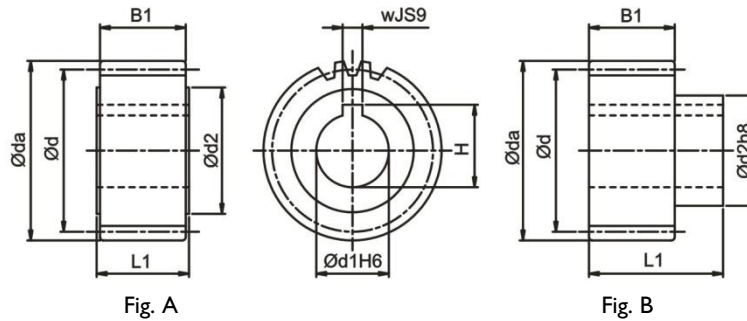

## Module 6

z <sup>(1)</sup>	x <sup>(2)</sup>	da <sup>(3)</sup>	d <sup>(4)</sup>	dw <sup>(5)</sup>	d1 H6	d2	B1	L1	w JS9	H	L <sup>(6)</sup>	Fig	Order code	
													Pinion	Shrink disc
21	0	138	126	126	55	80	60	100	16	59.3	395.841	B	F06121B55	SSD-80
21	0	138	126	126	75	110	60	120	20	79.9	395.841	B	F06121B75	SSD-110
25	0	162	150	150	55	80	60	100	16	59.3	471.239	B	F06125B55	SSD-80
25	0	162	150	150	75	110	60	120	20	79.9	471.239	B	F06125B75	SSD-110

## Module 8

z <sup>(1)</sup>	x <sup>(2)</sup>	da <sup>(3)</sup>	d <sup>(4)</sup>	dw <sup>(5)</sup>	d1 H6	d2	B1	L1	w JS9	H	L <sup>(6)</sup>	Fig	Order code	
													Pinion	Shrink disc
20	0	176	160	160	75	110	80	140	20	79.9	502.655	B	F08120B75	SSD-110
20	0	176	160	160	85	125	80	145	22	90.4	502.655	B	F08120B85	SSD-125

## Module 10

z <sup>(1)</sup>	x <sup>(2)</sup>	da <sup>(3)</sup>	d <sup>(4)</sup>	dw <sup>(5)</sup>	d1 H6	d2	B1	L1	w JS9	H	L <sup>(6)</sup>	Fig	Order code	
													Pinion	Shrink disc
20	0	220	200	200	85	125	100	165	22	90.4	628.319	B	F10120B85	SSD-125

\*\* By Module 8 or 10, the Tooth Thickness Tolerance = f 23.

- (1) Number of teeth (2) Profile modification factor (3) Diameter of addendum circle  
 (4) Pitch circle diameter (5) Working pitch circle diameter (6) Pitch circle length  $L = \pi \times d$

Pinion material carburized, the surface hardness reached 60 HRc  
 Teeth surface ground in order to reduce noise and improve wear resistance  
 Accessories include hexagon socket head cap screws (Strength 12.9 , DIN 912)

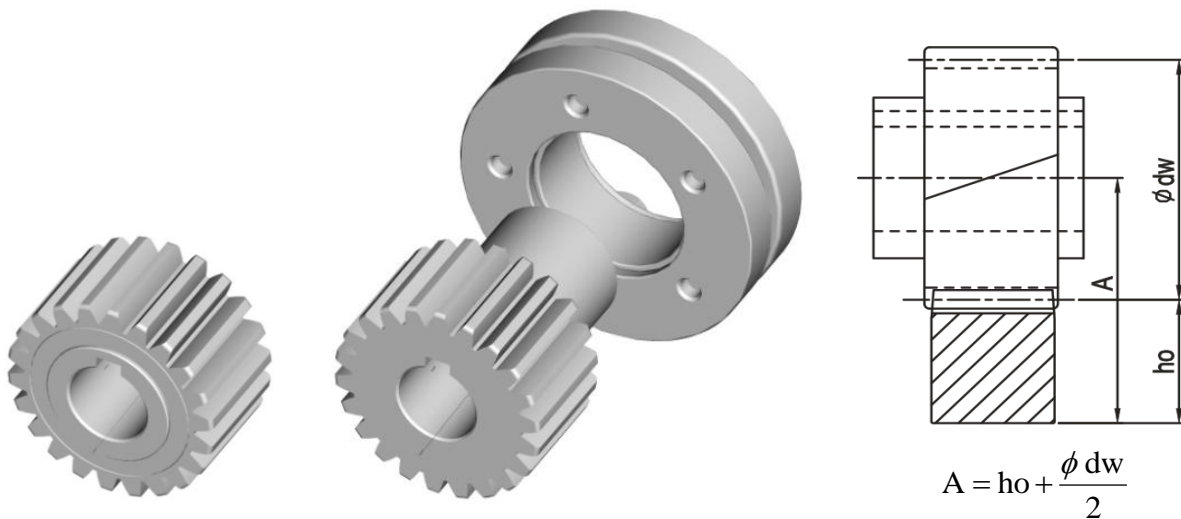

In Table 9, the maximum permissible torque of pinion with Keyway, and the rack is calculated on the basis of a speed of 1.5 m/s and providing good lubrication (using an automatic lubrication system or manually applied grease every day), the tooth root strength factor  $S_F \geq 1.4$ , tooth surface strength coefficient  $S_H \geq 1$ , the safety factor  $S_B \cong 1$ , and the required service life of 20,000 hours. By higher speed, the max. permissible torque reduced. The user needs to increase the safety factor for the application. Backlash changes by different center height. Please contact APEX under [WWW.APEXDYNA.COM](http://WWW.APEXDYNA.COM).

# Pinion with Straight Teeth ( Interface : Keyway )

Table 9. The max. permitted torque and feed-force of pinion with Keyway

Pinion			Rack		Quality	Q4	Q5H	Q5		Q6	Q6M	Q8H	Q8	Q9	Q10
			Material	Carbon Steel	Alloy Steel		Carbon Steel	Carbon Steel	Carbon Steel	Q&T Alloy Steel	Carbon Steel	Stainless Steel	Carbon Steel		
			Heat Treatment	Induction Hardening	Case Hardening	Carburized Induction	Induction Hardening	Induction Hardening	Induction Hardening	Quenched Tempered	Normalizing	Solution	Induction Hardening		
Mn	z <sup>(1)</sup>	dw <sup>(5)</sup>	Max. Torque * and Feed-Force												
2	16	32	F <sub>2T</sub> <sup>(8)</sup> (N)		4,375	4,375		4,375	4,375	1,875	1,250	625	1,563		
			T <sub>2B</sub> <sup>(9)</sup> (Nm)		70	70		70	70	30	20	10	25		
	18	36	F <sub>2T</sub> <sup>(8)</sup> (N)		5,556	5,556		5,556	5,556	1,944	1,389	556	1,944		
			T <sub>2B</sub> <sup>(9)</sup> (Nm)		100	100		100	100	35	25	10	35		
	20	40	F <sub>2T</sub> <sup>(8)</sup> (N)		5,250	5,250		7,000	7,000	1,500	1,000	500	2,250		
			T <sub>2B</sub> <sup>(9)</sup> (Nm)		105	105		140	140	30	20	10	45		
	22	44	F <sub>2T</sub> <sup>(8)</sup> (N)		8,182	8,182		7,045	7,045	1,591	1,136	682	2,273		
			T <sub>2B</sub> <sup>(9)</sup> (Nm)		180	180		155	155	35	25	15	50		
	25	50	F <sub>2T</sub> <sup>(8)</sup> (N)		8,400	8,400		7,200	7,200	2,000	1,200	800	2,200		
			T <sub>2B</sub> <sup>(9)</sup> (Nm)		210	210		180	180	50	30	20	55		
	28	56	F <sub>2T</sub> <sup>(8)</sup> (N)		8,571	8,571		7,143	7,143	2,143	1,429	714	2,321		
			T <sub>2B</sub> <sup>(9)</sup> (Nm)		240	240		200	200	60	40	20	65		
	32	64	F <sub>2T</sub> <sup>(8)</sup> (N)		8,594	8,594		7,188	7,188	2,656	1,719	781	2,188		
			T <sub>2B</sub> <sup>(9)</sup> (Nm)		275	275		230	230	85	55	25	70		
	36	72	F <sub>2T</sub> <sup>(8)</sup> (N)		8,611	8,611		7,222	7,222	3,472	2,083	694	2,222		
			T <sub>2B</sub> <sup>(9)</sup> (Nm)		310	310		260	260	125	75	25	80		
	40	80	F <sub>2T</sub> <sup>(8)</sup> (N)		8,750	8,750		7,125	7,125	3,375	2,250	750	2,125		
			T <sub>2B</sub> <sup>(9)</sup> (Nm)		350	350		285	285	135	90	30	85		
	45	90	F <sub>2T</sub> <sup>(8)</sup> (N)		8,667	8,667		7,111	7,111	3,333	2,333	667	2,111		
			T <sub>2B</sub> <sup>(9)</sup> (Nm)		390	390		320	320	150	105	30	95		
50	100	F <sub>2T</sub> <sup>(8)</sup> (N)		8,700	8,700		7,000	7,000	3,200	2,300	700	2,100			
		T <sub>2B</sub> <sup>(9)</sup> (Nm)		435	435		350	350	160	115	35	105			
56	112	F <sub>2T</sub> <sup>(8)</sup> (N)		8,750	8,750		6,964	6,964	3,214	2,321	714	2,054			
		T <sub>2B</sub> <sup>(9)</sup> (Nm)		490	490		390	390	180	130	40	115			
63	126	F <sub>2T</sub> <sup>(8)</sup> (N)		8,889	8,889		6,825	6,825	3,016	2,222	714	2,063			
		T <sub>2B</sub> <sup>(9)</sup> (Nm)		560	560		430	430	190	140	45	130			
71	142	F <sub>2T</sub> <sup>(8)</sup> (N)		9,085	9,085		6,901	6,901	3,169	2,254	704	2,042			
		T <sub>2B</sub> <sup>(9)</sup> (Nm)		645	645		490	490	225	160	50	145			
80	160	F <sub>2T</sub> <sup>(8)</sup> (N)		9,313	9,313		7,000	7,000	3,250	2,313	750	2,063			
		T <sub>2B</sub> <sup>(9)</sup> (Nm)		745	745		560	560	260	185	60	165			
90	180	F <sub>2T</sub> <sup>(8)</sup> (N)		9,444	9,444		7,167	7,167	3,389	2,333	722	2,056			
		T <sub>2B</sub> <sup>(9)</sup> (Nm)		850	850		645	645	305	210	65	185			
3	18	54	F <sub>2T</sub> <sup>(8)</sup> (N)		11,481	11,481		11,111	11,111	4,630	2,222	1,296	3,704		
			T <sub>2B</sub> <sup>(9)</sup> (Nm)		310	310		300	300	125	60	35	100		
	20	60	F <sub>2T</sub> <sup>(8)</sup> (N)		13,667	13,667		13,333	13,333	2,833	1,833	1,000	5,167		
			T <sub>2B</sub> <sup>(9)</sup> (Nm)		410	410		400	400	85	55	30	155		
	22	66	F <sub>2T</sub> <sup>(8)</sup> (N)		15,152	15,152		13,636	13,636	3,333	1,970	1,061	6,667		
			T <sub>2B</sub> <sup>(9)</sup> (Nm)		500	500		450	450	110	65	35	220		
	25	75	F <sub>2T</sub> <sup>(8)</sup> (N)		15,600	15,600		13,600	13,600	4,800	2,400	1,333	6,667		
			T <sub>2B</sub> <sup>(9)</sup> (Nm)		585	585		510	510	180	90	50	250		

\* The Maximal Driving Torque is also to be understood as the Maximal Acceleration Torque T<sub>2B</sub>.

The Emergency Stop Torque T<sub>2NOT</sub> = 2 × T<sub>2B</sub>, under the condition limited 1000 times in the whole service period.

(1) Number of Teeth    (5) Working Pitch Circle Diameter (in mm)    (8) Maximum Feed-Force    (9) Maximum Driving Torque

Table 9. The max. permitted torque and feed-force of pinion with Keyway

Pinion			Rack		Quality	Q4	Q5H	Q5		Q6	Q6M	Q8H	Q8	Q9	Q10
			Material	Carbon Steel	Alloy Steel		Carbon Steel	Carbon Steel	Carbon Steel	Carbon Steel	Q&T Alloy Steel	Carbon Steel	Stainless Steel	Carbon Steel	
			Heat Treatment	Induction Hardening	Case Hardening	Carburized Induction	Induction Hardening	Induction Hardening	Induction Hardening	Quenched Tempered	Normalizing	Solution	Induction Hardening		
Mn	z <sup>(1)</sup>	dw <sup>(5)</sup>	Max. Torque * and Feed-Force												
3	28	84	F <sub>2T</sub> <sup>(8)</sup> (N)		15,833	15,833		13,690	13,690	6,310	2,738	1,429	6,429		
			T <sub>2B</sub> <sup>(9)</sup> (Nm)		665	665		575	575	265	115	60	270		
	32	96	F <sub>2T</sub> <sup>(8)</sup> (N)		16,146	16,146		13,646	13,646	8,438	3,542	1,354	6,146		
			T <sub>2B</sub> <sup>(9)</sup> (Nm)		775	775		655	655	405	170	65	295		
	36	108	F <sub>2T</sub> <sup>(8)</sup> (N)		16,389	16,389		13,704	13,704	8,981	4,722	1,389	5,833		
			T <sub>2B</sub> <sup>(9)</sup> (Nm)		885	885		740	740	485	255	75	315		
	40	120	F <sub>2T</sub> <sup>(8)</sup> (N)		16,500	16,500		13,833	13,833	9,000	6,167	1,333	5,833		
			T <sub>2B</sub> <sup>(9)</sup> (Nm)		990	990		830	830	540	370	80	350		
	45	135	F <sub>2T</sub> <sup>(8)</sup> (N)		16,593	16,593		14,148	14,148	9,259	6,667	1,333	5,852		
			T <sub>2B</sub> <sup>(9)</sup> (Nm)		1,120	1,120		955	955	625	450	90	395		
	50	150	F <sub>2T</sub> <sup>(8)</sup> (N)		16,733	16,733		14,400	14,400	9,533	6,800	1,400	5,933		
			T <sub>2B</sub> <sup>(9)</sup> (Nm)		1,255	1,255		1,080	1,080	715	510	105	445		
	56	168	F <sub>2T</sub> <sup>(8)</sup> (N)		16,786	16,786		14,643	14,643	9,762	6,964	1,369	6,012		
			T <sub>2B</sub> <sup>(9)</sup> (Nm)		1,410	1,410		1,230	1,230	820	585	115	505		
63	189	F <sub>2T</sub> <sup>(8)</sup> (N)		16,825	16,825		14,656	14,656	10,053	6,825	1,376	5,820			
		T <sub>2B</sub> <sup>(9)</sup> (Nm)		1,590	1,590		1,385	1,385	950	645	130	550			
4	20	80	F <sub>2T</sub> <sup>(8)</sup> (N)		26,125		25,000	24,625	24,625	7,125	3,625	1,750	1,187		
			T <sub>2B</sub> <sup>(9)</sup> (Nm)		1,045		1,000	985	985	285	145	70	475		
	22	88	F <sub>2T</sub> <sup>(8)</sup> (N)		29,091		25,114	24,659	24,659	8,864	4,091	2,045	11,932		
			T <sub>2B</sub> <sup>(9)</sup> (Nm)		1,280		1,105	1,085	1,085	390	180	90	525		
	25	100	F <sub>2T</sub> <sup>(8)</sup> (N)		29,300		25,200	24,800	24,800	11,900	5,300	2,200	11,300		
			T <sub>2B</sub> <sup>(9)</sup> (Nm)		1,465		1,260	1,240	1,240	595	265	110	565		
	28	112	F <sub>2T</sub> <sup>(8)</sup> (N)		29,375		25,268	24,821	24,821	15,089	6,518	2,143	11,161		
			T <sub>2B</sub> <sup>(9)</sup> (Nm)		1,645		1,415	1,390	1,390	845	365	120	625		
	32	128	F <sub>2T</sub> <sup>(8)</sup> (N)		30,000		25,781	25,391	25,391	16,953	8,594	2,188	11,250		
			T <sub>2B</sub> <sup>(9)</sup> (Nm)		1,920		1,650	1,625	1,625	1,085	550	140	720		
	40	160	F <sub>2T</sub> <sup>(8)</sup> (N)		31,188		26,813	26,438	26,438	17,813	12,438	2,250	11,563		
			T <sub>2B</sub> <sup>(9)</sup> (Nm)		2,495		2,145	2,115	2,115	1,425	995	180	925		
	5	21	105	F <sub>2T</sub> <sup>(8)</sup> (N)	39,333	44,762		39,333	39,048	39,048		17,813	3,238	23,714	
				T <sub>2B</sub> <sup>(9)</sup> (Nm)	2,065	2,350		2,065	2,050	2,050		390	170	1,245	
25		125	F <sub>2T</sub> <sup>(8)</sup> (N)	40,160	46,640		40,160	39,760	39,760		10,640	3,440	23,280		
			T <sub>2B</sub> <sup>(9)</sup> (Nm)	2,510	2,915		2,510	2,485	2,485		665	215	1,455		
6	21	126	F <sub>2T</sub> <sup>(8)</sup> (N)	57,143	64,206		57,143	57,143	57,143		13,651	4,921	40,794		
			T <sub>2B</sub> <sup>(9)</sup> (Nm)	3,600	4,045		3,600	3,600	3,600		860	310	2,570		
	25	150	F <sub>2T</sub> <sup>(8)</sup> (N)	59,133	66,533		59,133	59,067	59,067		20,067	5,200	41,333		
			T <sub>2B</sub> <sup>(9)</sup> (Nm)	4,435	4,990		4,435	4,430	4,430		1,505	390	3,100		
8	20	160	F <sub>2T</sub> <sup>(8)</sup> (N)	103,750	110,250		103,750	103,750	103,750		27,938		81,250		
			T <sub>2B</sub> <sup>(9)</sup> (Nm)	8,300	8,820		8,300	8,300	8,300		2,235		6,500		
10	20	200	F <sub>2T</sub> <sup>(8)</sup> (N)	165,400	169,200		165,400	165,300			55,850		145,200		
			T <sub>2B</sub> <sup>(9)</sup> (Nm)	16,540	16,920		16,540	16,530			5,585		14,520		

\* The Maximal Driving Torque is also to be understood as the Maximal Acceleration Torque T<sub>2B</sub>.

The Emergency Stop Torque T<sub>2NOT</sub> = 2 x T<sub>2B</sub>, under the condition limited 1000 times in the whole service period.

(1) Number of Teeth (5) Working Pitch Circle Diameter (in mm) (8) Maximum Feed-Force (9) Maximum Driving Torque

# Pinion with Straight Teeth

( Interface : Keyway / CP System )

Quality DIN 5 / Alloy Steel  
 Tooth Thickness Tolerance : e25  
 Straight Teeth  
 Case-Hardened and Teeth Ground

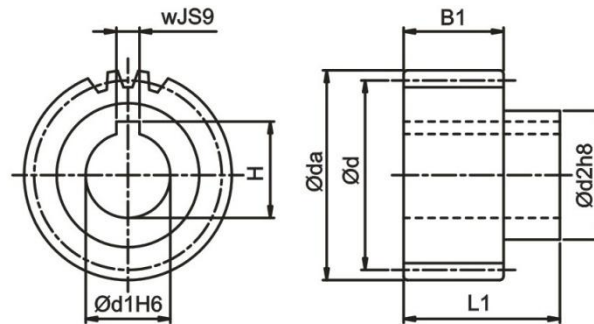

## Pitch 5 (Module : 1.591)

z <sup>(1)</sup>	x <sup>(2)</sup>	da <sup>(3)</sup>	d <sup>(4)</sup>	dw <sup>(5)</sup>	d1 H6	d2	B1	L1	w JS9	H	L <sup>(6)</sup>	Order code	
												Pinion	Shrink disc
25	0	42.971	39.788	39.788	16	30	25	51	5	18.3	124.996	FIK125B16	SSD-30
30	0	50.928	47.745	47.745	22	36	25	54	6	24.8	149.995	FIK130B22	SSD-36
40	0	66.843	63.66	63.66	25	44	25	56	8	28.3	199.994	FIK140B25	SSD-44

## Pitch 10 (Module : 3.183)

z <sup>(1)</sup>	x <sup>(2)</sup>	da <sup>(3)</sup>	d <sup>(4)</sup>	dw <sup>(5)</sup>	d1 H6	d2	B1	L1	w JS9	H	L <sup>(6)</sup>	Order code	
												Pinion	Shrink disc
20	0	70.028	63.661	63.662	22	36	31	60	6	24.8	200	F3B120B22	SSD-36
25	0	85.944	79.578	79.578	25	44	31	62	8	28.3	250	F3B125B25	SSD-44
25	0	85.944	79.578	79.578	32	55	31	68	10	35.3	250	F3B125B32	SSD-55

## Pitch 13.33 (Module : 4.244)

z <sup>(1)</sup>	x <sup>(2)</sup>	da <sup>(3)</sup>	d <sup>(4)</sup>	dw <sup>(5)</sup>	d1 H6	d2	B1	L1	w JS9	H	L <sup>(6)</sup>	Order code	
												Pinion	Shrink disc
20	0	93.368	84.88	84.88	32	55	40	77	10	35.3	266.658	F4D120B32	SSD-55
25	0	114.588	106.1	106.1	40	62	40	77	12	43.3	333.323	F4D125B40	SSD-62

(1) Number of teeth    (2) Profile modification factor    (3) Diameter of addendum circle    (4) Pitch circle diameter  
 (5) Working pitch circle diameter    (6) Pitch circle length  $L = \pi \times d$

Pinion material carburized, the surface hardness reached 60 HRC  
 Teeth surface ground in order to reduce noise and improve wear resistance  
 Accessories include hexagon socket head cap screws ( Strength 12.9 · DIN 912 )



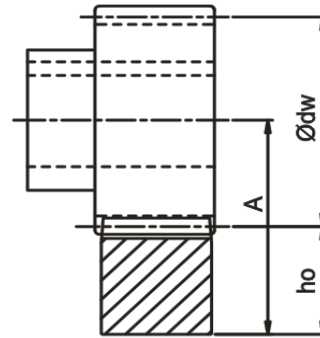
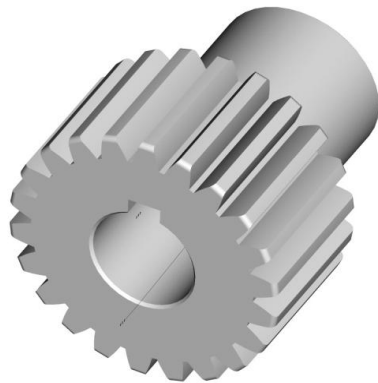

$$A = h_o + \frac{\phi dw}{2}$$

In Table 10, the maximum permissible torque of CP pinion, and the rack is calculated on the basis of a speed of 1.5 m/s and providing good lubrication (using an automatic lubrication system or manually applied grease every day), the tooth root strength factor  $S_F \geq 1.4$ , tooth surface strength coefficient  $S_H \geq 1$ , the safety factor  $S_B \cong 1$ , and the required service life of 20,000 hours. By higher speed, the max. permissible torque reduced. The user needs to increase the safety factor for the application. Backlash changes by different center height. Please contact APEX under WWW.APEXDYNA.COM.

Table 10. The max. permitted torque and feed-force of CP pinion with Keyway

Rack \ Pinion			Teeth Width (in mm)	Quality	Q6	Q8
				Material	Carbon Steel	Carbon Steel
Pitch $z^{(1)}$ $dw^{(5)}$				Heat Treatment	Induction Hardening	Normalizing
				Max. Torque and Feed-Force		
5	25	39.788	19 (Q6)	$F_{2T}^{(8)}$ (N)	4,524	754
			20 (Q8)	$T_{2B}^{(9)}$ (Nm)	90	15
			24 (Q6)	$F_{2T}^{(8)}$ (N)	5,781	1,005
			25 (Q8)	$T_{2B}^{(9)}$ (Nm)	115	20
	30	47.745	19 (Q6)	$F_{2T}^{(8)}$ (N)	4,398	1,047
			20 (Q8)	$T_{2B}^{(9)}$ (Nm)	105	25
			24 (Q6)	$F_{2T}^{(8)}$ (N)	5,864	1,257
			25 (Q8)	$T_{2B}^{(9)}$ (Nm)	140	30
	40	63.66	19 (Q6)	$F_{2T}^{(8)}$ (N)	4,398	1,414
			20 (Q8)	$T_{2B}^{(9)}$ (Nm)	140	45
			24 (Q6)	$F_{2T}^{(8)}$ (N)	5,655	1,728
			25 (Q8)	$T_{2B}^{(9)}$ (Nm)	180	55
10	20	63.662	29 (Q6)	$F_{2T}^{(8)}$ (N)	14,451	2,042
			30 (Q8)	$T_{2B}^{(9)}$ (Nm)	460	65
	25	79.578	29 (Q6)	$F_{2T}^{(8)}$ (N)	14,451	2,765
			30 (Q8)	$T_{2B}^{(9)}$ (Nm)	575	110
13.33	20	84.88	39 (Q6)	$F_{2T}^{(8)}$ (N)	26,272	4,123
			40 (Q8)	$T_{2B}^{(9)}$ (Nm)	1,115	175
	25	106.1	39 (Q6)	$F_{2T}^{(8)}$ (N)	26,390	6,221
			40 (Q8)	$T_{2B}^{(9)}$ (Nm)	1,400	330

\* The Maximal Driving Torque is also to be understood as the Maximal Acceleration Torque  $T_{2B}$ .  
The Emergency Stop Torque  $T_{2NOT} = 2 \times T_{2B}$ , under the condition limited 1000 times in the whole service period.  
(1) Number of Teeth    (5) Working Pitch Circle Diameter (in mm)    (8) Maximum Feed-Force    (9) Maximum Driving Torque

# Accessory

## Shrink Disc for Pinion with Keyway

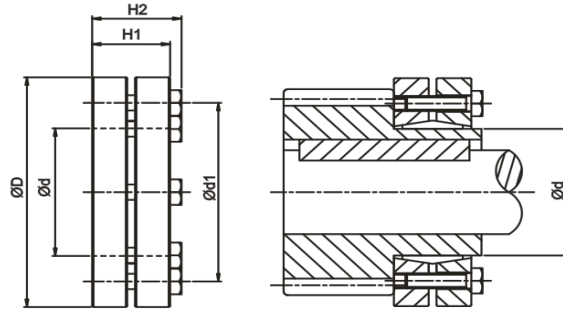

d	dI	D	H1	H2	Screw <sup>(1)</sup>	T <sub>A</sub> <sup>(2)</sup>	J	Order code
					No. x Type	Nm	Kg.m <sup>2</sup>	Stainless Steel
30	44	60	21.5	25	7 x M5	4	1.7	SSD-30
36	52	72	23.5	27.5	5 x M6	12	3.9	SSD-36
44	61	80	25.5	29.5	7 x M6	12	6.4	SSD-44
50	70	90	27.5	31.5	8 x M6	12	11.2	SSD-50
55	75	100	30.5	34.5	8 x M6	12	18.3	SSD-55
62	86	110	30.5	34.5	10 x M6	12	26.5	SSD-62
68	86	115	30.5	34.5	10 x M6	12	30.9	SSD-68
80	100	145	32.5	38	7 x M8	30	86.8	SSD-80
110	145	185	50	57	9 x M10	59	349.6	SSD-110
125	160	215	54	61	12 x M10	59	672.4	SSD-125

(1) 10.9 Class, DIN 931      (2) Tightening Torque

Diameter	Tolerance
≤ 30	H6 / j6
> 30 ~ 50	H6 / h6
> 50 ~ 80	H6 / g6

# Accessory

## Pin Gauge

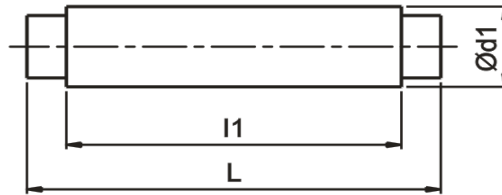

$M_n$	$d_l$	$l_l$	$L$	Order Code
1	2	-	20	B020
1.5 / 1.75 / 1.591 (Pitch 5)	3	16	20	B030
2	4.2	20	28	B042
2.5 / 3	5	25	33	B050
4 / 3.183 (Pitch 10) / 4.244 (Pitch 13.33)	7	30	40	B070
4.5 / 5	9	34	42	B090
6	10	35	43	B100
8	14	35	45	B140
10	18	35	42	B180
12	20	43	50	B200

## Position Pin



$M_n$	$d_6$	$d_2$	$t_1$	$L$	Order Code
1 / 1.5 ( $B \leq 17$ )	6	M4	6	24	PIN-06-L024
1.5 / 1.75	6	M4	6	28	PIN-06-L028
2	6	M4	6	30	PIN-06-L030
2	8	M5	8	30	PIN-08-L030
2.5 / 3 / 3.183 (Pitch 10)	8	M5	8	40	PIN-08-L040
3	12	M6	12	45	PIN-12-L045
4	8	M5	8	50	PIN-08-L050
4	12	M6	12	55	PIN-12-L055
4	16	M8	16	60	PIN-16-L060
4.5 / 5	12	M6	12	70	PIN-12-L070
5	16	M8	16	70	PIN-16-L070
6	16	M8	16	80	PIN-16-L080
6	20	M10	18	80	PIN-20-L080
8	20	M10	18	100	PIN-20-L100
10	20	M10	18	120	PIN-20-L120
12	20	M10	18	140	PIN-20-L140

# Rack Gauge for Installation

## Rack Gauge for Installation

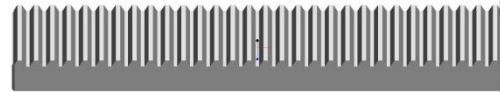
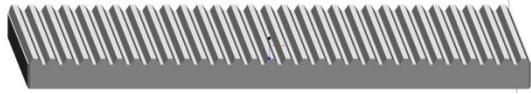

Helical Teeth

Straight Teeth

Mn	Teeth	L	Teeth No.	Order Code
1	Helical	150	45	RGH01
	Straight	141.37	45	RGS01
1.5	Helical	150	30	RGH1J
	Straight	141.37	30	RGS1J
2	Helical	200	30	RGH02
	Straight	188.49	30	RGS02
2.5	Helical	200	24	RGH2J
3	Helical	200	20	RGH03
	Straight	188.49	20	RGS03
4	Helical	200	15	RGH04
	Straight	188.49	15	RGS04
5	Helical	200	12	RGH05
	Straight	251.32	16	RGS05
6	Helical	200	10	RGH06
	Straight	245.04	13	RGS06
8	Helical	213.33	8	RGH08
	Straight	251.32	10	RGS08
10	Helical	233.3	7	RGH10
	Straight	219.91	7	RGS10
12	Helical	280	7	RGH12
	Straight	263.89	7	RGS12
1.591 (Pitch 5)	Straight	150	30	RGS1K
3.183 (Pitch 10)	Straight	200	20	RGS3B
4.244 (Pitch 13.33)	Straight	213.33	15	RGS4D

## Rack Size according to DIN 867

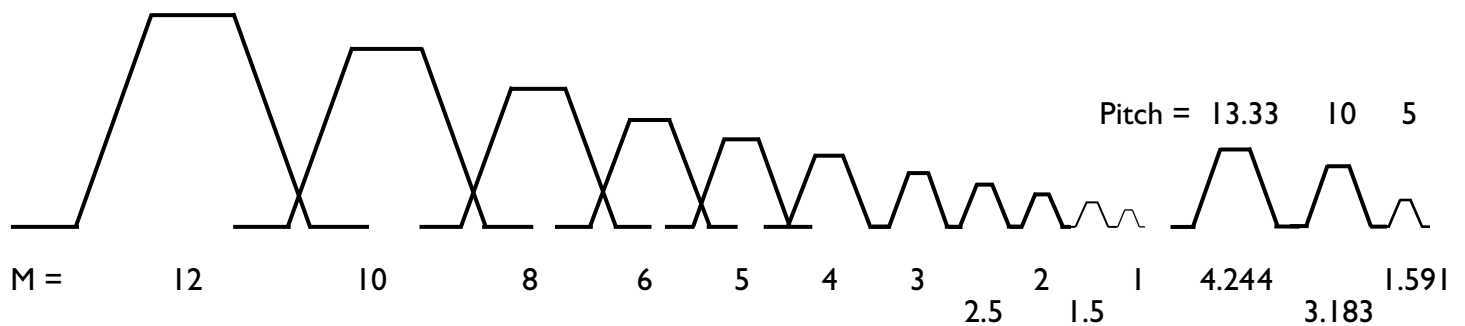

# Rack Calculation and Selection

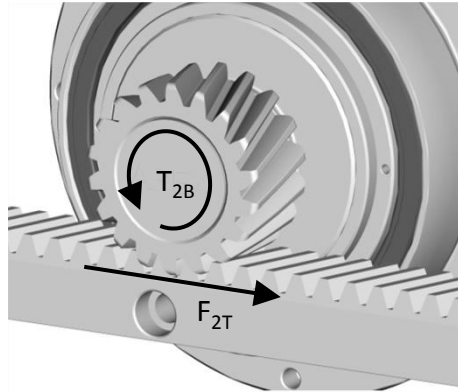

$$F_{2T} = 2 \times T_{2B} / d$$

d : Pitch Circle Diameter

Application		Horizontal handling	Vertical lifting
Unit		Application parameters	
Total load weight	M	Kg	Kg
Speed	V	m/s	m/s
Acceleration time	ta	s	s
Gravitational acceleration	g	9.8 m/s <sup>2</sup>	9.8 m/s <sup>2</sup>
Friction coefficient	μ	-	-
Pitch circle diameter of pinion	d	mm	mm
Other additional forces	F	N	N
Safety factor	S <sub>B</sub> <sup>(1)</sup>	-	-
Computational formulas			
		$\alpha = V / ta$ (m/s <sup>2</sup> )	$\alpha = V / ta$ (m/s <sup>2</sup> )
Tangential force of rack	F <sub>N</sub>	$F_N = M \times g \times \mu + M \times a + F$ (N)	$F_N = M \times g + M \times a + F$ (N)
Torque	T <sub>N</sub>	$T_N = (F_N \times d) / 2000$ (Nm)	$T_N = (F_N \times d) / 2000$ (Nm)
Design demand torque	T <sub>NV</sub>	$T_{NV} = T_N \times S_B$ (Nm)	$T_{NV} = T_N \times S_B$ (Nm)
Max. Speed of pinion	N <sub>V</sub>	$N_V = (V \times 19100) / d$ (rpm)	$N_V = (V \times 19100) / d$ (rpm)

(1) Please consider the safety factor according to your experience and application, the general recommended range of 1 to 4 (S<sub>B</sub> = 1 to 4).

Select a suitable pinion.

Calculate the design demand torque (T<sub>NV</sub>)

To choose T<sub>2B</sub> (> T<sub>NV</sub>) according to the table “the max. permitted torque and feed-force of pinion”.

To select the appropriate gearbox and speed ratio to fit the torque.

Refer to APEX Dynamax for a more detailed calculation.

# APEX DYNAMICS, INC.

No.10, Keyuan 3rd Road, Situn District, 40763 Taichung City , TAIWAN

Tel : +886-4-24650219 Web : [www.apexdyna.com](http://www.apexdyna.com) Email : [sales@apexdyna.com](mailto:sales@apexdyna.com)

2017.03.17



**APEX TAIWAN NORTH  
ANDTEK AUTOMATION CO.,LTD**  
TEL +886-02-82262655  
13F-5, No.2, Jian 8th Rd., Jhonghe Dist., New  
Taipei City 235, TAIWAN  
[sales@andtek.com.tw](mailto:sales@andtek.com.tw)  
[www.apexdyna.com](http://www.apexdyna.com)



**APEX TAIWAN CENTRAL  
ANDTEK AUTOMATION CO.,LTD**  
TEL +886-04-23594286  
9F-6, No.925, Sec.4, Taiwan Blvd., Xitun Dist.  
Taichung City 407 TAIWAN  
[sales@andtek.com.tw](mailto:sales@andtek.com.tw)  
[www.apexdyna.com](http://www.apexdyna.com)



**APEX TAIWAN SOUTH  
MEN JENN ELECTRIC CO., LTD.**  
TEL +886-06-2337332 ~ 6  
No.774, Zhonghua Rd., Yongkang Dist., Tainan  
City 710, TAIWAN  
[menjenn@ms24.hinet.net](mailto:menjenn@ms24.hinet.net)  
[www.apexdyna.com](http://www.apexdyna.com)



**APEX DYNAMICS INC. SHANGHAI**  
TEL +86-21-69220577  
No.128 ZHUYING Road QINGPU Industry Area,  
Shanghai, CHINA  
[sales@apexdyna.cn](mailto:sales@apexdyna.cn)  
[www.apexdyna.cn](http://www.apexdyna.cn)

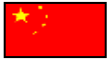

**APEX DYNAMICS SHENZHEN, LTD.**  
TEL +86-755-84516325  
No. 1102A of D area , CFG mansion ,Bao Yuan  
Road , Bao' an District , Shenzhen ,CHINA.  
[sales@szapexdyna.com](mailto:sales@szapexdyna.com)  
[www.szapexdyna.com](http://www.szapexdyna.com)

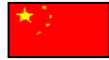

**APEX DYNAMICS BEIJING, LTD.**  
TEL +86-10-69570691  
NO.1,YaoPingRoad,SongZhuang Town, Tongzhou  
istrict, Beijing, CHINA.  
[bjapexdyna@163.com](mailto:bjapexdyna@163.com)  
[www.bjapex.cn](http://www.bjapex.cn)

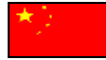

**CHONGQING APEX DYNAMICS CO., LTD.**  
TEL +86-23-67686860  
406, Building 5, No.68,Jinyu Avenue, Beibu New  
Area, Chongqing, CHINA  
[sales@cqapexdyna.com](mailto:sales@cqapexdyna.com)  
[www.apexdyna.com](http://www.apexdyna.com)

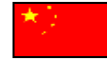

**APEX (XIAMEN) DYNAMICS TECHNOLOGY CO.,  
LTD.**  
TEL +86-0592-720-5279  
Unit B-3,1F.,No.129,Jingquan Road, Jimei District,  
Xiamen, Fujian, CHINA  
[sales@xmapexdyna.com](mailto:sales@xmapexdyna.com)  
[www.xmapexdyna.com](http://www.xmapexdyna.com)



**APEX DYNAMICS USA, INC.**  
TEL +1-631-2449040  
885 Marconi Avenue Ronkonkoma, NY 11779  
U.S.A.  
[sales@apexdynamicsusa.com](mailto:sales@apexdynamicsusa.com)  
[www.apexdynamicsusa.com](http://www.apexdynamicsusa.com)



**APEX DYNAMICS KOREA**  
TEL +82-31-8179992  
1246-32, Seongsuk-dong, Ilsandong-gu, Goyang-  
city, Gyeonggi-Do, KOREA (R.O.K) 410-570  
[sales@apexdynakorea.co.kr](mailto:sales@apexdynakorea.co.kr)  
[www.apexdynakorea.co.kr](http://www.apexdynakorea.co.kr)



**APEX DYNAMICS JAPAN**  
TEL +81-092-4511202  
1-13-3, Sannou, Hakata-ku, Fukuoka-Shi 812-  
0015, JAPAN  
[sales@apexdyna.jp](mailto:sales@apexdyna.jp)  
[www.apexdyna.jp](http://www.apexdyna.jp)



**APEX DYNAMICS SINGAPORE PTE LTD**  
TEL +65-62-626228  
3 South Buona Vista Road, #05-15 & #06-15.  
SINGAPORE 118136  
[sales@apexdyna.com.sg](mailto:sales@apexdyna.com.sg)  
[www.apexdyna.com.sg](http://www.apexdyna.com.sg)



**APEX DYNAMICS (THAILAND) CO., LTD.**  
TEL +66-2-3266233  
73 Soi Ladkrabang 30, Kadkrabang Rd.,Bangkok  
10520, THAILAND  
[sales@apexdyna.co.th](mailto:sales@apexdyna.co.th)  
[www.apexdyna.co.th](http://www.apexdyna.co.th)



**APEX DYNAMICS BV**  
TEL +31-492-509995  
Churchillaan 101 5705 BK Helmond,  
NETHERLANDS  
[sales@apexdyna.nl](mailto:sales@apexdyna.nl)  
[www.apexdyna.nl](http://www.apexdyna.nl)  
[www.apexdyna.be](http://www.apexdyna.be)



**APEX DYNAMICS  
POLSKA SP. Z O.O.**  
TEL +48-12-6304728  
Krakowska 50, 32-083 Balice, POLAND  
[sales@apexdyna.pl](mailto:sales@apexdyna.pl)  
[www.apexdyna.pl](http://www.apexdyna.pl)



**APEX DYNAMICS SPAIN, S.L**  
TEL +34-93-6562990  
Poligono Industrial Molí dels Frares, Calle C nº  
12,08620 - Sant Vicenç dels Horts, Barcelona,  
SPAIN  
[apexdyna@apexdyna.es](mailto:apexdyna@apexdyna.es)  
[www.apexdyna.es](http://www.apexdyna.es)



**APEX DYNAMICS IRAN.**  
TEL +98-21-66593517  
APT#6, 3rd Flr, No.5, 3rd Kowsar St., Sattarkhan  
Ave., Tehran, IRAN  
[alahyari@farasysco.com](mailto:alahyari@farasysco.com)  
[www.apexdyna.ir](http://www.apexdyna.ir)



**APEKS REDUKTOR VE DISLI SAN. TIC. LTD. STI.**  
TEL +90-232-4589960  
10042 Sok.No:10 AOSB Çiğli-İzmir, TURKEY  
[sales@apexdyna.com.tr](mailto:sales@apexdyna.com.tr)  
[www.apexdyna.com.tr](http://www.apexdyna.com.tr)



**APEX DYNAMICS AUSTRALIA PTY LTD.**  
TEL +613-95-852739  
36 Taunton Drive, Cheltenham, Victoria 3192  
AUSTRALIA.  
[sales@apexdyna.com.au](mailto:sales@apexdyna.com.au)  
[www.apexdyna.com.au](http://www.apexdyna.com.au)



**APEX DYNAMICS (I) JV**  
TEL +91-80-55345541  
GAT NO. 279, KHED SHIVAPUR BAUG, TALUKA  
HAVELI PUNE- 412205 INDIA.  
[sales@apexdyna.co.in](mailto:sales@apexdyna.co.in)  
[www.apexdyna.co.in](http://www.apexdyna.co.in)



**APEX DYNAMICS FRANCE SAS**  
TEL +33-160-135097  
11 - Burospace F - 91570 -  
Bièvres, FRANCE  
[info@apexdyna.fr](mailto:info@apexdyna.fr)  
[www.apexdyna.fr](http://www.apexdyna.fr)



**APEX DYNAMICS SWEDEN AB**  
TEL +46-75-2424444  
Fredrikbergsgatan 2 SE-573 92 Tranås, SWEDEN  
[sales@apexdyna.se](mailto:sales@apexdyna.se)  
[www.apexdyna.se](http://www.apexdyna.se)



**PT.APEX DYNAMICS INDONESIA**  
TEL +62 21 2928 3681  
Rukan Aralia Blok HY43 no.11, Harapan Indah II,  
Bekasi - Jawa Barat, INDONESIA 17214  
[sales@apexdyna.co.id](mailto:sales@apexdyna.co.id)  
[www.apexdyna.co.id](http://www.apexdyna.co.id)



**APEX DYNAMICS GERMANY GMBH**  
TEL +49-7181-9329955  
Spanninger Str. 9, 73650 Winterbach, GERMANY  
[Langer@apexdynamics.de](mailto:Langer@apexdynamics.de)  
[www.apexdynamics.de](http://www.apexdynamics.de)



**APEX DYNAMICS CZECH S.R.O.**  
TEL +420-577-663877  
tř. Tomáše Bati 1851 765 02 Otrokovice ČESKÁ  
REPUBLIKA  
[info@apexdynaczech.cz](mailto:info@apexdynaczech.cz)  
[www.apexdynaczech.cz](http://www.apexdynaczech.cz)



**APEX DYNAMICS РОССИЯ**  
TEL +7-495-2255452  
+7-495-6462422  
г.Москва, ул. Южнопортовая, дом 7, строение  
“С”, 3-й этаж  
[info@apexdynarussia.ru](mailto:info@apexdynarussia.ru)  
[www.apexdynarussia.ru](http://www.apexdynarussia.ru)



**APEX DYNAMICS UK LIMITED**  
TEL +44-1827-253340  
2 Centurion Way, Centurion Park, Tamworth  
Staffs, B77 5PN, UK  
[sales@apexdynamicsuk.com](mailto:sales@apexdynamicsuk.com)  
[www.apexdynamicsuk.com](http://www.apexdynamicsuk.com)



**APEX DYNAMICS SWITZERLAND AG**  
TEL +41-55-4517020 Talstrasse 24, CH-8852  
Altendorf, SWITZERLAND  
[info@apexdyna.ch](mailto:info@apexdyna.ch)  
[www.apexdyna.ch](http://www.apexdyna.ch)



**APEX DYNAMICS MOTION SDN BHD** TEL +60  
7237 1055  
No.1, Jalan Perniagaan Setia 3, Taman  
Perniagaan Setia, 81100 Johor Bahru, Johor,  
MALAYSIA (Setia Business Park 2 @ Iskandar  
Malaysia)  
[sales@apexdyna.com.sg](mailto:sales@apexdyna.com.sg)  
[www.apexdyna.com.sg](http://www.apexdyna.com.sg)



**APEX DYNAMICS BRAZIL**  
TEL +55-47-30298700  
Rua Senador Petrônio Portela, 47 - Bloco 5, Zona  
Industrial Norte - CEP 89218-575 - Joinville (SC)  
[lucan@neoyama.com.br](mailto:lucan@neoyama.com.br)  
[adriano.duarte@neoyama.com.br](mailto:adriano.duarte@neoyama.com.br)  
[www.neoyama.com.br](http://www.neoyama.com.br)



**APEX DYNAMICS ITALY**  
TEL +39 02.36634521  
VIA E. DE AMICIS, 2 – 20091 BRESSO (MI)  
[info@apexdynamics.it](mailto:info@apexdynamics.it)  
[www.apexdynamics.it](http://www.apexdynamics.it)